



CONWAY, SC



HISTORIC DESIGN REVIEW DISTRICTS: COMMUNITY APPEARANCE GUIDELINES



DOWNTOWN,



SIGNS,

MAIN STREET CORRIDOR,



VOLUNTARY RESIDENTIAL,



& THE WACCAMAW RIVERFRONT DISTRICT



Adopted December 12, 2011



Thank you for being a steward of the historic fabric of Conway's neighborhoods and commercial districts, we hope you find this document inspiring.

These guidelines constitute accepted suggestions for the preservation of the character of Conway's historic resources. They were written in order to retain a level of national historic significance and guide property owners in the choices they make for completing sensitive work on their structures, applying for historic preservation tax incentives and making it easier for the community to apply for future historic preservation-based grants. This document is based on the most current standards for the treatment of historic property and environments, as set by the Secretary of the Interior, National Park Service and is to be used as guiding principal for the care and review of these resources, by those in Conway, South Carolina. The City of Conway, Conway Community Appearance Board, the National Park Service, the South Carolina State Historic Preservation Office, jB+a Community Advantage, LLC., or any person's affiliated with the creation of these guidelines shall not be held liable for any damage or unacceptable results upon a property in conjunction with the application of these guidelines.

This publication has been financed in part with federal funds from the National Park Service, U.S. Department of the Interior, and Preserve America funds through the South Carolina State Historic Preservation Office (Department of Archives and History (SCDAH)). However, the contents and opinions do not necessarily reflect the views or policies of the Department of the Interior or SCDAH, nor does the mention of trade names, commercial products, example photo locations or consultants constitute endorsement or recommendation by these agencies. This program received Federal financial assistance for identification and protection of historic properties. Under Title VI of the Civil Rights Act of 1964, Section 504 of the Rehabilitation Act of 1973, and the Age Discrimination Act of 1975, as amended, the U.S. Department of the Interior prohibits discrimination on the basis of race, color, national origin, age, gender or disability in its federally-assisted programs. If you believe you have been discriminated against in any program, activity, or facility as described above, or if you desire further information, please write to: Office of Equal Opportunity, National Parks Service, 1840 C Street, N.W., Washington, D.C. 20240.

INCLUDES INTRODUCTION AND APPENDIX WITH:

- Glossary
- *Secretary of the Interior's Standards for Rehabilitation*
- Conway Historic Preservation Ordinance
- CAB Application & COA Submittal Checklist & Forms
- CAB Rules for Procedure & Applicant Flowchart
- Financial Incentives for Historic Preservation
- Additional Resources for Assistance

Prepared For:

- Conway Community Appearance Board
- City of Conway, SC
- Conway Downtown Alive

Designed and Authored By:
Paul Simo, Heritage Preservation Planner



jB+a Community Advantage, LLC
700 Galleria Parkway, Ste. 400
Atlanta, Georgia 30339
www.jbaAdvantage.com

(In coordination with Robert & Company, Atlanta (planning & authors of the 2011 *Conway Unified Development Ordinance*), the 2009-11 City of Conway Planning Department, 2010-11 Conway Community Appearance Board, public participants and residents.)

ORDINANCE #2011-12-12(B)

**AN ORDINANCE TO ADOPT THE
"HISTORIC DESIGN REVIEW DISTRICTS: COMMUNITY APPEARANCE GUIDELINES"**

WHEREAS, Title 6, Chapter 29 of the Code of Laws of South Carolina 1976, as Amended known as the "South Carolina Local Government Comprehensive Planning Enabling Act of 1994" empowers municipalities to create a board of architectural review or similar body by specific provisions in the local zoning ordinance.

WHEREAS, the City Council of the City Of Conway, South Carolina deems it necessary, for the general purposes of guiding historic design review development in accordance with existing and future needs and promoting the public health, safety, morals, convenience, order, appearance, prosperity, and general welfare to enact such an ordinance; and

WHEREAS, the City Council, pursuant to the provisions of the Title 6, Chapter 29 of the Code of Laws of South Carolina 1976, as Amended has appointed the Community Appearance Board to recommend the boundaries of the various original historic design review districts and appropriate regulations to be enforced herein; and

WHEREAS, the Community Appearance Board has divided the City of Conway, South Carolina into historic design review districts and has prepared regulations pertaining to such districts in accordance with Secretary of Interior Standards for Rehabilitation and the South Carolina Department of Archives and History (SCDAH); and

WHEREAS, the City Council, upon recommendation from the Community Appearance Board, has given the due public notice of hearing related to historic design review districts, regulations, and restrictions and held such public hearings; and

WHEREAS, all requirements of Title 6, Chapter 29 of the Code of Laws of South Carolina 1976, as Amended regarding the preparation and adoption of a new "Historic Design Review Districts: Community Appearance Guidelines"

NOW, THEREFORE, BE IT ORDAINED by the City Council of the City of Conway, in Council duly assembled that this Ordinance to adopt the "Historic Design Review Districts: Community Appearance Guidelines" in accordance with Title 6, Chapter 29 of the Code of Laws of South Carolina 1976, as Amended known as the "South Carolina Local Government Comprehensive Planning Enabling Act of 1994."

BE IT FURTHER ORDAINED, that all ordinances or parts of ordinances inconsistent with this Ordinance are hereby repealed to the extent of such inconsistency.

First Reading: Nov. 14, 2011 Second Reading: Dec. 12, 2011



Ordinance Done & Ratified by City Council:

December 12, 2011

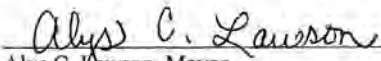
Alys C. Lawson, Mayor

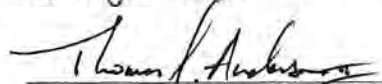
Thomas J. Anderson II, Mayor Pro-Tem

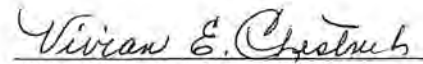
Vivian E. Chestnut, Council Member

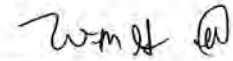
William M. Goldfinch IV, Council Member

Irby L. Koon, Council Member

Jean M. Timbes, Council Member

Larry A. White, Council Member

ATTEST: Vicky Lefler, City Clerk

SECTION A

OVERVIEW

page:

CHAPTER 1. INTRODUCTION

1.1. Why Have Community Appearance Guidelines? A.1

- What Guidelines DO
- What Guidelines DO NOT DO

1.2. Benefits of Local "Historic Design Review Districts" A.2

1.3. The Conway Community Appearance Board (CAB) A.3

1.4. **Conway Historic District(s) Information** A.4

- The Significance of National Register Historic Districts
- Guideline's Relationship to Zoning
- **Conway's Design Review Districts Map** A.5

1.5. Required and Voluntary CAB Design Review A.6

- Which Properties Require Design Review?
- Benefits of Voluntary Design Review

1.6. Retaining a "Sense of Place" & Context. A.8

1.7. Recognize Change A.9

CHAPTER 2. HOW TO USE THESE GUIDELINES

2.1. Project Planning and Preservation Principles A.10

- Levels of Preservation Effort
- The Secretary of the Interior's Standards A.11

2.2. **Certificate of Appropriateness CAB Approval Matrix** A.12

2.3. **How to Apply for a Certificate of Appropriateness (COA)** . A.17

2.4. Design Review Process Flowchart. A.18

SECTION B

COMMERCIAL HISTORIC DESIGN REVIEW DISTRICT GUIDELINES

Intro. Conway's Historic Downtown Overview B.1

CHAPTER 3. BASICS OF TRADITIONAL COMMERCIAL BUILDINGS

3.1. Commercial Forms vs. Applied Styles B.2

3.2. Commercial Building Forms B.3

- One-Part Commercial
- Two-Part Commercial
- The "Business Block"
- Other Forms of Commercial Buildings

3.3. Parts of the Commercial Façade B.4

- The Storefront
- The Upper Façade B.5
- The Building Cornice

GUIDELINES TABLE OF CONTENTS

(Section B, Chapter 3 Continued:)

page:

3.4. The Downtown Environment B.6

- Density
- Setback
- Building Height B.7
- "Horizontal Continuity" B.8
- The Sidewalk is the "Pedestrian Hallway"

CHAPTER 4. COMMERCIAL REHABILITATION & ARCHITECTURAL DESIGN GUIDELINES

4.1. Storefronts B.9

- General Standards
- Entrances and Plans B.10
- Doors
- Displays B.11
- Transom Windows B.12
- Bulkheads B.13
- Store Cornices / Belt Courses / Sign Band B.14

4.2. Upper Façades B.15

- Upper Windows
- Upper Building Cornices B.16
- Commercial Roofs B.17

 - 1. Roofing Materials
 - 2. Parapet Walls

4.3. Rear "Façades" B.18

- Retain Context of the Rear Elevation
- Rear Utilities B.19
- Back Entrances & Loading Areas

4.4. Additional Features and Amenities B.20

- Exterior Walls
- Quality Architectural Materials B.21
- Awnings and Canopies B.22

4.5. **New Commercial Construction** B.24

- Placement and Orientation
- Scale
- Style

4.6. **New Commercial Additions** B.25

- Keep Additions in Context
- Rooftop Additions
- Adding Balconies B.26
- Adding Porches, Stairs & Patios

GUIDELINES TABLE OF CONTENTS

SECTION C

page:

TRADITIONAL COMMERCIAL SIGN GUIDELINES

CHAPTER 5. INTRODUCTION TO SIGN BASICS

- 5.1. Marketing and Sign Basics C.1
 - “Keep it Simple”
 - The Context of Signs C.2
 - Use Appropriate Scale
 - Follow Good Sign Placement C.3
 - Create a “Hierarchy” of Sign Types
- 5.2. Sign Materials. C.4
- 5.3. Sign and Architectural Lighting C.5
 - True NEON vs. “Neon Appearing” Signs
- 5.4. Tips for Arranging Facade Signage C.7
- 5.5. Traditional Sign Categories C.7

CHAPTER 6. DOWNTOWN COMMERCIAL SIGN GUIDELINES

- 6.1. The Primary Sign C.8
 - Suggested Primary Sign Types C.9
- 6.2. Secondary Sign(s) C.10
- 6.3. Subordinate Signs(s) C.11
- 6.4. “Grandfathered” & Historic Identification Signs C.12
- 6.5. Advertising and Other Signs C.14
 - Product Endorsement Signs
 - Temporary Sales Signs and Banners
 - Pedestrian Zone Advertising (“Sandwich Boards”)
 - Historic, Directory and Address Signs

SECTION D

MAIN STREET CORRIDOR HISTORIC DESIGN REVIEW DISTRICT & (VOLUNTARY) RESIDENTIAL GUIDELINES

- Intro. Conway’s Main St. Corridor Architecture & Environment**
- Professional/Commercial Infill Along Main Street D.1
 - Conway’s Traditional Residential Overview D.2

CHAPTER 7. BASICS OF TRADITIONAL RESIDENTIAL BUILDINGS

- 7.1. Residential Form vs. Style D.3

(Section D, Chapter 7 Continued:)

page:

- 7.2. Common Historic Residential Building Forms D.4
 - Basic “Shotgun” & “I-House” Forms D.4
 - Basic Gable-end & Pyramid Cottage Forms D.4
 - Progression of Gable-end House Forms D.5
 - Progression of Pyramid House Forms D.5
 - Georgian, “Raised Cottage” & House Forms D.6
 - Multiple Bungalow Forms. D.6
 - Post-WWII “American Small House” & Ranch D.7
 - 20th-21st Century Professional/Residential D.7

CHAPTER 8. RESIDENTIAL RESTORATION & ARCHITECTURAL DESIGN GUIDELINES

- 8.1. Residential Openings and Amenities D.8
 - Residential Entrances & Doors
 - Residential Windows & Fenestration D.9
 - Residential Lighting D.10
- 8.2. Foundations, Piers and Crawlspace D.10
 - Architectural Materials
- 8.3. Porches D.11
 - Construction, Enclosures & Connection
 - Columns & Millwork D.12
 - Coverings, Eaves & Porch Roofs
- 8.4. Exterior Walls and Insulation D.13
 - Siding, Clapboard & Gables
 - Masonry Walls & Applied Coatings. D.14
- 8.5. Roofs and Rooflines D.15
 - Shingles & Covering
 - Roof Pitch
 - Chimneys, Eaves & Parapets
- 8.6. Residential Yards D.16
 - Landscape Features & Surfaces (& Parking)
 - Fences, Steps, Retaining Walls & ADA Ramps
- 8.7. **Commercial Adaptive-Use & Sign Placement** D.17
- 8.8. **New Residential Construction** D.18
 - Compatible Placement, Construction & Materials
 - Matching Scale and Form
 - Use Contextual Style
- 8.9. **New Residential Additions** D.19
 - Views from the Public Right-of-way
 - Home Additions in Context
 - Residential Rooftop Additions

GUIDELINES TABLE OF CONTENTS

SECTION

E

page:

WACCAMAW RIVERFRONT HISTORIC DESIGN REVIEW DISTRICT GUIDELINES

Intro. Waccamaw Riverfront District (WRD) Overview E.1

CHAPTER 9. BASICS OF THE HISTORIC RIVERFRONT ENVIRONMENT

- 9.1. Character Areas of Conway's Riverfront E.2
 - A) "River-side of the Railroad"
 - B) "Town-side of the Railroad"
- 9.2. Common Historic Warehouse & Storage Building Forms. . E.3
 - Gable-end Shed and Pole Storage Barns
 - Heavy Timber Post & Beam
 - "Fireproof," Masonry, or "Mill Construction"
- 9.3. Waccamaw Riverfront Development Standards E.4
 - Preservation of Viewsheds
 - Public Amenities & the Boardwalk/Riverwalk
 - Infill, Parking & Multiple Structures Per Lot E.5
 - Setback from Curb Along Streets & Sidewalks
 - Riverfront Buffer Areas: Recreation & Nature E.6

CHAPTER 10. WACCAMAW RIVERFRONT REHABILITATION & ARCHITECTURAL DESIGN GUIDELINES

- 10.1. Riverfront Building Preservation E.7
 - General Standards & Features
- 10.2. Riverfront Warehouse Openings E.8
 - Entrances, Doors & Loading Doors
 - Windows & Fenestration E.9
- 10.3. WRD Foundations, Piers and Crawlspace E.10
- 10.4. WRD Buildings' Exterior Cladding E.11
 - Siding & Clapboards (Historic VS. New)
- 10.5. WRD Roofs, Canopies and Roof Lines E.12
 - Columns, Brackets & Eaves (incl. Sheds)
 - Industrial Roofing & Covering E.13
 - Roof Pitch & Curved Roofs
 - Roof Monitors, Vents, Skylights & Chimneys
- 10.6. WRD Public Amenities and Features E.14
 - Landings, Patios & Property Connections (to Boardwalk)
 - Railings & Private Fences Along Riverwalk
 - WRD Sign Standards & Area Lighting E.15
 - Trash, Dumpsters & WRD Public Furniture

SECTION

F

page:

DEMOLITION, RELOCATION AND STABILIZATION

CHAPTER 11. PROCESS OF CARING FOR BUILDINGS

- 11.1. Failure to Provide "Ordinary Maintenance" F.1
- 11.2. Variances for Undue Hardship F.2
- 11.3. Criteria for Relocation F.2
- 11.4. Criteria for Demolition F.3
- 11.5. Stabilization ("Mothballing") of Structures F.4

REFERENCE AND APPENDICES

R

APPENDIX I. – Glossary of Terms REF.1

APPENDIX II. – Conway Unified Development Ordinance Items:

- Community Appearance Board (Articles 14.1.1 & 14.1.2) REF.5
- Historic Design Review and
Community Appearance Requirements (Article 14.1.3) . . . REF.8
- Site and Plan Submittals (Articles 14.1.3 & 14.1.4) . . . REF.9
- Design Review Procedures for Applicants
and Application Process (Article 14.1.5(A-D.1) REF.9

APPENDIX III. - FORMS:

- Conway Certificate of Appropriateness: Application REF.10
- CAB Requirements for submissions REF.11
- CBD Incentive Program & Application REF.13
- Temporary Business Event Sign Permit: Application REF.14
- Conway Street Tree Requirements (COA Application) REF.15

APPENDIX IV. – Routine Maintenance Resources

- 1. Eight Steps to Complete a Preservation Project REF.16
- 2. National Park Service Preservation Briefs REF.18
- 3. Getting Energy Efficiency from Older Buildings REF.19

APPENDIX V. – Financial Incentives for Preservation Work

- 1. Federal Historic Rehabilitation Income Tax Credits REF.23
- 2. South Carolina State Historic Rehab Income Tax Credits . . . REF.24
- 3. Horry County Tax Incentive & Historic District Benefits REF.25
- 4. Conway Property Tax Abatement & Local Incentives REF.27

APPENDIX VI. - Hints for a Successful Historic District Business. REF.28

APPENDIX VII. – Additional Resources for Assistance REF.29



SECTION A

OVERVIEW

Chapter 1:
Introduction

Chapter 2:
How to Use These Guidelines

1.1. Why Have Community Appearance Guidelines?

Design guidelines are an important part of the City of Conway's efforts to recognize and protect its historic downtown and neighborhoods. **These guidelines are used by the City of Conway, Community Appearance Board (CAB) in the design review process for proposed exterior changes in appearance and/or new construction in a local "Historic Design Review District" (HDRD).** They help determine whether the proposed change is compatible with the historic structures and character of the district. Upon finding that a proposal would not adversely affect the district or the architectural significance of an individual historic resource, a Certificate of Appropriateness (COA) is issued by the CAB. The COA is given to the building owner to commence work or apply for a zoning permit with the City, and/or if the proposed work requires a building permit.

Conway's residents enjoy the advantage of increased economic value and a built environment protected from unsympathetic changes. By preserving and maintaining visual character, the CAB ensures that future generations will enjoy the benefits of Conway's rich architectural heritage.

To accomplish this, the CAB shall exercise the following guidelines in reviewing proposed structures, site improvements, signs and landscaping, in addition to those standards pertaining to the particular base zoning district in which the development occurs. The application of these design guidelines ensures that uniform, objective standards are used in evaluating proposals for all COAs.

WHAT GUIDELINES DO:

- Respect the traditional commercial character of each of the Design Review Districts individually, reinforcing community identity and appearance.
- Retain the architectural character and historic, quality materials of buildings during the course of maintenance, renovation or rehabilitation.
- Ensure Compatibility of proposed additions to existing buildings and new construction. This includes helping users identify setback, spacing, and scale. These guidelines will help users define characteristics of new construction by noting the existing building traits (such as local or regional construction details, the orientation of structures, mass and scale, window patterns or openings, or materials) within the immediate vicinity of a project site in a particular Historic Design Review District.
- Avoid Demolition-by-Neglect.
- Preserve significant site features, such as landscaping, trees, pedestrian features, a comfortable and inviting-shopping environment, and hierarchy of the pedestrian, riverfront and/or auto-oriented environments.
- Protect property owner investment by suggesting "best practices."

WHAT GUIDELINES DO NOT DO:

- Do not affect the use of your property. The design review process pertains only to a proposed "material change in appearance" to a property and not to a proposed change in use. If change in use is desired please contact the Conway Planning Department.
- Do not regulate the design or alteration of interiors. However, there are suggestions with regard toward built-in elements within display windows, and/or changes to the interior surface treatments that may affect the stability of exterior building materials, such as the treatment of walls).
- Do not tell you what color to paint your property. However, application of paint or sealants on unpainted surfaces (or the type of paint removal process on older or historic materials) is reviewed. Following appropriate suggestions is very important for the health of the building fabric.
- Do not take effect unless property owners have a property within one of the specified local Conway Historic Design Review Districts and propose actions to the exteriors of the property which may require a Building Permit or a Certificate of Appropriateness. (See "Why Have Guidelines" above.)

1.2. Benefits of Local “Historic Design Review Districts”

“In ... smaller towns and cities across the state, local historic district status was a positive factor in determining the value of a house. For example, in Georgetown, houses in the local historic district sold for 11% more than comparable non-district houses, while in Anderson, district houses sold for 36% more.”

- Study by John Kilpatrick - *Historic Districts Are Good for Your Pocketbook: The Impact of Local Historic Districts on Home Prices in South Carolina*, South Carolina Department of Archives & History

Benefits of Local Historic [Design Review] Districts

Information sourced from: *The National Alliance of Preservation Commissions (NAPC) & The National Trust for Historic Preservation*

Local districts protect the investments of owners and residents. Buyers know that the aspects that make a particular area attractive will be protected over a period of time. Real estate agents in many cities use historic district status as a marketing tool to sell properties.

Local districts encourage better design. It has been shown through comparative studies that there is a greater sense of relatedness, more innovative use of materials, and greater public appeal within historic districts than in areas without historic designations.

Local districts help the environment. Historic district revitalization can, and should, be part of a comprehensive environmental policy, thus minimizing the impact on landfills. Adaptation and re-use of existing buildings (made often of irreplaceable, maintainable materials) extends the life of resources and the “latent” energy that was put into their original creation.

The educational benefits of creating local districts are the same as those derived from any historic preservation effort. Districts help explain the development of a place, the source of inspiration, and technological advances. They are a record of ourselves and our communities.

The purpose of establishing the various Historic Design Review Districts are to protect and enhance the contextual aesthetic and visual character of developments within these districts. In particular, the purpose is to encourage and better articulate positive visual experiences along city thoroughfares and to provide for economic growth and stability through the preservation of property values.

(See maps of Conway’s Historic Districts on pages A.5.)

A local district can result in a positive economic impact from tourism. A historic district that is aesthetically cohesive and well promoted can be a community’s most important attraction. The retention of historic areas as a way to attract tourist dollars makes good economic sense.

The protection of local historic districts can enhance business recruitment potential. Companies continually re-locate to communities that offer their workers a higher quality of life, which is greatly enhanced by successful local preservation programs and stable historic districts.

Local districts provide social and psychological benefits. A sense of empowerment and confidence develops when community decisions are made through a structured participatory process rather than behind closed doors or without public comment.

1.3. The Conway Community Appearance Board (CAB)

Notes from the Conway Community Appearance Board

Conway, is a small town located 14 miles inland from the coast as the county-seat to Horry County (pronounced “or-ee”), South Carolina. The traditional downtown and riverfront commercial areas sit on the west bank of the Waccamaw River. Conway is a city that is proud of its history, it’s riverfront heritage and has built a reputation on making southern hospitality a way of life.

The Conway Community Appearance Board (CAB) was established by the City of Conway in 1999 to encourage revitalization of the business district and historic neighborhoods. It strives to protect and enhance local historic and aesthetic attractions to tourists and promote and stimulate business in the downtown area. In 2011 the *City of Conway Unified Development Ordinance* was re-designed from the outdated mid-20th century, strictly use-based, zoning districts city wide to be more form- and character-based. This allows more flexibility in mixing property uses (or vertical mixed use) throughout the city, coordinated through the Planning Dept. that benefits the community as a whole. Article 14 of this ordinance sets the CAB Procedures for specific design review of properties that are located in Conway’s most unique, Historic Design Review Districts (HDRDs) and/or those which opt for voluntary CAB review (see 1.4 “Conway Historic District(s) Information” later in this section). For this level of review these guidelines were needed.

This first edition of the “Historic Design Review Districts: Community Appearance Guidelines” is tailored to meet locally-desired design options in context to the special attributes of the HDRDs, as well as properties applying for voluntary review. They also serve as a comprehensive guide to federal preservation standards. **This guide calls for both an understanding of rehabilitation and contemporary “infill” projects with respect to updated construction techniques and the saving of irreplaceable historic materials.** These pages provide illustrations, annotated photographs and examples, reproducible or downloadable in digital format (available on-line at the City’s website www.cityofconway.com). User-friendly referencing helps both the property owner and the CAB member make unified, cohesive design decisions.

The Conway Community Appearance Board will always strive to educate the public rather than to regulate. Through the distribution of these guide-

*The Conway
Community Appearance Board
will always strive to educate ...
...rather than regulate.*

lines the CAB provides applicants with rehabilitation information and the parameters for orderly growth and development within the local historic districts. Also, “Conway Downtown Alive” and the Conway Downtown Development Authority remain available for additional programs, business information and potentially local funds available for carrying out your work.

Properties and sites found within the boundaries of the Historic Design Review Districts have been identified over the years through local support and represent some of the most important resources that define the character of Conway, South Carolina. Those who own and occupy properties within these districts continue to live and add to the history found here.

We hope that you find these guidelines useful and feel free to contact the CAB or the City with any concerns or questions that you might have.

Sincerely,

*The City of Conway and the Conway Community Appearance Board,
2011.*



Conway, 2009

A OVERVIEW

Chapter 1 INTRODUCTION TO DESIGN GUIDELINES

1.4. Conway Historic District(s) Information

(See Map Figure 1.1) The City of Conway has set up a system of “overlay” districts to help guide what is built. Conway also has National Register Historic Districts and local overlay districts known as “Historic Design Review Districts,” which are based on character and preservation philosophy to retain and maintain irreplaceable historic qualities, sites and properties. Generally, all of the historic districts were identified based on significant dates of development from around 1800 through the 1930s. However there are many properties gaining historic significance each year (per a National Park Service standard “50 Year Rule”). The Conway CAB has an obligation to take in account features or buildings that have the potential for designation as a “contributing historic” property to the character of the surrounding local review districts and for potential future addition to the National Register of Historic Places.

Significance of National Register Historic Districts

The in-town area of Conway comprises multiple overlapping districts established at various times and for different purpose. There are two National Register Historic Districts (NRHD), recognized by the US Department of the Interior, National Park Service (details on file at the South Carolina State Historic Preservation Office (SHPO), part of the *South Carolina Dept. of Archives and History* (SCDAH)). The Downtown NRHD was nominated to the NPS in 1994 and the Conway Residential NRHD in the summer of 2010. National districts are for recognition moreso than local district protection (See “Benefits of Local Historic Design Review Districts (HDRDs)” Pg. A.2).

- The federal *Secretary of the Interior’s Guidelines for the Treatment of Historic Properties* (see pg. A.11) should be considered for all properties in any historic district, but especially by those in NRHDs.

Guideline’s Relationship to Zoning

Design guidelines are an effective tool for protecting the established character of an area by promoting appropriate building forms and style. They cannot, however, regulate the use of buildings within a local or national historic district.



Conway Downtown National Register Historic District

- NOTE: There are sites and places individually listed to the National Register (such as the Burroughs School, the Beaty-Spivey House, churches, the Old Horry Co. Courthouse, the Waccamaw River Memorial Bridge, etc. (visit www.nps.gov/history/nr/research/index.htm for current listings or check with City Planning for the latest listings)).
- ONLY “contributing” properties to the NRHDs can apply for additional historic preservation-based tax benefits for rehabilitation work (see Appendix V - “Financial Incentives for Historic Preservation Projects”).
- **Conway Local Tax Incentive & 15-Year Assessment Freeze:** If your property is located in a NRHD, 50 yrs old or older, or individually listed to the National Register, but not in a local HDRD, you can go for voluntary CAB review of a rehab project following these guidelines for significant, additional local tax benefits. (See Pg. A.6 & Appendix V.3)

The *City of Conway Unified Development Ordinance* delineates permitted land uses for each parcel inside the city limits based on an assigned “zoning district.” Development standards are also prescribed for each zoning district to, at a minimum, regulate the size and placement of a building.

Conway's Design Review Districts Map

Fig. 1.1: Conway Local & National Historic District Boundaries

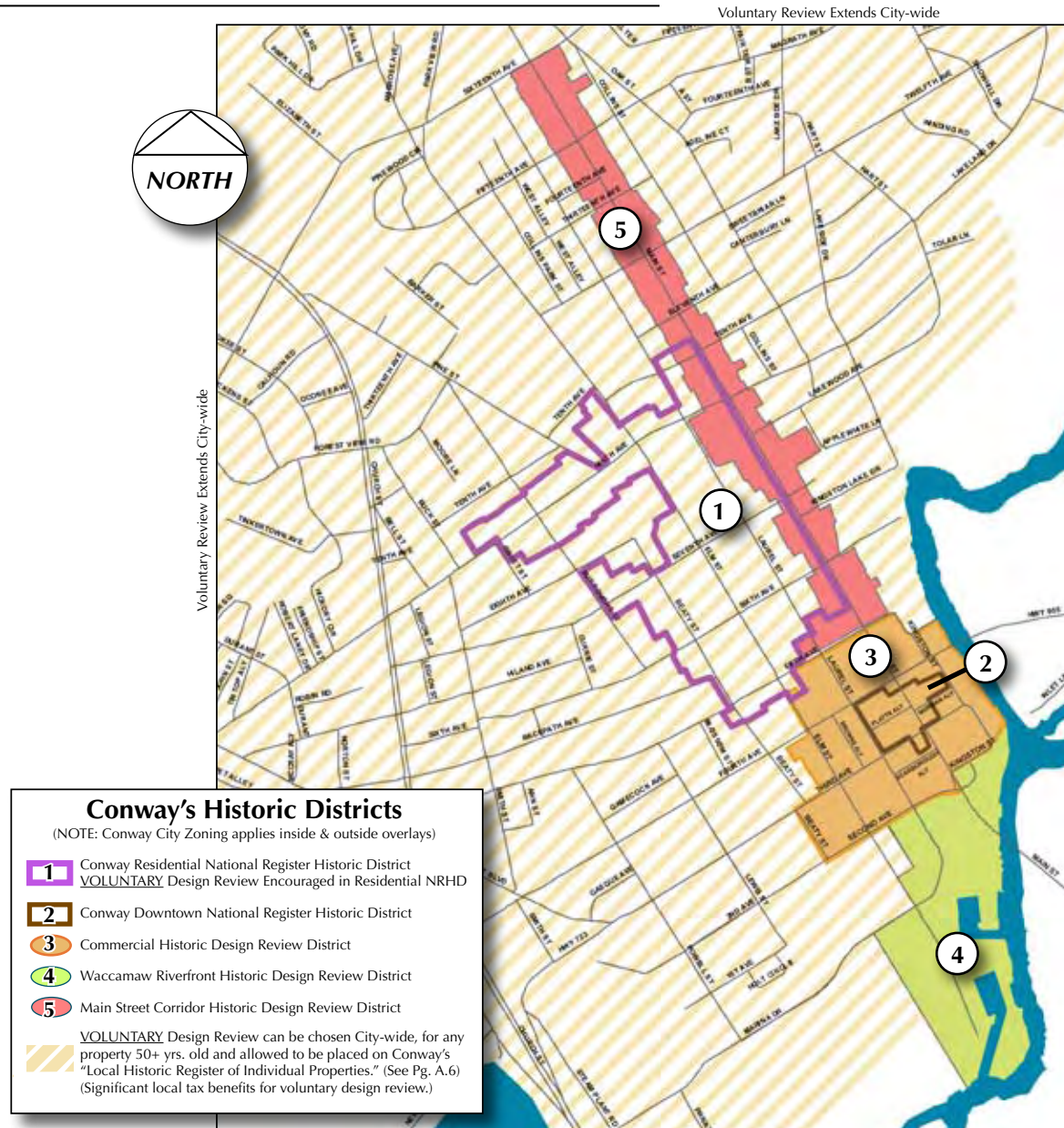

Color classifications represent the local Historic Design Review Districts (HDRDs) that have mandatory design review to which the Conway Community Appearance Board (CAB) reviews building permits on the local level. (Essentially, the whole City is also open for those who desire voluntary review (striped)).

There are also two (2) National Register Historic Districts (outlined boundaries in map to left). Properties that are considered "eligible contributing" properties to these districts might wish to apply for additional federal and state tax benefits for rehab or restoration work (more information on whether your property is eligible can be found through contacting the State Historic Preservation Office at www.scdah.sc.gov, or See Appendixes for more information). In the Conway Residential National Register Historic District, voluntary use of these guidelines with CAB historic design review is greatly encouraged and rewarded with local tax incentives. Note that some areas of overlap of national and local historic districts occurs (see Section A, Chapter 1.4 Conway Historic District Information, Pg A.4).

Historic Design Review Districts may be amended from time to time to include new or separate, non-continuous designated historic districts, to modify existing local historic districts, to designate historic landmarks or for other reasons, provided that such amendment conforms to the provisions of the *City of Conway Preservation Ordinance (Section 14 of the City of Conway UDO)*. Current maps may be obtained from the Conway Planning Department.

A OVERVIEW

Chapter 1 INTRODUCTION TO DESIGN GUIDELINES

1.5. Required and Voluntary Design Review

Which Properties Require Design Review?

ALL properties within any of the designated local Historic Design Review Districts (historic, non-historic, vacant or awaiting new construction) require some form of CAB design review (see map Fig. 1.1 on Pg. A.5). Residential National Register Historic Districts are encouraged to go through voluntary review, see below. All CAB Design Review must occur prior to the standard issue of obtaining permits (see 2.3 "How to Apply for a Certificate of Appropriateness" (COA) later in this Section). **Review will include exterior design considerations using these guidelines.** It makes no difference if the building form is residential, commercial, waterfront or a site/feature.

What is reviewed?

- **All sides of structures are reviewed in the Commercial Historic Design Review District and the Waccamaw Riverfront Historic Design Review District.**
- **Only what is seen from the public right of way is reviewed in residential areas or in the Main Street Corridor Historic Design Review District.**
- ANY demolition, relocation and new construction within local Historic Design Review Districts also requires a COA, and use of these guidelines.

Benefits of Voluntary CAB Design Review

Unique ONLY to Conway: In Conway, SC you do not have to be in a local Historic Design Review District (HDRD) to choose to treat your older properties correctly (following these guidelines), and get rewarded for it! Buildings located anywhere, within the city limits of Conway, SC, and determined by the CAB to have significant historic value, can be placed on a "Local Historic Register of Individual Properties" (*City of Conway Unified Development Ordinance*, Section 14.1.2(B)) and obtain local preservation tax incentives (listed below).

Local, voluntary, review was created for properties located in a National Register District, 50 yrs. old or older, or individually listed to the National Register, but not in a local HDRD to give all owners of significant historic property the ability to tap into additional local tax benefits.

City of Conway Preservation Tax Incentive:

- 15 year Property Tax Assessment Freeze
- Special tax assessment for eligible rehabilitated properties for 15 years equal to the fair market value of the property at the time of preliminary certification

If "voluntary" review is chosen by a property owner:

- Since property owners in National Register Historic Districts or of "eligible" property for Conway's "Local Historic Register of Individual Properties" are highly encouraged to use these guidelines to raise the value of their historic property, local tax incentives are encouraged (see below).
- For any property within a corridor overlay zoning district check with the City of Conway Planning Department for rules and review that apply to the form and Zoning review.
- For any property making major repairs, alterations or changes of use check with the City of Conway Planning Department for rules and review that apply to standard ordinance and Zoning review.

Central Business District Incentive:

- Reimburses Building Permit Fees (if applicable)
- Reimburses Business License Fees for the first two years a new business is in operation

A OVERVIEW

Chapter 1 INTRODUCTION TO DESIGN GUIDELINES

1.6. Retaining a "Sense of Place" & Context

Conway's history is unique. It is represented today by individual structures and groups of buildings contributing to different character areas (see examples below) within the overall commercial center of town. This mix and arrangement of environments creates a distinct "sense of place." Building owners should be mindful of the fact that each structure is an individual expression of its *form* (the shape of the building envelope based on its original function), its *style* (character of the period it was built or significant changes applied from other periods of its history), individual or regional *details* (materials or fenestration applied by its builder or users), and its *environment* (topography, climate, direction the building faces, social conditions, landmark buildings or specific development patterns). The context and history of each area to the whole district becomes a sum of its parts that is uniquely "Conway."

People must see themselves as stewards of historic structures, constructed of materials that will outlast generations. For this, owners are encouraged to retain or repair all original materials and features with guidance by the CAB. Whether a commercial or residential structure, treatment and care for exterior features (windows, doors, walls, specific brick type, etc.) must respect the original intent. If cared for, most historic buildings can be adapted to new technology as long as the nature of the materials is respected and not irreversibly altered. Any item lost, sold for salvage, demolished by neglect, or sent to a landfill is removed from Conway permanently.



Conway, 2009

Central Business District is defined by a pedestrian-environment, on-street parking and closely spaced commercial buildings. Originating in a tight street grid along a central Main Street becoming mid-20th century, auto-oriented north & westward.



Conway, 2009

Waccamaw Riverfront District is as much of a natural conservation district as it is a mostly-pedestrian riverwalk characterized by boardwalks, wood shed-style buildings and landscaped paths. It has some of the oldest structures in Conway.



Conway, 2009

Main Street Corridor is largely comprised of homes, many converted to professional use, with some infill commercial. Forms and styles are 19th- and early-to-mid 20th-century as N. Main St. connects the commercial and residential districts.



Conway, 2009

Government & Civic Sector is a sub-area of the downtown historic commercial environment to the west of the central business district. The street grid corresponds to downtown yet is more auto-oriented to the civic buildings.



Professional/commercial re-use of home, 2009

Downtown National Register Historic Dist., 2009



From residential lawns and moss-covered live oaks and wide city sidewalks, Conway is a traditional riverfront-oriented South Carolina town. The pedestrian environment is comfortable and visually engaging throughout the varied local historic (Design Review) districts.

1.7. Recognize Change

Over time changes are made to most buildings individually. Commercial buildings traditionally have more changes than residential. Changes are also made to the district as a whole with infill and new uses of areas. If any features – even those which have been altered – are of a significant age (generally around 50 years or older) or reflect unique use, local history or styles, it is appropriate to study them and make a determination as to whether they should be retained. This allows the district to be flexible in terms of the marketplace. Some building parts, such as the storefront, were intended to be interchangeable or “upgradable” for the desired market, different retailers, and/or internal subdivision of the building. Storefronts have materials or branding that were applied later in a building’s life that may have gained historic significance due to their originality, store name, or architectural style. Changes and additions to residential are often more subtle. Those which are significant to preserve can tell the story of who lived there and can include small feature changes, style changes, or complete alterations with necessary modifications such as internal kitchens, bathroom additions with new plumbing or car-ports. The decision to remove any prior added elements should take into account the original building’s condition (why did it need changes?) and the potential for irreparable damage caused by the changes themselves.

Exact replication of historic building styles with new construction to “fool” the viewer (“theme”ing or creation of a “false sense of history”) is discouraged.



Conway, 2009

The historic environment west of Elm Street along Fourth, comprised of mid-20th century “modern” architecture, represents the changing social functions and expansion of downtown from pedestrian-oriented into auto-oriented architecture and corridors.



Conway, 2009

In the early 2000s resurgence of the downtown led to the addition of a 2nd floor to this traditional one story, one-part commercial bldg. Visual queues were left to delineate where old and new differ and the upper floor stepped back.



jB-ra photo archives

Some buildings have had changes imposed on them. Example above: ca.1940 tiled facade over 1900 brick. Changes might have merit and damage underneath may be costly to repair. Understand each project before beginning.



Conway, 2009

Often storefronts are different from the time period of the building and represent change of use, style or marketing over time. Highly stylized features can be significant to tell the story of retail history in Conway.

New buildings that respect the predominant forms, scale, setting and materials in context to their immediate surrounding (see Section A, Chapter 1.6) can be designed using contemporary elements to allow the Conway local historic district to retain character and support new architecture.

In spite of visible layers of history, buildings can qualify for Historic Preservation Rehabilitation Tax Credits (See Appendix V, “Financial Incentives for Historic Preservation”). Each respective layer must be identified, interpreted and maintained with the appropriate measure sensitive to its period of significance. For example, an 1890s brick commercial structure that has retained its late-Victorian era details may be identified maintained for its wood windows and porous brick surface. Yet, a leaded glass storefront transom with copper frames installed in the 1920s and post-WWII original raw-aluminum display cases from 1946 could also be retained and repaired with methods that are appropriate for their respective eras. The entire storefront could be researched to any of the periods, and if found significant enough to the approval of the Community Appearance Board, restored to that period. **There are no “blanket” answers, nor “one size fits all” standards for the entire Conway district.**

Today, saving what is original and invaluable is paramount, and change at the cost of losing history should not occur. These guidelines will help determine what is relevant to study and preserve, case-by-case.

2.1. Project Planning and Preservation Practices

Levels of Preservation Effort

“Preservation” is defined as taking the action needed to retain a building, district, object or site as it exists at the present time. Levels of preservation effort include different practical and philosophical aspects to achieve this outcome, from preventing further deterioration or loss of significant historic elements, all the way to highly-researched restoration techniques. Any work that is completed for every level of effort should always follow “best practice” preservation principles (see Secretary of the Interior’s

Standards on the next page.)

How is the proper level of preservation effort chosen for a specific project? The condition of the property, the degree of authenticity, the significance of the property, the desired outcome and the amount of funding available usually dictate “how” one preserves a historic property. Following is a list of four accepted preservation levels by the National Park Service:

1. Stabilization

This begins with making a building weather resistant and structurally safe, enabling it to be rehabilitated or restored in the future. Stabilization techniques include covering the roof and windows so that rainwater cannot penetrate, removing overgrown vegetation, pest control, carrying out basic structural repairs, securing the property from vandalism and other steps to prevent additional deterioration of the property. For a building that is not currently in use, a common stabilization approach would be to “mothball” the building until a suitable use is found (see Section F, Chapter 11.5 “Stabilizing (‘Mothballing’) Structures.”)

3. Restoration

Restoration is practically a science. This method involves returning a building to its appearance during a specific time in its history by removing later additions and changes, replacing original elements that have been removed, and carefully repairing parts of the building damaged over time. Restoration is a more accurate and often more costly means of preserving a building. It entails detailed research into the history, development and physical form of the property; skilled craftsmanship; and attention to detail.

2. Rehabilitation

Rehabilitation involves undertaking repairs, alterations, and changes to make a building suitable for contemporary use, while retaining its significant architectural and historical features. Rehabilitation often includes undertaking structural repairs, updating the mechanical systems (heating and air conditioning, electrical system, and plumbing), making additions for bathrooms, and repairing damaged materials such as woodwork, roofing, or paint. Rehabilitation can accommodate the adaptive use of a building from residential to office or commercial use. Physical changes, such as additions for offices, parking and signage, may result. Good rehabilitation projects make changes in a way that does not detract from the historic character and architectural significance of the building and its setting.

4. Reconstruction

Potentially this can be the most philosophical and controversial of the preservation methods. Reconstruction entails reproducing, by new construction, the exact form and detail of a vanished building or part of a building as it appeared at a specific time in its history. Generally it would be considered creating “a false sense of history” to use aged materials, which can fool a viewer of the exact age of a building. The Secretary of the Interiors Standards also make it possible for “contemporary-compatible” construction, where expressly contemporary materials are used in a traditional form in context to what it is either replacing or with the immediate surroundings. When reconstructing elements that are missing from historic architecture, it should also be done with distinctly modern materials in scale, placement and form based on evidence as not to “falsify history” with subjective decoration.

2.1. Planning and Principles (continued)

The Secretary of the Interior's Standards

The U.S. Secretary of the Interior's "Standards for Historic Rehabilitation" were initially developed for use in evaluating the appropriateness of work proposed for properties listed in the National Register of Historic Places. First developed in 1976 and revised in 1990, the U.S. Secretary's Standards for the Treatment of Historic Properties are considered the basis of sound preservation practice. The standards allow buildings to be changed to meet contemporary needs, while ensuring that those features that make buildings historically and architecturally distinctive are preserved. The stan-

dards have meaningful application to virtually every type of project involving historic resources (see Levels of Preservation Effort previous page).

The Secretary of the Interior's Standards for Rehabilitation provide the framework for these design guidelines and will be used by the Community Appearance Board in reviewing applications for Certificates of Appropriateness. These standards are:

1. A property shall be used for its historic purpose or be placed in a new use that requires minimal change to the defining characteristics of the building and its site and environment.

2. The historic character of a property shall be retained and preserved. The removal of historic materials or alteration of features and spaces that characterize a property shall be avoided.

3. Each property shall be recognized as a physical record of its time, place, and use. Changes that create a false sense of historical development, such as adding conjectural features or architectural elements from other buildings, shall not be undertaken.

4. Most properties change over time; those changes that have acquired historic significance in their own right shall be retained and preserved.

5. Distinctive features, finishes, and construction techniques or examples of craftsmanship that characterize a historic property shall be preserved.

6. Deteriorated historic features shall be repaired rather than replaced. Where the severity of deterioration requires replacement of a distinctive feature, the new feature shall match the old in design, color, texture, and other visual qualities and, where possible, materials. Replacement of missing features shall be substantiated by documentary, physical, or pictorial evidence.

7. Chemical or physical treatments, such as sandblasting, that cause damage to historic materials shall not be used. The surface cleaning of structures, if appropriate, shall be undertaken using the gentlest means possible.

8. Significant archaeological resources affected by a project shall be protected and preserved. If such resources must be disturbed, mitigation measures shall be undertaken.

9. New additions, exterior alterations, or related new construction shall not destroy historic materials that characterize the property. The new work shall be differentiated from the old and shall be compatible with the massing, size, scale, and architectural features to protect the historic integrity of the property and its environment.

10. New additions and adjacent or related new construction shall be undertaken in such a manner that if removed in the future, the essential form and integrity of the historic property and its environment would be unimpaired.

A OVERVIEW

Chapter 2 HOW TO USE THESE GUIDELINES

2.2. Certificate of Appropriateness CAB Approval Matrix

(NOTE: Planning Staff has option of forwarding any action to CAB if it feels necessary.)

Certificate of Appropriateness Approval Matrix - CAB Historic Design Review Districts				
ACTION (Item #)	Administrative Review with Documentation	Requires full CAB Review COA Required	Building Permit Required?	Quick Reference: Guideline Section & Pg. #
1) Additions / New Construction		X	Yes	B.6-7&24-26, D.18-19, E.12
2) Accessory structures (sheds, garages, etc.)...				
...IF New, Visible from the street / any size, or demolition		X	Yes	B.25, D.20, E.12
...IF New, Not Visible from the street	X		Yes	B.18, B.25, D.20. E.12
3) Awnings and Canopies ...				
...IF FABRIC is damaged / ripped - needs basic Retention / Repair / Recover Fabric	X		No	B.22 & 23
...IF STRUCTURE and/or rigid support is Retained or Bracing needs basic Repair	X		Varies	B.23, E.11
... IF NEW installation / design or Change of canopy type (shape, profile, frame)		X	Yes	B.23, D.11, E.11
4) Balconies (New installation or repair. See also Windows - new openings)		X	Yes	B.24, B.26
5) Carports (addition or enclosure off rear alleys only)		X	Yes	B.18
6) Cornices & Coping (Storefront or Upper Facade)...				
...IF Retaining / Repair with same material (See also (24) Painting)	X		Yes	B.5, B.14, B.16
...IF Restoring original configuration with new materials	X		Yes	B.5, B.14, B.16
...IF NEW / any location		X	Yes	B.5, B.14, B.16, E.10
7) Curb Cuts	X		No	
8) Decks, Porches and Patios ...				
...IF Retaining / Repair with same material (See also (24) Painting)	X		Varies	B.26, D.11&12, E.11
...IF NEW installation / Design - attached to structure		X	Yes	B.25-26, D.18
...IF NEW - not attached to structure	X		Yes	D.16, E.11
9) Decorative Shutters ...				
... IF Repairing / Replacements, same material and size	X		No	D.9, E.9
... IF NEW Feature		X	No	D.9, E.9
10) Demolitions (part or all of structure)		X	Yes	Section F
11) Doors / Garage Doors ...				
... IF Retaining / Repair with same material (re-painting - see also (24) Painting)	X		No	B.10, B.19, D.8, D.20, E.8
... IF Replacing with New material - same size, shape, configuration, profiles		X	Yes	B.10, B.19, D.8, D.18-20, E.8
... IF Installing new units with change in appearance, style or fit withing opening		X	Yes	B.10, B.19, D.8, D.18, E.8
... IF Creating any change in openings (Also see Displays - Storefront opening)		X	Yes	B.10-11, B.19, D.8, D.20, E.8

(Matrix continued on next page)

(NOTE: Planning Staff has option of forwarding any action to CAB if it feels necessary.)

Certificate of Appropriateness Approval Matrix - CAB Historic Design Review Districts (Continued from prev. Pg.)				
ACTION (Item #)	Administrative Review with Documentation	Requires full CAB Review COA Required	Building Permit Required?	Quick Reference: Guideline Section & Pg. #
12) Driveways and/or Parking Pads ...				
... IF Repairing same surface	X		No	D.16
... IF NEW construction, Replacing surface, Change in material, or Relocation		X	Yes	D.1, D.16, E.5
13) Equipment (antennas, satellite 18" or less, HVAC, refrigeration, exhaust, etc.)	X		varies	B.19
14) Exterior - Walls, Piers, Siding, Upper Facades (clapboard, stucco, brick, etc.) ...				
... IF Retaining / Repair with same materials (See also Painting, Re-pointing Masonry)		X	Varies	B.14, B.16, B.20, D.13-14, E.12
... IF Replacing (Covering) with new materials (See also Painting)		X	Yes	B.16, B.18, B.20, D.13-14, E.12
15) Exterior Façade Change (Incl. style changes) ...				
... IF Retaining / Repair with same material, any part of structure	X		Varies	A.9, B.11-13, B.20, D.13-14
... IF Replacement of non-historic materials (Restore original config.)		X	Yes	A.9, B.13, B.20, D.13-14, E.12
Façade - Commercial (see Storefront or (15) Exterior Façade Change)				
Façade - Rear (See Rear Façade)				
16) Fences or Gates ...				
... IF Retaining / Repair with same material, any part of structure	X		Yes	D.16
... IF NEW Construction, Change in materials, or Relocation		X	Yes	D.16, E.11
17) Fire Escapes, new or change in materials or location		X	Yes	B.26, D.7
18) Fountains ...				
... IF Repairing with same materials	X		Yes	D.16
... IF New or visible from street		X	Yes	D.16
19) Gutters & downspouts ...				
... IF Retaining / Repair existing or replace w/same material (or adding gutter covers)	X		No	B.18-19, D.15
... IF Adding NEW or replacing with new materials	X		No	B.18-19, D.15
Interiors ...				
Decorative changes			N/A	N/A
Ad Valorem Tax Exemption (State Review See Appendix)		voluntary	Varies	N/A
Historic Rehab Tax Credits (State & NPS Review See Appendix)		voluntary	Varies	N/A
(Matrix continued on next page)				

A OVERVIEW

Chapter 2 HOW TO USE THESE GUIDELINES

(NOTE: Planning Staff has option of forwarding any action to CAB if it feels necessary.)

Certificate of Appropriateness Approval Matrix - CAB Historic Design Review Districts (Continued from prev. Pg.)				
ACTION (Item #)	Administrative Review with Documentation	Requires full CAB Review COA Required	Building Permit Required?	Quick Reference: Guideline Section & Pg. #
(20) Landscaping ...				
... IF Planting/minor change (any plant material visible from the street)			N/A	D.16
... IF Planting/major removals or major site plans (visible from the street)	X		No	D.16
... IF Tree Removal/moving or adding mature trees anywhere on property		Tree Board	Tree Permit	N/A
... IF Adding or Modifying Landscape Lighting	X		Yes	D.16
(21) Lighting (Building or on-site, Reproduction, Replacement or New Installation)	X		Varies	B.9, B.11-12, B.16, D.10, E.4
(22) Masonry (brickwork) Re-pointing, Repair	X			A.11, B.20-21, D.14, E.7
(23) Mechanical Systems, HVAC & Window Units, exhaust fans, etc....				
... IF Replacing or repairing existing unit with same type	X		Varies	B.17-19
... IF Adding New or Relocating Equipment	X		Yes	B.17-19, B.25, D.19
(24) Painting ...				
... IF Maintaining painted surface or Color change			N/A	B.20, D.14
... IF Painting originally unpainted surface (or removing paint)	X		No	B.18, B.20-21
Parking Lots, pavement (see (12) Driveways and/or Parking)				
(25) Pools (rear yards or roof only)	X		Yes	D.16
Porches (see (8) Decks, Porches & Patios)				
(26) Rear Facade (Facing public alley or rear parking facility) ...				
Service / Delivery Door / Overhead Door (Also see (11) Doors)		X	Yes	B.18-19
Ramps/Lifts		X	Yes	B.18, D.7, E.8
Security Devices (Burglar Bars, Alarm Boxes, etc)	X		Yes	B.18-19
Utilities (electric panels, exhaust fans, grease traps, phone, pipes)	X		Varies	B.19
(27) Relocation of building or structure		X	Yes	Section F
(28) Retaining Walls ...				
... IF Retaining / Repair with same material, any part of structure and/or site	X		Yes	D.16
... IF NEW Installation, Change in material or removal of existing (visible from street)		X	Yes	D.16
... IF Installing new, Changing or removal of existing (NOT visible from street)		N/A	Yes	D.16
(Matrix continued on next page)				

(NOTE: Planning Staff has option of forwarding any action to CAB if it feels necessary.)

Certificate of Appropriateness Approval Matrix - CAB Historic Design Review Districts (Continued from prev. Pg.)				
ACTION (Item #)	Administrative Review with Documentation	Requires full CAB Review COA Required	Building Permit Required?	Quick Reference: Guideline Section & Pg. #
(29) Roofs ...				
... IF Retaining / Repair with same material, any part of structure			Varies	B.17, D.15, E.13
... IF Replacing or Changing shape/material/style of shingle/covering	X		Yes	B.17, D.15, E.13
... IF Altering shape/form of roof, Adding dormers or Change to rooflines/eaves		X	Yes	B.17, B.25, D.15, E.13
Sheds (See (2) Accessory Structures)				
(30) Sidewalks / Walkways ...				
... IF Retaining / Repair with same material, any part of structure or site	X		No	B.6, B.8, D.16, E.4-6
... IF NEW construction, new materials, relocation		X	Yes	B.6, B.8, D.16, E.4-6
Siding (See (14) Exterior ... Siding)				
(31) Signs / Plaques				
		X	Yes	Section C, D.17, E.4
(32) Solar Collectors, Sky Lights ...				
... IF Retaining / Repair or replace with same materials (same location)	X		Yes	E.13
... IF NEW construction, New materials, Relocation (any location)	X		Yes	A.9, B.25
(33) Steps / Stairs (attached to buildings or in yards) ...				
... IF Retaining / Repair or replace with same materials (same location)	X		Yes	B.26, D.16, E.6
... IF NEW installation, Change in size, Design or Repair with new materials		X	Yes	B.26, D.16
<u>STOREFRONTS (Public Commercial - see "Parts of the Commercial Façade" pg. B.4 for Illustrations)</u>				
(34) Storefront - Bulkhead ...				
... IF Retaining / Repair with same materials (See also Painting)	X		Varies	B.4, B.10, B.13
... IF Removing / Replacing with new materials (See also Painting)		X	Yes	B.9, B.10, B.13
(35) Storefront - Displays (Columns, Framing, Transoms and/or Glass) ...				
... IF Retaining / Repair with same materials (See also (24) Painting)	X		Varies	B.4, B.9, B.11
... IF Removing / Replacing with new materials (See also (24) Painting)		X	Yes	B.4, B.9, B.11
(36) Storefront - Opening (Change layout or create new opening)				
		X	Yes	B.4, B.10, B.19, E.8
Storefront - Entry Doors (See (11) Doors)				
Storefront - Transom Windows (See Storefront-Displays (above))				
(Matrix continued on next page)				

(NOTE: Planning Staff has option of forwarding any action to CAB if it feels necessary.)

Certificate of Appropriateness Approval Matrix - CAB Historic Design Review Districts (Continued from prev. Pg.)				
ACTION (Item #)	Administrative Review with Documentation	Requires full CAB Review COA Required	Building Permit Required?	Quick Reference: Guideline Section & Pg. #
(37) Storm Windows and Storm Doors (Removable or suppliment to main units)...				
... IF Installing or removing for normal weatherization			N/A	
... IF Retaining / Repair with same materials (See also (24) Painting)	X		Yes	B.12, B.15, D.9, E.9
... IF Installing NEW or Changing materials		X	Yes	B.15, D.9, D.11, E.9
(38) Trim (Scrollwork, fascia, banding, decorative vents, columns, etc.)				
... IF Retaining / Repair with same materials (See also (24) Painting)	X		No	B.11, B.13, D.12
... IF Replacing - same material, size, shape, configuration	X		varies	B.13, D.12-13, E.12
... IF Replacing with NEW material - same size, shape, configuration		X	varies	B.13, D.12-13, E.12
... IF Installing NEW, or Change in size, style, design or profiles		X	Yes	B.13, D.12-13, E.12
(39) Windows ...				
... IF Retaining / Repair with same materials (see also (24) Painting)	X		Yes	B.11-12, B.15, D.9, E.9
... IF Replacing with NEW material - same size, shape, configuration, profile		X	Yes	B.11-12, B.15, B.24, D.9, E.9
... IF Removing non-historic materials (to Restore original config.)		X	Yes	B.11-12, B.15, D.9, E.9
... IF Installing new units with change in appearance, style or fit withing openings		X	Yes	B.24, D.9, E.9
... IF Creating New openings, Change in size of openings, or New material		X	Yes	B.5, B.8, B.24, D.9, E.9

2.3. How to Apply for a Certificate of Appropriateness

Any property owner or occupant interested in making a “material change in appearance” (as defined by the CAB reviewable items listed in their Duties and Powers, *City of Conway Unified Development Ordinance*, Article 14.1.2) to any building, structure or site within a locally designated Historic Design Review District **must submit an application to the CAB for a Certificate of Appropriateness (COA) (Appendix III “Forms”)** before a building permit can be issued. Demolition, relocation and new construction within local Historic Design Review Districts also requires a COA.

Depending on application scope or complexity (see COA Approval Matrix A.12-A.16), Administrative Approval or CAB Design Review will occur.

A public record shall be kept of the Community Appearance Board’s resolutions, proceedings, and actions with the City of Conway.

(Also see the flowchart at the end of this Chapter (Figure 1.2) and the *City of Conway Unified Development Ordinance*, Article 14 in Appendix II.)

SUMMARY OF A PROPERTY OWNER’S APPLICATION PROCESS (From City of Conway Unified Development Ordinance, Article 14, reprinted in Appendix II)

1: REQUIRED INFORMATION

Each application for a Certificate of Appropriateness shall be made by first contacting the City Planning Department to ensure there are no new requirements and/or pick up an application for the process. **Each applicant shall submit two copies of all relevant information** deemed necessary by the CAB and/or the Planning Staff in order for the Board to approve or deny the application. [Full lists of these suggested items are found in the Reference Section, Appendix II of these guidelines “Conway Historic Preservation Ordinance”] OR go to www.cityofconway.com

2: RECORDS

A public record shall be kept by the Community Appearance Board’s resolutions, proceedings, and actions in such a place as other public records are kept.

3: “CONCEPTUAL REVIEW” (based on CAB Approval Matrix pgs. A.12-A.16)

Applicants are encouraged to meet with the City of Conway Planning Department prior to the preparation of working drawings and specifications, at the time of the application process. The purpose of the meeting shall be to familiarize applicants with the City of Conway CAB and the design review standards. **From this point, Administrative Approval by the City Planner or staff may all be that is required to obtain zoning permit.**

4: “PRELIMINARY REVIEW” DEADLINES

To be placed on the CAB agenda, an application for COA must be completed and submitted **10 days prior to the next scheduled meeting of the CAB Historic Districts Design Review Session (held on the 2nd and 4th Wednesday of each month)** for the CAB to perform a “preliminary review” of each application to ensure it adheres to design review criteria, required information submitted, and these Community Appearance Guidelines. If revisions are required the applicant shall be notified.

5: “FINAL REVIEW” DEADLINES

The CAB Historic Design Review is held on both the 2nd and 4th Wednesday of each month (unless otherwise noted - check with City of Conway Planning Dept. or website www.cityofconway.com). The applicant or legal representation must appear. The CAB shall approve or deny an application for a COA, or place conditions upon which must be agreed to and met for the issuance of a zoning permit. [Order of business for consideration of applications for COAs, exemptions, enforcement, penalties, etc., are found in the Reference Section, Appendix II “Conway Zoning Ordinance.”]

6: ADVERTISING

CAB staff will post a notification sign on every applicant’s property stating that the property is in review. If a hearing before CAB is required, the staff shall place an advertisement in the legal organ of the county which will be published before the meeting of the CAB. The staff shall transmit the application, together with all other supporting information, to the City of Conway Planning Department.

7: CAB DECISION

The Community Appearance Board (CAB) may consider, but shall not be bound by, precedent. Each case shall be decided upon its merits, applying the Ordinance and design guidelines. The CAB will approve, approve with conditions, or deny an application for COA completed and filed in the above process.

8: APPEALS

Appeals to the CAB may be taken by any person aggrieved by a decision of the City Planner relating to design standards (within 30 days from date of decision). A person who may have substantial interest in any decision of the CAB or any officer or agent thereof may appeal to the circuit court in Horry County, SC (filed within 30 days after the decision of the CAB). [See full rules of appeals in the Reference Section, Appendix II of these guidelines.]

2.4. Design Review Process Flowchart

Fig. 1.2: Conway Historic District Design Review Process

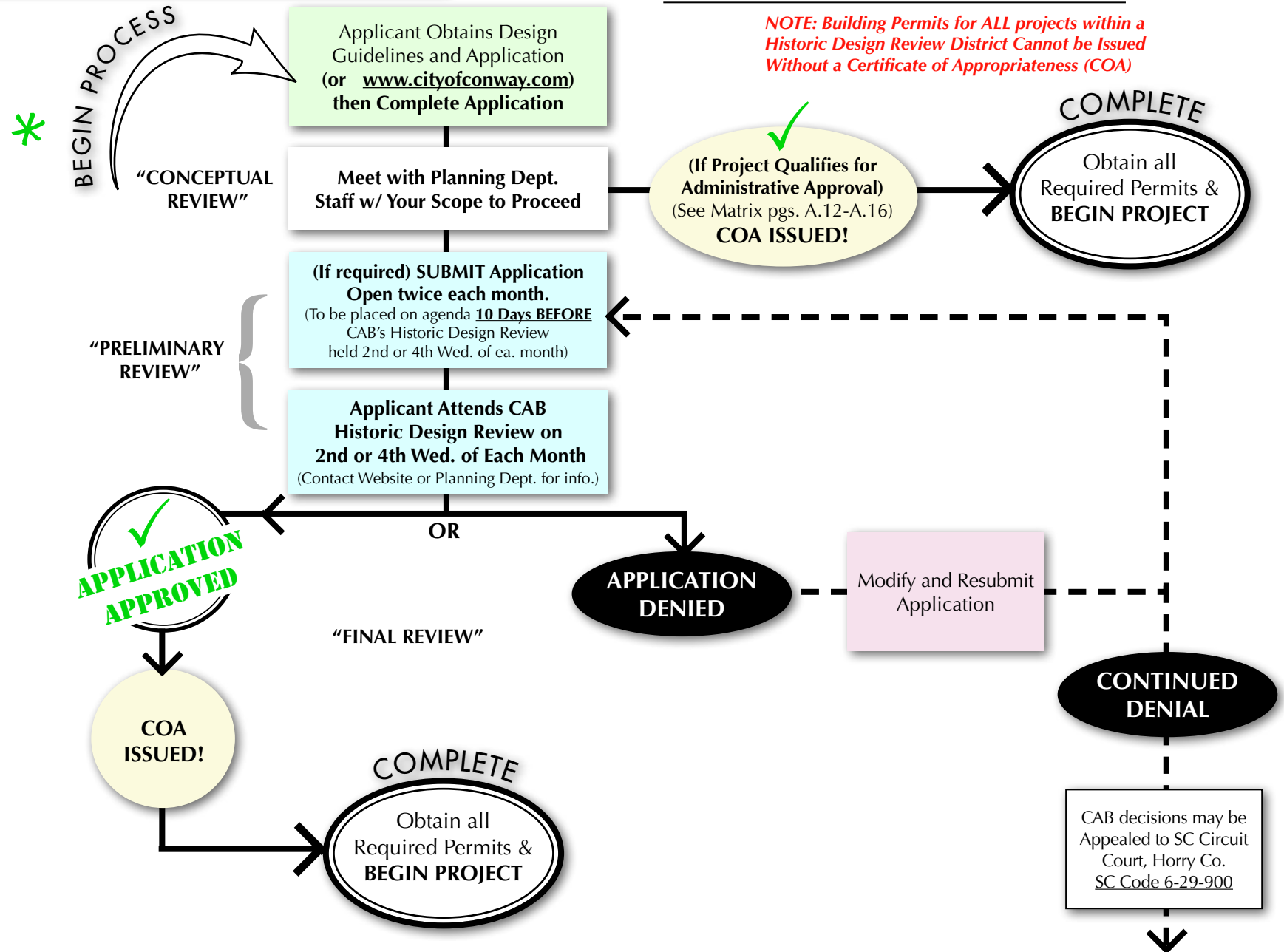

SECTION B

COMMERCIAL HISTORIC DESIGN REVIEW DISTRICT GUIDELINES

Chapter 3:
Basics of Traditional Commercial
Buildings

Chapter 4:
Commercial Rehabilitation &
Architectural Guidelines

Introduction

Conway Historic Design Review Districts (Commercial, Waccamaw River-front and Main Street Corridor) contain a diverse stock of commercial building forms and significant architectural styles. This section is intended to set consistent design standards that maintain the traditional commercial building forms in these local historic districts. Design Guidelines are not intended to limit creativity in design. Rather, they are created to help building owners and/or proprietors understand their unique building features that will largely define the appropriate arrangement of traditional storefront details and placement of architectural amenities.

By following this section of the guidelines, each and every storefront can work as an individual statement while contributing to each historic Design Review District as a whole and in coordination with neighboring buildings. In some areas of the Conway Downtown Historic District residences are zoned for professional use (i.e. adaptive use of historic homes for businesses within the Main Street Corridor Design Review District, along N. Main Street and in the SE blocks of the Commercial Design Review District). Buildings originally created for industrial uses should take in consideration the context of their unique construction and the historically specialized environments they may have been built in (such as those throughout the Waccamaw Riverfront Design Review District).

Conway's Historic Downtown Overview

Conway is one of the oldest towns in South Carolina. The town was laid out in 1734 on a bluff over the Waccamaw River and named "Kingston" in honor of King George II. Shortly after the Revolutionary War, in an attempt to shed associations with the British monarchy, citizens changed the town's name to Conwayborough in honor of General Robert Conway, and Kingston Township was renamed Horry County to honor General Peter Horry. Conwayborough was a bustling river port town throughout the 1800s involved primarily in the production of tar, pitch, and turpentine in the naval store industries. Riverboat service connected Conwaysborough to Georgetown, SC in Winyah Bay downriver. The renowned architect Robert Mills (1781-1855) designed the Old Horry County Courthouse, now known as Conway City Hall, which was completed in 1825. Robert Mills also designed the Washington Monument in Washington, DC.

In 1883 the South Carolina General Assembly shortened the town's name to Conway and in 1887 the railroad reached Conway. The rail line conformed closely to the river's route and improved Conway's inland connects. Most of Conway's rail traffic has historically been industrial rather than passenger-oriented. Much of the present downtown was built in the early 1900's likely as a result of railroad traffic. Conway's waterfront prospered from warehousing between river and rail traffic.

Today, across the nation, there is a renewed interest in the revitalization of downtowns, with many people choosing to live closer to and within central



Conway from the 1930s Waccamaw River Bridge, 2010

business districts. As a designated Main Street community through the National Trust for Historic Preservation, Conway has proudly preserved its history and spurred downtown revitalization. Without appropriate guidance and education, however, a city's historic resources and visual character can be lost through piece-meal renovations and rehabilitations. As each building and storefront rehabilitation or restoration is addressed, it should be understood that proposed work is an individual statement of the combination of the original intent and the significant commercial changes over time. Each unique developmental period should be taken into account by the building owner and the HPC while respecting the district's history as a whole.

3.1. Commercial Forms vs. Applied Styles

While these guidelines are intended to guide the physical elements of each facade, two major definitions of how to “read” a building and determine its original intent must be made. Building *form* and the *style* of its architectural details are two separate aspects, and each determines how buildings would be rehabilitated, restored or reconstructed today. Both can be used as a dating tool.

FORM:

Closely associated with building “type,” which focuses more on use, the building *form* is largely defined in plan, arrangement of its functional spaces, and sometimes its social connotation. For example, the form of a traditional commercial building differs from that of the traditional form of a church, a firehouse, post office, gas station, etc. (see Section B, Chapter 3.2 “Commercial Building Forms”). When defining form, it may simply be the overall shape, number and sizes of openings, what they may have been used for, and bays (physical divisions of buildings defined by windows, walls, or lines of support columns).

An example of describing the form of a commercial building could be:

“A two-story, central block, two-part commercial building with 4 evenly spaced 4 x 7 foot upper-story windows each over a 30-foot wide double-bay storefront (both consisting of angled recessed display and centered double-door entry) along with a right side (facing) single front entry door leading to an interior side hall and stairs to the upper floor.”

Predominant Commercial Building Forms In Conway’s Historic Districts

- One Part Commercial
- Two Part Commercial
- Business Block (hotel/lodging, theatre complex, dept. store, etc.)

“Stand-Alone” Building Forms:

- Warehouse / Shed (near the Waccamaw Riverfront District)
- Railroad Structures (Service Sheds, Freight Structures)
- Auto-Service (Gas Station / Garage, Auto Parts, Car Dealer)
- Office / Institutional (Bus Station, Courthouse, Post Office, City Hall, etc.)
- Industrial / Post & Beam box (Cafeteria, ice house, Grocery Store, etc.)
- Churches.

STYLE:

Building or architectural *style* is a matter of the intended choice of decorative embellishments and adornments that were socially driven by the “high styles,” materials and technologies of the period in which they were built. Different styles can overlap within the same time period, due to architects and building owners selecting the style that best defined the type of business being conducted or the level of sophistication they wanted to portray to their intended patrons.

Often, the original intended style is built into the fabric of the building with the choice of exterior cladding, treatment of the foundation material, proportions of the arrangement of elements and the shape of the window openings. However, style is also portrayed in the choice (or necessity) of, and not limited to, certain window sash and glass divisions, door styles, brackets, applied artistic details, tiles and original intended amenities such as awnings, railings, light fixtures, hardware or signage.

Significant Historic Building Styles Applied to Commercial Properties

- | | |
|-------------------------------|--|
| • Italianate Victorian | • International |
| • Romanesque Revival | • Minimal Traditional |
| • Refined Classicism | • Contemporary |
| • Neoclassical Revival | • “Googie” or “California coffee-shop” Commercial (Cafeteria & various businesses on Main St. near Sixteenth Ave.) |
| • Dutch Colonial | |
| • Arts and Crafts (Craftsman) | |
| • Art Deco | |
| • Art Moderne | |
| • Colonial Revival | |

3.2. Commercial Building Forms

One-Part Commercial

Generally, a one-story commercial building. This is a stand-alone shop or one structure of multiple storefronts with subdivided individual or internally connected stores, one within each bay from the facade back.

Two-Part Commercial

Typically, and most traditionally, a “two-part commercial” building is the most recognized form of “Main Street America.” As the name implies, uses of the structure evolved into two parts, one for retail (generally street level) and the other for storage, offices, or residential (generally above), which can be two to five stories. Generally built to have shared “party” sidewalks to either side (all of Main Street) they can form a “line” of individual buildings with only their facades visible along the street. The Two-Part Commercial form creates an efficient, dense environment of mixed uses in the vibrant city center. Brick party walls help with fire separation and keeping all levels of the building’s retail, stock and administrative functions contained.

The “Business Block”

The row of independently owned and managed two-part commercial structures quickly turned into fully developed, unified building complexes taking entire blocks with multiple leased, usually vertically mixed, uses. Historically, entertainment or gathering spaces would be incorporated in the upper stories or behind the rows of integrated street-level retail with entries for all uses designed into the street-level primary facade. Masonic lodges, which often began as early two-part commercial forms in downtown, as well as theaters, corporate offices, banking, hotels, and larger department stores expanded into “business block” commercial form structures.

Other Forms of Commercial Buildings

There are many other stand-alone commercial buildings found in different sectors of the downtown. Aside from the traditional commercial building forms, other types of structures found in downtown Conway are service stations, garages, hotels, river-warehouse structures, City Hall, churches, and civic/institutional buildings. Their intended individual use defines their form.

Fig. 2.1: Most Predominant Building Form Examples



Conway, 2010

(Above) **One-part commercial**, “single bay” building in downtown Conway on at the NE corner of 3rd Ave. and Elm Street.



Conway, 2009

(Below) The 3-story building at the corner of 4th Ave. and Laurel St., is a good example of **two-part commercial form** (not held to only 2 stories) as “two-part vertical use” (storefront and upper floors).



Conway, 2009

(Above) A larger scale, “**business block,**” takes up the majority of the block it is located on. Access from the sidewalk leads back into the interior and separate upper floors where a mix of uses (perhaps offices, residences, hotel, theatre, etc.). Completely separate shops and office space line the facade at street level.

(Below) Two images of “**stand-alone commercial architecture**” (not just in the Commercial HDRD). Unique to Conway are the historic warehouse structures (top) at the border of the Commercial and Waccamaw Riverfront HDRD. Single story professional and auto-related businesses (bottom) are fairly vernacular and found throughout the Commercial and Main Street Corridor HDRDs..



Both Images, Conway: 2010

3.3. Parts of the Commercial Facade

The “3-Part Facade” defines the vertical sections of most primary commercial facades facing the street or the patron (Figure 2.2). The facade is divided into three sections: storefront, upper facade and cornice. These divisions can be found across hundreds of years of construction and styles up to the present day. The uses and context of the main parts follow:

The Storefront

The storefront is the where the facade “interacts” with the patron, set between structural building piers, pillars, or pilasters that is generally glass and wood or metal framing. The essential purpose of storefronts are to promote goods in display windows and often provides entry to the interior shop space of the building (Figure 2.3). It has a marketing role as well as a functional role, and therefore street-level storefronts have traditionally been altered much more than any other part of the facade, due to the nature of retail. There can be multiple storefronts on one building.

The storefront’s marketing role is the display, which contains its own set of parts: doors, bulkheads, windows and sometimes transoms. Functionally the storefront provides access to the business and historically provided natural light and ventilation through high transom windows over the displays. If buildings faced north transom windows were generally designed taller or mounted higher over exterior awnings since these buildings benefit from the least year-round light. The use of transom windows diminished over time with the advent of modern lighting and air conditioning, and by the mid-20th century they are practically phased out of design. The storefront styles of these later periods become lower to express their modernity.

Overall, the storefront frames the shop. Earlier styles decorate the structural parts, such as columns and window frames, in the style of the building’s architecture. Later, storefronts were constructed or updated using more functional materials such as sleek copper or aluminum trim and full glass, as steel header beams replaced wood and the need for multiple columns. The storefront also usually contains an area above the framed store opening called the sign band, and above this typically some form of visual separation in the form of a material beltcourse or attached storefront cornice. These elements also visually divide the storefront level from the upper facade and serve to “cap” the storefront.

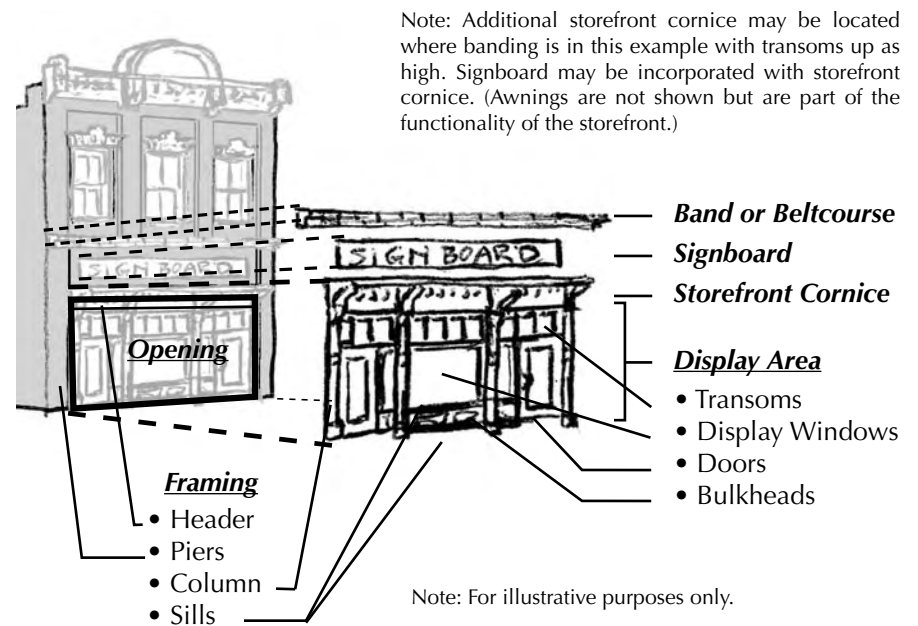
Fig. 2.2: Illustrated Divisions of the “3-Part Facade”*Fig. 2.3: Illustrated Components of the Storefront*

Note: For illustrative purposes only.

3.3. Parts of the Commercial Facade (continued)

The Upper Facade

The upper facade can consist of any area or floors of the building above the storefront/street level until the point where it meets the cornice. In the earliest forms this would have been a simple wood frame that essentially masked the front gable end of the roof line and provided sign space on a squared off tall facade wall. Window openings, spacing, and arrangement of details among the upper stories create a rhythm to the facade, especially when aligned with neighboring facades along a full block. The upper facade usually consists of at least one floor of upper windows; however, it may also be a tall, window-less facade area that covers a high parapet wall or false front covering the roof line. With multiple floors, the window rhythm is usually repeated. This area may contain pilasters or vertical protruding half columns leading down to the building piers that meet the sidewalk to emphasize height. This is where much of the architectural ornamentation will be found, with features such as arches, stone detail and insets for business signs.

The Building Cornice

The upper cornice is the visual “crown” along the top parapet edge of the primary facade. This decorative and/or stylized element can be attached, applied or a built-up extension of the exterior wall material. Functionally this feature was part of the coping, or cap material, to provide protection or a drip edge to the top of the upper facade parapet wall. When two-part commercial structures began to share adjoining side walls, necessitating flat roofs, the facade parapet wall became an area where a decorative cap gave visual interest to the building’s flat edge. Nineteenth-century commercial buildings commonly used corbelled courses of brick at the top of their brick walls. This was superseded by fashionable, ornate mail-ordered cast iron; followed by stamped metal assemblies by the turn of the 20th-century; then terra-cotta forms on steel frames in the early 20th-century; only to return to inset masonry materials and refined flush surfaces of simple material changes such as inlaid brick in the mid- to later-20th-century. The taller a building is, generally the more elaborate the cornice arrangements. Some buildings of five to twenty or more stories use the entire top floor(s) to define the top, or “capital” to the “building column.”

Fig. 2.4: Illustrated Components of the Upper Facade

Note: For illustrative purposes only. Upper facade components as shown are not typical of every style.

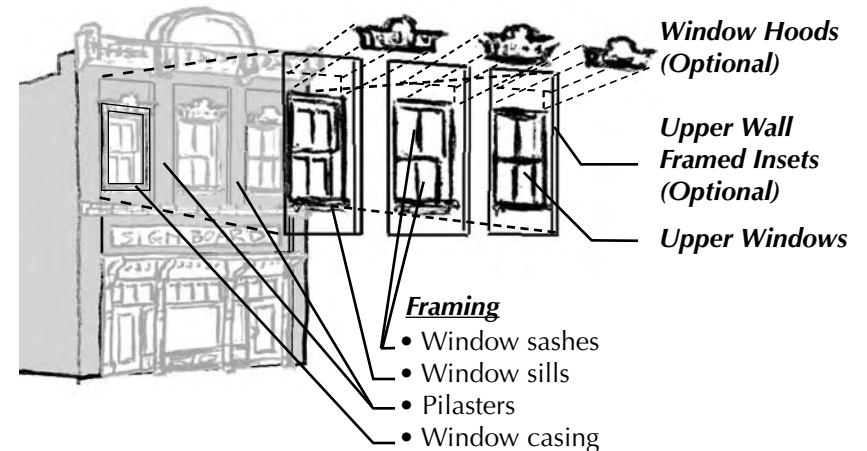
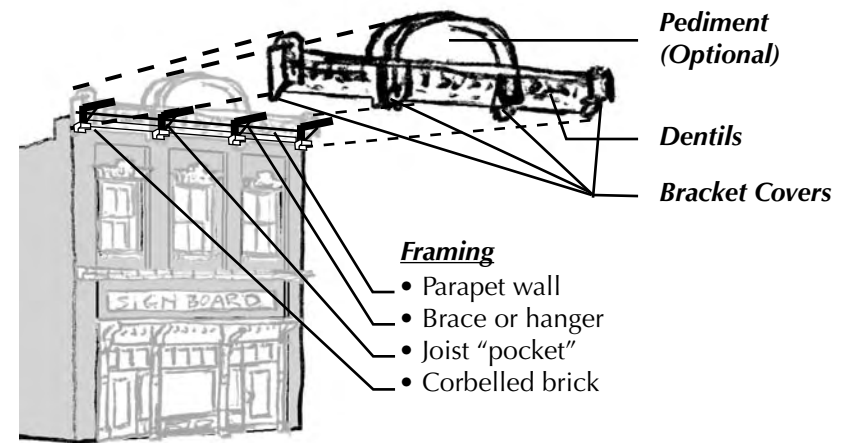

Fig. 2.5: Illustrated Components of the Building Cornice

Note: For illustrative purposes only.



B COMMERCIAL HDRD HISTORIC DESIGN GUIDELINES

Chapter 3 BASICS OF TRADITIONAL COMMERCIAL BUILDINGS

3.4. The Downtown Environment

Downtown is a highly structured architectural environment where it is important to understand the concepts and traditional application of density, set back, building heights, horizontal continuity of building elements and reserving the sidewalk as the "pedestrian hallway."

Density

The downtown environment is dense, regardless of overall community size or how large the central business district is in proportion. Density lends close proximity for the uses, structures, and lifestyle choices of residents and business persons who frequent their downtown. Density helps businesses succeed because it provides continuous and contiguous points of interest.

As a downtown grows and becomes more dense the blocks of buildings can have a layered effect on the perception of the patron or visitor with more interesting buildings continuing around a corner, and larger buildings being in the blocks further from the perceived center of the area. This progression in density is reflected in scale and/or height.

Setback

Traditionally, downtown buildings are built right to the edge of the sidewalk ("zero-lot-line construction") and to the edges of their property boundaries to which commercial structures share adjoining, or "party," walls. New buildings set back varying distances from the front or side property lot lines can offset the rhythm of the "wall" of businesses along the street. If there are existing gaps caused by a variation on building setback these can be filled with landscaping, outdoor seating, or other visually interesting and functional amenities to continue perceived building edge (see below).

APPROPRIATE:



INAPPROPRIATE:

(Note: distance to building edge is filled with landscaping feature.)



The traditional commercial architectural environment in the heart of Conway's central business district (Downtown National Register Historic District - shown above) along with the blocks of 3rd and 4th Aves. from Kingston to Elm Streets, allow for high density. Buildings physically share "party" side walls and are built to the edge of the sidewalk. This creates a context that defines the downtown environment.

Fig. 2.6: Example of Improper Setback in Downtown

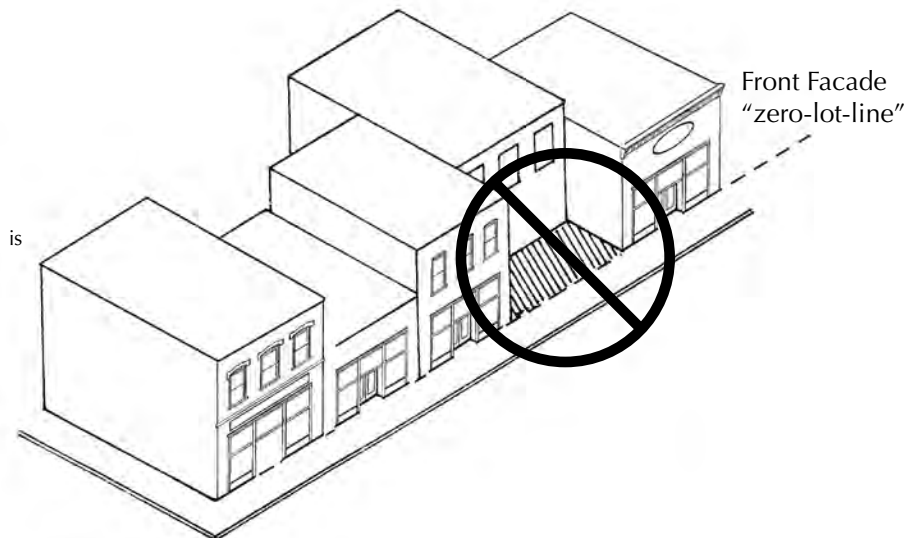

3.4. Downtown Environment (continued)

Building Height

Building height is most important when dealing with infill construction (if for an unfortunate reason a building is lost or there is a vacant lot) and potential building additions (see Section B, 4.6 "Rooftop Additions"). Generally, building height in a traditional downtown, or in individual districts within an area, reflects structures built about the same time in block groupings. Corner buildings are often considered anchors and may have a bit more mass and therefore height. Therefore, the downtown environment has block faces that are generally harmonious in building height and floor alignment. Heights out of scale with the average height originally intended can become inappropriate.

Controlling building height is not meant to prevent new development of greater density or limit building height in downtown. The concept of "height progression" contributes to the downtown's sense of place and wayfinding for the user. It is important to be able to stand in a central place within a downtown (perhaps from a landmark such as the front of City Hall), look out and see a general progression of building heights from this vantage point. The progression of larger buildings behind the earlier, smaller buildings, or built further down auto corridors will give a sense of order. Keeping in mind progression in scale will allow Conway's built environment to be experienced from the heart of the district outward. (Figure 2.7 at right).

Significant smaller, historic buildings should not be visually blocked or overwhelmed by buildings or additions. National Register buildings should especially weigh the importance of height and scale to historic significance.

Infill opportunities on vacant lots are available in many areas throughout downtown Conway. **Current zoning allows new construction in the CBD up to 45-feet, however existing historic construction (see Fig 2.8) establishes a precedent to which new building height may be considered. Generally, variances will not be granted to more than one story taller than the established building height of an area/block.** Higher, dense new construction might be appropriate as infill in the "civic" blocks around the courthouse (or along the outlying Fourth Ave auto corridor, Core Commercial zoning district) with views to the river and into downtown as well as expanding the commercial district.

With historic precedent (surrounding context) and engineering, one-story buildings may be structurally feasible to add second floors (see Section B, Chapter 4.6 "Additions").

Fig. 2.7: Contextual Building Height

Do not add stories to a contributing historic building form that will make it visually distracting to its surrounds.

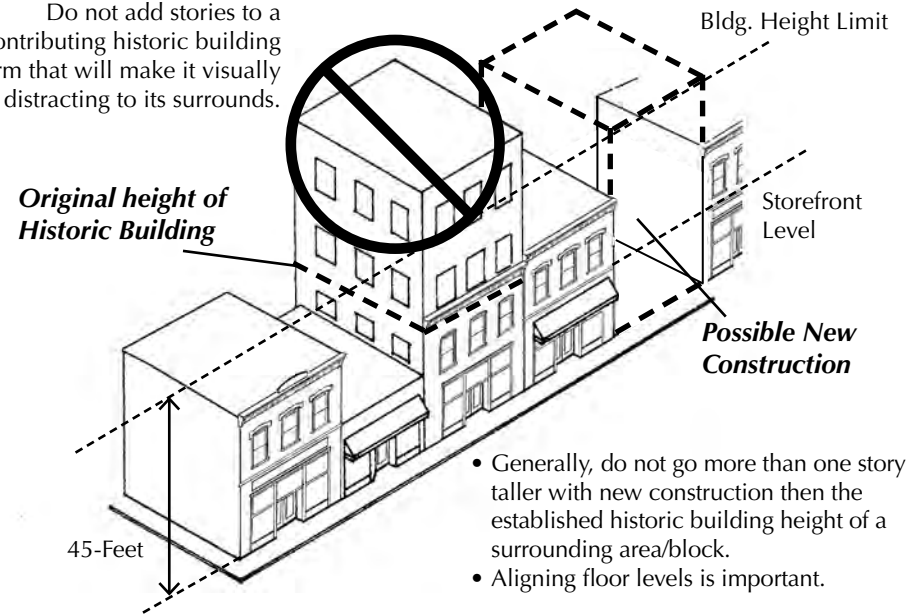

- Generally, do not go more than one story taller with new construction than the established historic building height of a surrounding area/block.
- Aligning floor levels is important.

Fig. 2.8: Examples of Traditional Building Height in Conway



Existing buildings establish a precedent for building heights in downtown Conway (3rd Ave. above left) A precedent for three-story infill on one downtown block (perhaps four-stories would work visually) can be in scale if constructed near to, or neighboring taller structures (illustrated example between the two buildings at the left), while most blocks of Conway's Commercial HDRD buildings remain one- or two-story (above right, also see Fig 2.6). High parapets on upper facades can bring the height of a one story building to almost two stories. Anything must be built within zoning allowance.

“Horizontal Continuity”

Straight lines are harmonious. Modern strip centers utilize this concept well with linear form and signs set at uniform heights. This becomes more challenging in the traditional downtown environment due to independently owned buildings and facades. However, the original builders also understood the success of mass marketing and how clutter confuses the shared pedestrian audience. Coordinating horizontal building elements with neighbors is key. Features which create continuous visual patterns for the pedestrian to scan the downtown marketplace are found in storefront cornices, banded building materials, awning placement and valances, and

banded signs. This is an important reason why retaining and restoring even the smallest building feature is crucial.

For each storefront, it is especially important to align items such as display sills, display frames and even some window signage. If there are sidewalk grade changes, different neighboring horizontal elements might line up, such as transom windows with awnings or sign bands. Note in the figure below the slight grade change along the street. Awning valances and storefronts will reflect this change in horizontal elements (Figure 2.9).

Fig. 2.9: Traditional Horizontal Alignment of Elements

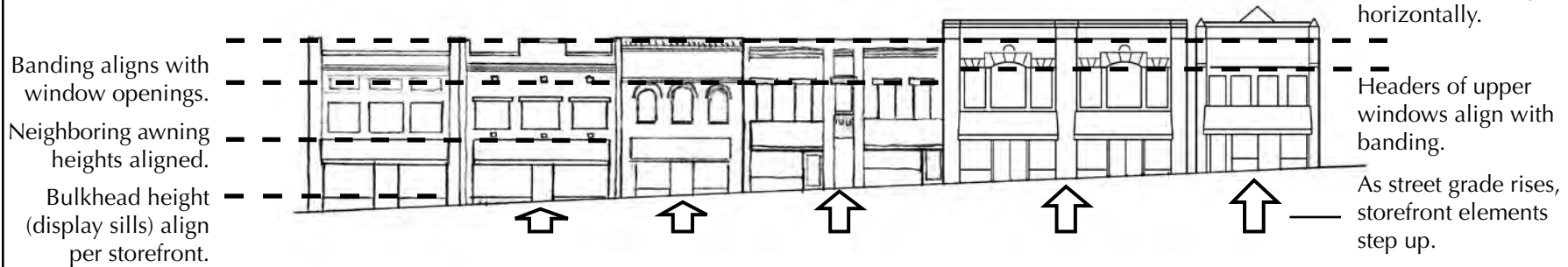

The Sidewalk is the “Pedestrian Hallway”

The pedestrian is the most important asset to the downtown environment, and provisions for the safety and comfort of the pedestrian are key. One continuous “wall” of the pedestrian hallway is formed by the attractive building facades and storefronts. The opposite, perceived wall, is made up of the rhythmic and equally set line of street planting (a mix of shade trees and decorative trees or planting beds is preferred), and/or pedestrian amenities visually separating the sidewalk from the street. Also helping define this perceived wall and making the pedestrian comfortable from moving traffic can be a row of parking, which is usually parallel or angled on wider streets where allowed. Finally, creating the “ceiling” of the hallway is a combination of the lower branches of well-maintained shade trees and the even coordinated projections of the underside of storefront awnings or canopies.

Fig. 2.10: How To Create the “Pedestrian Hallway”

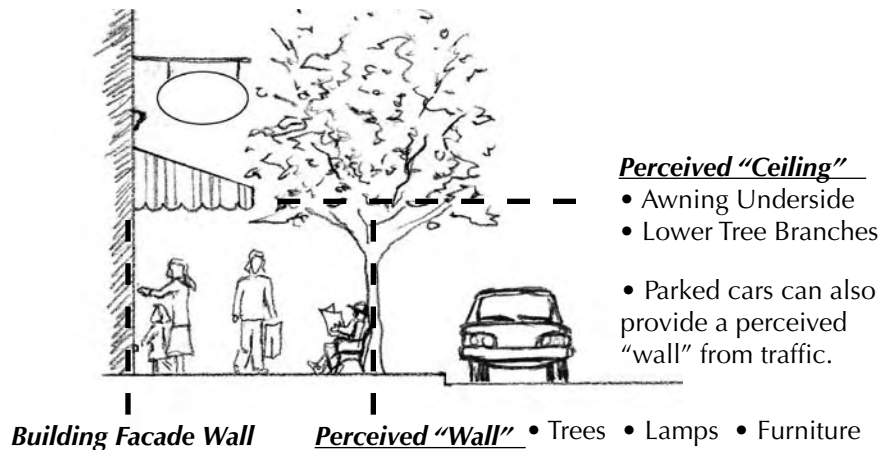

4.1. Storefronts

General Standards



Conway, 2009

Extremely high transomed storefronts of the Victorian period should be opened, treated and restored as such. Older storefronts make use over 80% glass in a relatively small opening.

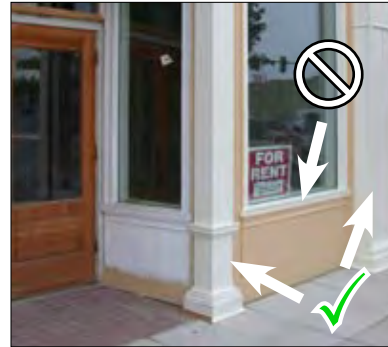

The Georgia Trust: Dalton, 2005

If elements are missing, contemporary materials in the appropriate scale. Here, new wood elements accurately replace the dimensions of a cast iron or timber column, yet the reveal of the sill and inset window frame lack depth.



JB+a Photo Archive

Storefronts are the most converted area of the facade. Drastic changes, removal, insets, coverings, and imposed styles at this level can be out of context and confuse the viewer.



Conway, 2009

Storefronts can become valuable with time, significant to when installed, originality and age/type of bldg. This (ca.1950) storefront on a one-part commrc. bldg. can have younger significance than the bldg. or the near-identical storefront neighbor in a different bldg..

Appropriate

- 4.1.1 Research YOUR individual storefront. Find old photos. Compare configurations and materials to other openings in the building. Note the size of the public facade to scale framing and size of displays.
- 4.1.2 Retain (and repair) rather than replace deteriorated original features.
- 4.1.3 If replacement of parts is necessary due to severe deterioration, replace with features to match (accurately duplicate profiles, massing, scale) in design and materials (Figure 2.11).
- 4.1.4 If the original or intended design of the entire storefront cannot be determined using photographs or historic resources, use contemporary materials with features, proportions, profiles, massing and traditional arrangement typical of similar structures of the same architectural form and style. Traditional storefronts are MOSTLY displays & glass.
- 4.1.5 Assess significant storefront arrangements of later periods that use quality materials (such as irreplaceable decorative tile, glass or marble), which may have completely replaced original features. If such retrofit is architecturally important, has significant retail history, or is noteworthy, preserve these features as noted above.
- 4.1.6 Always use the gentlest cleaning methods possible which include simple washing with mild detergent and natural bristle brushes, or specific restoration chemicals if stronger cleaning or paint removal is intended.

Inappropriate

- 4.1.7 Never sandblast or use any abrasive cleaning methods on historic materials. The materials are older and softer and will be permanently and irreversibly damaged. This includes high-pressure water washing unless monitored by a professional historic preservation sensitive contractor using appropriate restoration cleaning chemicals.
- 4.1.8 Do not immediately remove original or historic material if it does not seem to comply with modern building codes. There is a dollar value to saving irreplaceable historic elements if additional alternative code solutions can be made. Historic material is MOST valuable when retained in place. Check with local code official or Planning Staff and ensure that all state recognized measures (potential "code alternatives") are taken to save historic material. (See Appendix IV: "Resources" for assistance).
- 4.1.9 Do not repair or re-point masonry with harder (Portland cement) based mortar or contemporary engineered bricks. These materials will be too hard and rigid for the softer (lime-based mortar) composition of the historic masonry, and will cause permanent irreversible damage to the masonry wall.
- 4.1.10 Do not install brick veneer or siding with "residential" (or smaller frame) windows over or in place of full display storefronts.

Entrances and Plans

- 4.1.11 Preserve (retain and restore rather than replace), or replicate if necessary, any storefront plan (angles, depth, recessed, flush or other).
- 4.1.12 Determine and retain or replicate if necessary the original entry ceiling height, door transoms, materials or placement of doors (right, left or center facing, single, double, etc.) original to the storefront, and/or those changes to entrances that have gained historic significance over time.
- 4.1.13 Determine and retain or replicate if necessary the original entry exterior floor (original hex tile, wood, cast iron sill plate, etc.) original to the storefront, and/or those changes to entry floors (terrazzo, store name plates, artistic tile, mosaic, etc.) that have gained historic significance over time.

Doors**Appropriate**

- 4.1.14 Preserve (retain, restore and maintain) any original entry doors.
- 4.1.15 Retain (and repair) rather than replace deteriorated door parts.
- 4.1.16 If replacement of parts is necessary due to severe deterioration, replace with features to match (accurately duplicate profiles, massing, scale) in design and materials.
- 4.1.17 If original doors cannot be determined using photographs or historic resources, order custom replacement commercial doors. Generally, at least 80% of a commercial style door is glass. Replacement doors should have glazing proportionate to the display window glass, and kickplate panel height is generally not higher than that of the display bulkhead panels. Wood is preferred, however there are good sources for metal doors with colors or bronze anodized finishes that have wide rails and stiles with deeper profiles.
- 4.1.18 Door hardware, if missing on originals or on replacement doors, should be of the same architectural form and style of the storefront.
- 4.1.19 Retain later-period doors that match significant modern styles of storefronts with important retail history or those using quality modern materials.

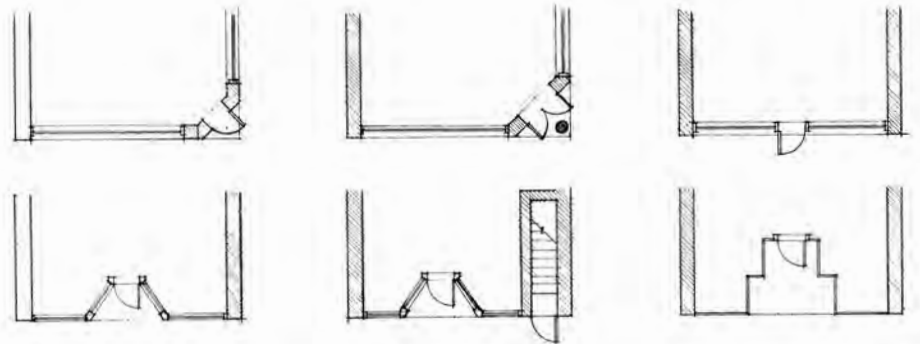
Fig. 2.12: Basic Storefront Plans (25 feet wide storefront)

Not to scale. These are only *sample*, basic storefront configurations.

Inappropriate

- 4.1.20 Residential doors (form and style) are not permitted on storefront entries, as well as "French doors" (those containing multiple divided glass panes).
- 4.1.21 Do not immediately remove valuable original historic doors if they do not comply with modern building codes. Check with local code official or Planning Staff and ensure that all state recognized measures (potential "code alternatives") are taken to save historic material. (See Appendix IV.2: "Preservation Briefs" for resource for retro-fitting storefront doors).

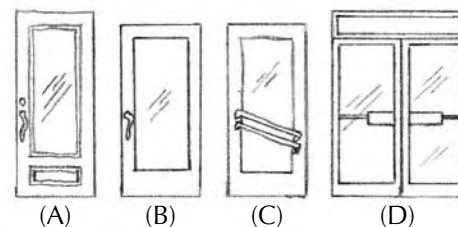
Fig. 2.13: Illustrated Examples of Traditional Commercial Doors**APPROPRIATE:****INAPPROPRIATE:**

Typical (yet not limited to) commercial door examples for: (A) high-style Victorian (may have oval glass or beveled glass), (B) most common door that is simple and versatile for any style storefront, is still used today with full glass, wood construction and high kick-plate, (C) Art Deco or Art Moderne styled handrails, (D) aluminum - not recommended unless displays match (1930s - today).

4.1. Storefronts (continued)

Displays



Conway, 2010

This building makes excellent use of three independent, large double-hung original wood windows (and appropriately curved awnings for the opening shade) as attractive display cases.



Comparison - Display frames in Conway, 2009

Different storefront eras require different maintenance techniques. (A) New glass that may inset into wood casings of one display would not accurately replicate rare 1930s aluminum framing (B). Where original display material is threatened use interior display glass set to rear of the cases.

Fig. 2.14: Features of Storefront Displays



JB+H Photo Archives

Non-cluttered displays and lighting help with visual organization. It is as important to run lights in the day as at night.



Conway, 2009

The geometric layout of mid-20th century displays are significant to retain ca.1930 "Deco" metal frames, display materials, entry doors, stand-alone display case and zig-zag "seamless" glass are important.

Appropriate

- 4.1.22 Preserve (retain, restore and maintain) any original display material. Specifically address integrity of glazing putty, exterior edges of framing reveal or interior stops that secure display glass. These items are exposed to most weathering and UV light and are intended to be maintained.
- 4.1.23 Retain (and repair) rather than replace deteriorated display parts.
- 4.1.24 If replacement of parts is necessary due to severe deterioration, replace sections with features and frame construction to accurately duplicate profiles, reveal, massing and scale in design and materials.
- 4.1.25 If original display parts cannot be determined using photographs or historic resources, install custom replacement display windows. New displays should have glazing, frame width and placement of divisions proportionate to the original displays, coordinated with transom divisions and generally replicated across all storefronts in same building. If metal frames are found as appropriate replacement, there are sources for paintable-aluminum, bronze or anodized finishes that have wide, deeper profiles.
- 4.1.26 Use flexible, clear silicone sealer where the frame meets the glass, or interior "Plexiglas" set behind the display area to cut heat gain and drafts.
- 4.1.27 Retain later-period displays or significant modern storefronts having a retail history to downtown, or those using quality modern materials, to preserve later storefront features as noted above (see also item #4.1.5).

Inappropriate

- 4.1.28 Do not remove, replace, reduce, cover, or alter original display windows.
- 4.1.29 Do not sandblast or use any abrasive method to clean or strip, including high-pressure water. Use only gentle, restoration-sensitive chemical cleaners and strippers or mild detergents and natural bristle brushes (see also Section B, Chapter 4.4. "Exterior Walls").
- 4.1.30 Do not install smoked, mirrored, or tinted window glass or films. This severely limits valuable product display capability reflecting the street scene back to the pedestrian and has an inappropriate character for the traditional environment. Gain shade with deep enough awnings and/or canopies and keep display lights on during the day.
- 4.1.31 Do not install thick insulated glass if original, historic frames, trim work and display configuration do not accommodate the new glass. Contemporary glass can be ordered and often set into traditional wood framing with the same trim and stops re-installed to the new glass thickness. Historic metal frames are more difficult due to the precise fit of parts.
- 4.1.32 The removal of historic glass or displays should not be carried out due to simple drafts that can be addressed with proper maintenance. An enclosed storefront is not a trade off for a well placed, extended awning or traditional interior sun-screening device. If possible, use sun-screening and new glazing in tandem for the best efficiency.

Transom Windows

jB+ Photo Archives: Inside looking outward.

Transom windows below the awning are common if storefront opening is low. Light-weight fabric allows translucent light to reflect off stamped or light-color ceilings.



jB+ Photo Archives

Keep in mind what the transom windows look like from inside looking out and at night as well as day. Unique or historic display lighting can be a marketing tool.



jB+ Photo Archives

Wood framed transoms (with equally spaced vertical mullion divisions) are a traditional transom element used just above displays that follow the original recessed storefront arrangement.

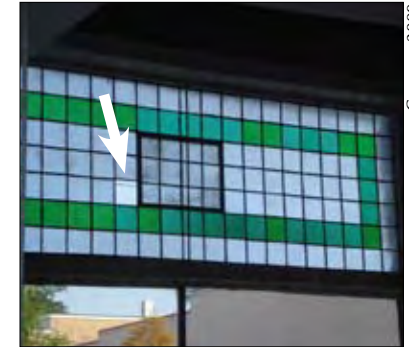

Conway, 2009

Decorative mullions or leaded prism glass transoms are a common and distinctive early 20th-century solution to diffuse light. These transoms can warp over time and a stained glass professional is needed. Missing pieces can be filled with close colors.

Appropriate:

- 4.1.33 Preserve (retain, restore and maintain) original transom windows.
- 4.1.34 Retain (and repair) rather than replace deteriorated window parts.
- 4.1.35 If replacement parts are necessary due to severe deterioration, replace with features to match (accurately duplicate profiles, massing, scale) in design and materials. Hardware should be of the same architectural form and style as that of the transom window.
- 4.1.36 Use interior storm windows and caulk open casement joints as weather sealing, while preserving original windows and profiles from the exterior.
- 4.1.37 Use operable, wide-slat interior blinds or shades in transom areas to keep sunlight from damaging merchandise and reduce glare on patrons.
- 4.1.38 Transom windows were often removed for modern steel beams to carry the structure above "modernized" glass storefronts or to install rigid canopies. Assess if transom windows can be rebuilt or the past major alterations can be covered. Paint covered transom areas dark gray with attached framing painted to match displays to visually replicate.
- 4.1.39 Exterior awnings can shade transoms or be used to cover unfinished transom area from public view (see Section B, Chapter 4.4, "Awnings").
- 4.1.40 Retain later-period transom windows that match significant modern styles of storefronts with important retail history or those using quality modern materials.

- 4.1.41 If original transoms cannot be determined using photographic or physical evidence, then provide custom replacement framing compatible with the architecture (and windows) of the building. Generally, custom replacement windows should have glazing that is proportionate to the transom window opening, and mullions of the transom should be true-divided glass panes. Wood is preferred.

Inappropriate:

- 4.1.42 Do not replace historic transom windows with off-the-shelf replacements. Standard-sized stock replacement windows often do not fit historic openings. Further, this size difference would require in-fill casing, which is an inappropriate treatment in the historic district.
- 4.1.43 Do not replace historic transom windows as a solution to a perceived moisture problem. Moisture and condensation that appear on single-pane glass is normal from time to time in changing weather. One potential source of moisture is the wall system or interior atmosphere, which replacement windows will not mitigate.
- 4.1.44 Avoid vinyl, plastic, or fiberglass parts as these are not of a historic nature and degrade quickly in UV light.
- 4.1.45 **Grid-between-glass, flat snap-in vinyl mullions are not allowed.**

4.1. Storefronts (continued)

Bulkheads



JB+a Photo archives, 2008

Wood, inset panel bead board bulkheads and sills are appropriate for Victorian era storefronts. Many have been lost as storefronts changed. Note cast iron column.



JB+a Photo archives, 2008

Wood bulkheads were later built to carry brass, copper and later aluminum displays. This method of construction is still appropriate for new construction.

Fig. 2.16: Features of Storefront Bulkheads



Both Images Conway, 2009

(Left) Brick bulkheads with header course sills, are common with wood or metal display frames. (Right) Other buildings in the civic district near courthouse have no display windows, brick or landscaped areas.



Conway, 2009

Low, mid 20th-century and contemporary storefronts use a variety of veneer materials such as marble, polished granite, cast stone, pigmented glass, or tile. Later these may be full plate glass with no bulkheads at all.

Appropriate

- 4.1.46 Preserve (retain, restore and maintain) original bulkhead material, especially maintaining the integrity of mitered trim work, profiled framing, or wood craftsmanship that might experience wear below the display windows. Bulkhead areas are prone to deteriorate more quickly than other areas of the storefront as they are exposed to weathering.
- 4.1.47 Retain (and repair) rather than replace deteriorated bulkhead parts.
- 4.1.48 If replacement parts are necessary due to severe deterioration, replace with features to match (accurately duplicate profiles, massing, scale) the storefront in design and materials.
- 4.1.49 Wood is the most traditional material for the bulkhead area, with wide framing and thick display sills for more "pedestrian" use. Look for wide areas of raised or inset wood panels (smooth or bead-board).
- 4.1.50 If original bulkhead areas are brick they will probably match that of the building piers and upper facade, often with angled brick sills supporting wood framed displays. Stucco, tiles or brick veneers are other types of masonry that might have been applied over original framed bulkheads in later styles of architecture. Study bulkhead materials.
- 4.1.51 All framing must be paint-grade and primed. Fiberglass reinforced plastic (FRP), exterior-grade bead-board panels, exterior-grade plywood, and contemporary polystyrene trim can be used only if replacing or rebuilding wood trim and/or bulkheads.

- 4.1.52 If original bulkheads cannot be determined using photographic or physical evidence, then provide custom replacement framing compatible with the architecture of the building. Replacement bulkheads should be in keeping with similar structures in the adjacent downtown area. Old paint lines or "shadow lines" on original storefront framing may be found to determine original bulkhead profiles. Customize bulkhead panels and sill height proportionate to the size of the storefront opening. (Generally bulkheads are no more than 2 1/2 feet high; about knee-height or less.)
- 4.1.53 Retain later-period bulkheads that match significant modern styles of storefronts with important retail history or that use quality modern materials.

Inappropriate

- 4.1.54 Do not remove, replace, reduce, cover or alter any original display bulkheads and avoid too many colors that will detract from displays.
- 4.1.55 Residential veneers and siding materials are not allowed as a bulkhead covering.
- 4.1.56 Do not cover bulkhead framing or areas with spray on polystyrene, spray vinyl, "blown-on" coatings, built-up mesh trim, or exterior insulation and finish systems (EIFS) materials.

Store Cornices/Beltcourses/Sign Band



Conway, 2009



Conway, 2009

“Banding” of traditional building materials (masonry or applied) aligns with cornices or window openings, as well as across facades.

Cornices and materials should delineate frames of storefronts. Exposed beams on may be part of some storefronts (top) or brick “sign” bands on others (bottom).

Appropriate

- 4.1.57 Preserve (retain, restore and maintain) any original horizontal dividing or decorative elements to the facade. In general these may be, but are not limited to, corbelled masonry courses, stone sills, and appliqué trim that define the horizontal division of the facade.
- 4.1.58 If the store cornice or sign band area is earmarked by an attached feature that caps or frames the storefront area, often with like-material of the upper cornice on a smaller scale, or if evidence shows this existed, restore or rebuild this feature.
- 4.1.59 If replacing a missing beltcourse, closely match or imitate the original type in general design, location, materials, detailing, and scale.

(See also Section B, Chapter 4.2 “Upper Facades - Building Cornices” for more guidelines.)

Fig. 2.17: Features of Storefront Cornices and Banding



JB-ra Photo archives, 2008

Simple storefront cornices (or mid-to late-20th-century drip caps) give a horizontal and stylized element. This may also conceal an extendable awning.



Conway, 2009

Mid-20th century historic architecture expresses horizontality in subtle details, patterns and engineered materials. Often cornices are reduced or eliminated.

Inappropriate

- 4.1.60 Spray-on polystyrene, “blown-on” coatings, built-up mesh, or exterior insulation and finish systems (EIFS) materials are not be used to replace, rebuild, or simulate a historic cornice. These materials do not have the sharpness of the stamped details of metal or fiberglass reinforced plastic (FRP) cornices.
- 4.1.61 Do not remove or add your own course-work (banding, trim, cornices, etc.) that was not intended for the period of architecture, by the original building design. Use historic photographs to prove details before they are falsely subjected.

Fig. 2.18: Cornice Construction

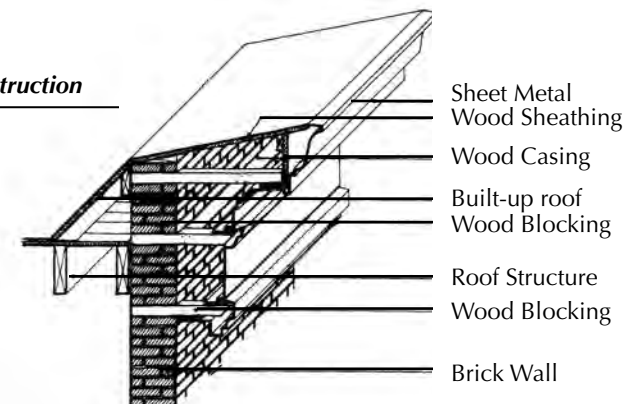

4.2. Upper Facades

Upper Windows



Upper windows are usually custom fit, large and have thick reveal due to the scale of facades. Using proper upper facade windows creates added pattern.



Upper windows custom designed with architectural facade styles in mind (note horizontal banded windows and cast concrete frames are important to the "International Style" (ca.1945)



If upper windows on rears of buildings, mid-to-late-20th century buildings, or industrial buildings are constructed of steel mullions. Use rust-bonding primers, re-glaze and paint to retain these character defining features.



The oldest wood windows are especially salvageable. Fully rotted pieces should be rebuilt and older-growth hardwood can be oiled, primed, and painted. Covered windows may be found on upper floors.

Appropriate

- 4.2.1 Preserve (retain, restore and maintain) original upper-story windows.
- 4.2.2 Wood is the most traditional window material, however dependent upon the age and style of the building (and location of the windows) steel, aluminum, glass block and other materials may have been used from different eras. Research materials from the era of your building.
- 4.2.3 Retain (and repair) rather than replace deteriorated window parts.
- 4.2.4 Assess the mechanics of each window and repair as needed. If replacement of parts is necessary due to severe deterioration, repair with pieces to match (accurately duplicate profiles, massing, scale) in design and materials. (See item #4.2.7 for weather sealing.)
- 4.2.5 **If original windows cannot be determined using photographic or physical evidence, then provide custom replacements that are compatible with the architecture of the building.** Replacement windows should have glazing proportionate to the opening with mullions (generally deeper profiles) that divide windows in panes per sash. Surfaces should be paintable.
- 4.2.6 If sash weights and weight pockets still exist, these historic features should be retained, rebalanced or repaired. If these pockets are no longer used, insulate with fiberglass batting, which is reversible (do not fill with expanding-foam). Some historic windows have been retrofitted with aluminum compression channels rather than sash

weights or have had these installed over the years; assess their integrity to potentially restore the weights. Use chain, wire, nylon, or natural rope that will not degrade in UV light to replace cords.

- 4.2.7 For appropriate weather seal (wood or metal windows) use weather stripping or route flexible weather stripping into wood sash styles. Caulk open casement joints and spaces around aprons. Use interior storm windows for ease of maintenance from upper floors and historic profile appearance from street.

Inappropriate

- 4.2.8 Avoid replacing historic windows with off-the-shelf replacements or new windows that do not equally fit the original framed opening.
- 4.2.9 Avoid vinyl, plastic or fiberglass parts as these are not of a historic nature and degrade quickly in UV light.
- 4.2.10 Grid-between-glass or "snap-in" flat vinyl mullions are not allowed.
- 4.2.11 Do not discard historic original windows immediately because of condensation or air. Moisture and condensation occurs on single-pane glass when the source of moisture is often from ground water infiltration into the wall system, crawl spaces without moisture barriers, lack of insulation or general interior atmosphere. Leaking windows are often from other unsealed areas of the building. Use dehumidifiers if needed.

Upper Building Cornices



Conway, SC 2009

Early decorative cornices on some of the oldest buildings in downtown involved simple to sophisticated masonry techniques.

Appropriate

- 4.2.12 Preserve (retain, restore and maintain) original metal or brick cornices. (This also includes matching materials over windows called “hoods.”)
- 4.2.13 Retain (and repair) rather than replace deteriorated cornice parts.
- 4.2.14 If replacing or repairing brick, make sure that the characteristics of any new brick match that of the old (size, shape, porosity, surface finish), not only for the cornice style but also to relate with the shrinking and swelling of the entire historic masonry system. (See Appendix IV.2. “Preservation Briefs” for information.)
- 4.2.15 Assess the stability of the cornice mounting system. Generally this was wood frame set into masonry pockets across the top front of the facade. If deteriorating, and the cornice is original or historically significant, it must be removed carefully and returned with a new bracket system.
- 4.2.16 If replacement of visible parts (generally, parts seen from the street or sidewalk) is necessary due to severe deterioration, replace with features to match (accurately duplicate profiles, massing, scale) in design and materials.
- 4.2.17 **If original cornices cannot be determined using photographic or physical evidence, then provide custom replacements that are compatible with the architecture of the building.** This pertains to the size of the facade and the style of the building. Replacement cornices should be in keeping with similar structures in the adjacent downtown area.



Conway, SC 2010

Background parapet wall gives the illusion of a taller building aligning with decorative brick cornice around the block on **National Register Downtown Historic District** buildings. This was often in anticipation of future, taller buildings.

Fig. 2.20: Features of Upper Building Cornices



Both Images, Conway, SC 2010

Terra Cotta cornices can be found in different forms. Unique 1910s facades on Main St. have built-in Craftsman inspired tile cornices (note the proper alignment of neighboring 1970s cornice, top), and parapet wall caps (bottom).



Both Images, Conway, SC 2010

Warehouses in the **Riverfront HDRD that from the Commercial HDRD** have simple, stepped brick, tile capped cornices (top). A small structure off 3rd Ave. is entirely glazed brick with rounded corners as the cornice (bottom).

- 4.2.18 Metal is most traditional for stamped cornice material, still available from specialty metal fabricators today, however excellent reproduction and precise duplicate cornices can be ordered in fiberglass reinforced plastic (FRP) designed to endure the harsh weathering conditions upon the upper sections of the facade.

Inappropriate

- 4.2.19 Do not use spray-on polystyrene, spray vinyl, “blown-on” coatings, built-up mesh, or exterior insulation and finish systems (EIFS) materials to replace, rebuild, or simulate a historic cornice. These materials typically are out of scale, have rough surfaces, and do not age or weather well. In addition, they do not have the sharp details of the stamped systems of cornices.
- 4.2.20 Do not repair or re-point masonry with harder-based mortar (Portland cement) or contemporary engineered bricks. These materials will be too hard and rigid for the softer, lime-based mortar composition of the historic masonry and will cause permanent, irreversible damage to the masonry cornice system.

4.2. Upper Facades (continued)

Commercial Roofs

The general rule for roofs is to assess what is seen from the vantage point of the pedestrian. The basic form of the roof system (flat, pitched, gabled, arched, etc.) and the materials such as standing metal seam, various shingles, etc., if seen by the pedestrian, should be maintained. Most of Conway's downtown historic commercial buildings have flat or gently sloping roofs with rolled composition or asphalt materials and masonry parapet wall systems. **Parapets provide general visual coverage from the pedestrian and allow the building owner possibilities to repair or replace the roof with no historic detriment. However, adding extra roofs, especially seen from the street (Fig. 2.21), is inappropriate.**

(right) A well maintained flat commercial roof with good pitch to rear. Note applied roof membrane continues up back side of parapet walls to clay coping tiles that protect the wall tops. Roof in background has a skylight "monitor."



jB-ra Photo Archives

1. Roofing Material

Appropriate

- 4.2.21 Preserve original roof forms (joists and rafters) where they exist.
- 4.2.22 New roofs of like-covering or similar materials are appropriate. Modern roof covering systems (generally for flat roofs) provide a range of contemporary and heat-reflecting options that are appropriate for historic buildings, which will protect the building.
- 4.2.23 The installation of a higher pitched roof to "improve" water runoff may be appropriate ONLY if it can be proven that the existing system is incorrectly installed or if new materials cannot improve the efficiency of the roof. If a new pitched roof is installed, the new roof line must not be visible on the primary facade and must be constructed below the original roof parapet wall.

Inappropriate

- 4.2.24 Do not install any form of "shed" roof over the existing roof (Fig. 2.21).
- 4.2.25 Do not install a higher pitched roof that can be seen over the parapet walls or from the public street level.

Fig. 2.21: Coverings and New Roofs

APPROPRIATE:

(Original)



INAPPROPRIATE:

(A)

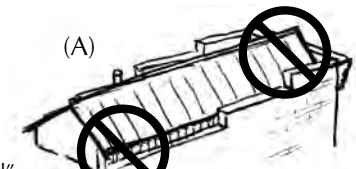

(B)

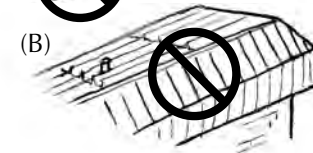

In the inappropriate examples (right), "shed" roofs are (A) installed on top of the original, visible over the parapet walls from the side view and the front cornice, as well as diverting water onto side buildings rather than directly back. and (B) a full metal encasement roof changes the entire form and style of the building.

(Right) Stepped parapet walls cover the rounded warehouse roofs in the Riverfront HDRD (also see Section E "Waccamaw Riverfront HDRD.").

2. Parapet Walls

Appropriate

- 4.2.26 Preserve original parapet walls where they exist.
- 4.2.27 Use copper, applied membranes or modern flashing along brick parapet walls to avoid leaks where they meet the roof. Older buildings expand and contract greatly. This entire system should be installed to be flexible, with caulk and sheets of material that are not applied too rigidly to the parapet wall.

Inappropriate

- 4.2.28 Original parapet walls and features should not be altered, painted or removed (such as decorative brick work, terra cotta coping, cornice tie-in or original shed or mansard roofs).
- 4.2.29 Do not repair or re-point masonry with harder-based mortar (Portland cement) or contemporary engineered bricks. These materials will be too hard and rigid for the softer, lime-based mortar composition of the historic masonry and will cause permanent, irreversible damage to the masonry parapet wall system.
- 4.2.30 Do not install a "shed" system to cover or overlap parapet walls.



Conway, SC 2010

B COMMERCIAL HDRD HISTORIC DESIGN GUIDELINES

Chapter 4 COMMERCIAL REHAB & ARCHITECTURAL DESIGN GUIDELINES

4.3. Rear "Facades"

Although the rear elevation of buildings is traditionally service-oriented in design, having less adornment than the front facade of the building, they contribute to a building's history and the overall downtown character. The rear of the building may be more visible to the public than a building owner realizes, making it just as important to address maintenance of the elements and the surrounding outdoor area.

Retain Context of the Rear Elevation

Often, with marketing and maintenance, the rear of the building can be a "second face" for the businesses within. Rear areas and alleys have the potential to be very interesting extensions of the business space if the utilitarian character of the rear facade is retained.

Appropriate

- 4.3.1 Preserve the historic integrity of the rear building environment by maintaining and re-pointing existing softer mortar or masonry with like (usually higher lime content) mortar.
- 4.3.2 Preserve the "service-oriented" character of the rear facade when replacing hardware or elements. Use simpler materials than those used in the front public facade. Doors, loading platforms, windows (often steel mullions with wire-glass or even burglar bars), stairs, gutters, lesser-quality brick, and exposed foundation materials would traditionally not have been adorned with the same decorative treatments as the front facade.
- 4.3.3 Use service or "shop-style" reproduction lights and sconces that are bright enough for security purposes.
- 4.3.4 The original intent of the window character should be restored or re-built. Preserve the sashes and mullions of the rear facade windows (steel or wood). Frosted glass can be used if privacy is desired.
- 4.3.5 Maintain safety for the business while reducing the visual detraction and "unsafe" perception of security bars. Burglar window films or interior (visibly) mounted burglar bars with audible, wireless alarm systems, and/or permanently installed interior (insulating) storm windows will improve safety, energy efficiency, and exterior aesthetics (perception).

Fig. 2.22: Components of the Rear Elevation

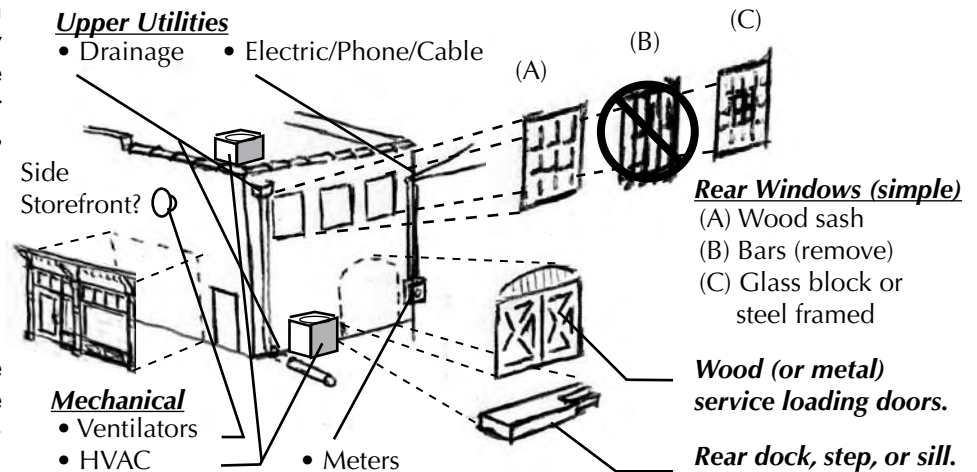

Inappropriate

- 4.3.6 Do not sandblast rear facades as a cleaning method, nor use any abrasive cleaning method, including high water pressure washing. This is all too abrasive for softer, historic materials.
- 4.3.7 Do not paint natural brick (or use brick hues if re-painting.)
- 4.3.8 It is tempting to use lesser quality maintenance materials on the rear of a buildings. Do not use harder (usually Portland cement-based) mortar than the existing mortar in the joints of the rear facade. Using dissimilar materials on a historic building, which has natural movement, will ultimately and irreversibly damage the building.



Rear areas in Conway are clean and have good delineation of parking and services.



Rear elevations are good for alternative ADA access to shops. Direct with signs from front and use an awning for a comfortable entry. .

Rear Utilities

Appropriate

- 4.3.9 Screen utilities and dumpsters with plantings or well-vented brick or wood screen walls.
- 4.3.10 Remove old mechanical equipment, service lines, HVAC and pipes. Move building services into one area if possible. Simple paint can be effective if items cannot be removed.
- 4.3.11 If possible, combine dumpster usage between multiple businesses in common dumpster "corrals" in the rear areas of alleys or properties. Ensure common dumpster areas are screened with landscaping if they face any public streets.
- 4.3.12 Ensure grease traps and disposal from restaurants are located for disposal professionals' easy access on a routine basis. Some sites are finding in-ground tanks to be useful. Ensure stand-alone grease collection is ventilated to prevent heat and odor build-up.
- 4.3.13 Repair broken down spouts, collection "scuppers," rusted in-ground drain pipes and gutters. These items, together with cracked asphalt

alleys and foundations in need of repair can direct detrimental moisture into the masonry.

- 4.3.14 Ensure ground surface is graded away from the building foundation. Installing "French drains" (see Appendix IV.4) can help direct water away through permeable ground around a building. Always gain permission to divert run-off to lower areas or public street gutters.

Fig. 2.23: Rear Features Before and After Retain Context

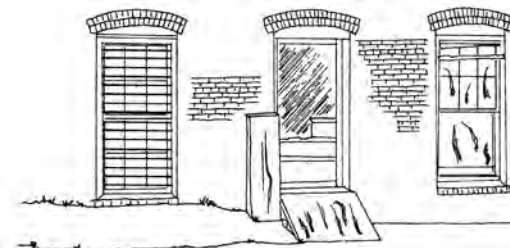

BEFORE

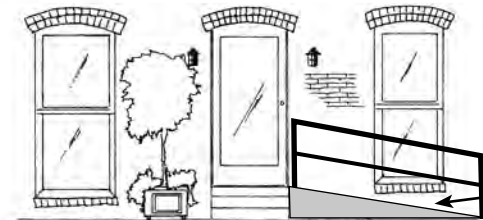

AFTER

NOTE: Rear facade (shown) is most likely off of a paved alley. Planters may be used where there is no public streetscape. The context of the service component is retained with a ramp, new basic sash windows and glass door. (Image used from GA Dept. of Community Affairs.)

Modify Loading Ramp / ADA Feature

Back Entrances & Loading Areas

If the rear of a building is used as a second entrance, it is important to preserve the integrity and aesthetic of the traditional service character.

Appropriate

- 4.3.15 Retain and repair rather than replace original loading doors. (Large original service or fire doors can be secured open to preserve their presence with new, contemporary doors installed just inside the opening. Sometimes large service entries have enough room to incorporate a common vestibule having multiple internal entries to businesses and collected services such as gas or electric meters.)
- 4.3.16 Metal service doors are acceptable with or without glass, depending on the level of security, however a good coat of paint goes a long way in addressing the stark nature of a gray metal door.
- 4.3.17 Canopies or awnings are acceptable if patrons will be using the rear entrances or if upper floors are used for business or as a residence. Awnings on rear windows serve the same protection

as those on fronts. Use simple design, such as straight edge valances rather than decorative scallops and solid colors rather than stripes.

- 4.3.18 Service entries are better served with simple rigid aluminum canopies if there will be deliveries, trucks, or movement of supplies and personnel that might damage a fabric awning easily.

Inappropriate

- 4.3.19 Do not impose false, "Main Street" style storefronts to the rear of the building.
- 4.3.20 Do not use residential-style doors for rear entrances.

4.4. Additional Features and Amenities

Beyond the composition of the storefront, a building's complete exterior defines its architectural style. There are both intrinsic physics and finish details that contribute to a building's appearance and function. Changing features and amenities often or with each business, are subject to review by the Community Appearance Board to ensure commonly misunderstood items respect the historic resource.

Exterior Walls

The exterior envelope is the greatest mechanical system of a historic building. Soft, early 20th century and hand packed brick earlier than 1900 react to moisture and temperatures with expansion and contraction. Buildings built before air conditioning need air space within the walls for insulation as well as vapor transmission for the building. Soft material such as lime and sand mortar is intentional and necessary for conditions. It will be damaged quickly by moisture "wicking" upwards in the wall system. Known as "rising damp," this phenomenon is worsened by later applications of stucco, multiple coats of latex paint on exterior walls and modern brick sealers (and can be intensified on walls that have had their interior plaster inappropriately removed.)

NOTE: If the interior walls are showing wear and damage, look for exterior causes first. Water infiltration caused by improper exterior work, "rising damp" from high water tables, damp foundations or structural stress from other areas on the wall are common and can be remedied (See image above & Appendix IV.2, NPS Preservation Brief #2 for additional guidance.)

Appropriate

- 4.4.1 Ensure no water infiltrates the walls through diversion and that (above and below ground) water is kept away from foundation.
- 4.4.2 If the exterior surface is painted, and the paint layer on the substrate is stable, repainting the exterior is appropriate. Chemically removing paint rather than adding new paint is preferred, as it benefits the health and original appearance of the brick. A simple color scheme is recommended, generally no more than four colors. Neutral, brick or earth tone hues are recommended for the building surface, with the cornices and framing incorporating colors that match or compliment the dominant neutral building material.
- 4.4.3 **Older masonry should be repointed every 40-75 yrs. (depending on facade elevation and weather conditions) with "like" mortar to original.**

Older buildings have softer historic brick and mortar. After nearly 100 years this can become weathered. DO NOT repair with harder, Portland cement mortar.

Soft mortar MUST be replaced with "like" soft, lime-based mortar to avoid permanently destroying the integrity of the historic brick.



jB+a Photo Archives

Inappropriate

- 4.4.4 Do not paint unpainted masonry surfaces or add water sealers or apply clear coating of any kind to the masonry. These will change the vapor transmission of the wall system, irreversibly and permanently.
 - 4.4.5 **Do not sandblast or use any form of abrasive cleaning method (including high-pressure water). This is highly detrimental to older walls.** Use chemical strippers and cleaners formulated for the soft historic material that will not break the outer "crust" of old brick or patina on stone.
 - 4.4.6 **Do not repair or re-point masonry with harder (Portland cement)-based mortar or contemporary engineered bricks.** These materials are too hard and rigid for the softer (lime-based mortar) composition of the historic masonry, and will cause permanent irreversible damage to the masonry wall.
 - 4.4.7 Do not uncover a past problem. **Some exterior surfaces may have had covering or application of veneers or stucco for viable maintenance reasons long ago such as poor masonry, a fire which compromised the brick or a natural disaster.** Research the building history if a facade covering or veneer exists.
- (note) While the CAB does not have jurisdiction over interiors, please note that Improper interior treatment of walls can easily compromise the entire wall system through to the exterior. Do not remove interior plaster to expose brick walls. Historic brick is soft, especially if intended for plaster to adhere. Exposing and covering with water sealer will not solve conditions of crumbling or sandy mortar; these actions will add an additional moisture-causing problem. If original plaster is cracking and must be removed, install furring strips and attach sheetrock to gain the appropriate "finished" interior appearance of the historic environment or leave "patina" surface as is.

4.4. Features and Amenities (continued)

Quality Architectural Materials

The tradition of using the highest quality materials for the public faces of any commercial facade or storefront should be continued today. Wood in windows, framing, or storefronts from 80 to over 100 years ago can be re-conditioned (even when it seems the driest or “grayed”) because it is of higher quality than today’s lumber. Historic materials are highly flexible and resilient to change, which has allowed them to last.

(For more information on exact procedures for care and maintenance of historic materials see Appendix IV “Routine Maintenance” - specifically National Park Service *Preservation Briefs* list of materials and subjects.)

Appropriate

- 4.4.8 Have respect for and work with historic materials by learning about them before removing (See Appendix IV.2 for guidance).
- 4.4.9 Cast iron or metal components are very important features. Paint may be removed from any surface with the appropriate restoration chemical agents; use the most sensitive possible. Run test patches of solvents (sandblasting or abrasive cleaning is discouraged). Steel will rust, ensure proper primers are applied first or use oil-based products; latex is inherently water-based and may promote rust.
- 4.4.10 Ensure metal-to-metal contact is the correct combination. Metals will degrade or corrode if the wrong polarity of different metals is used to fasten or attach other elements.
- 4.4.11 Identify stone surfaces such as granite, and differentiate them from marble or stucco veneers. These materials will require entirely different chemical cleaners and methods used to attach items. Substrates could be affected by surface treatments such as rust stains from stone crimps or stucco lathe pulled through porous masonry surfaces.
- 4.4.12 Assess all eras of remodeling. Approach rehabilitation to preserve the period and materials which are most in-tact and have the greatest significance (Section A, Chapter 1.7 “Recognize Change”). For example, during the era of “streamlining” buildings from the 1920s to the 1940s, some materials such as pigmented structural glass, tiles, or laminates are now obsolete and have become very valuable. Some retrofitting was not sensitive to the original structure, but some was needed (see #4.4.7). Study the integrity of original materials beneath and assess the attachment systems to which covering was applied.

Fig. 2.24: Study of Architectural Masonry Found in Conway

With a focus on masonry alone Conway downtown is full of quality resources. Less expensive cover-up materials have come down over recent decades and there are many eras of materials to preserve. Continue new construction with materials that are lasting.

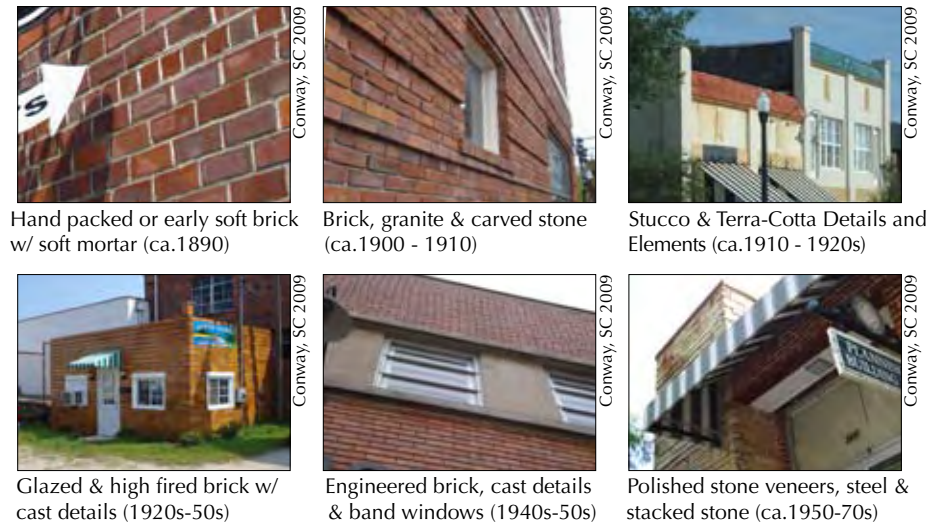

Inappropriate

- 4.4.13 **Do not impose modern materials or “quick fixes” that cover-up maintenance**. Exterior brick must be repointed (see #4.4.3-4.4.7), wood must be painted (more or less depending on weather exposure.) Stucco and synthetic coverings will not stop deterioration and usually accelerate it. Attaching materials has the potential to create permanent building damage. New materials not originally intended for any older construction may create permanent damage to the building.
- 4.4.14 Do not remove defining materials from later periods of history that may be part of the facade, such as retrofitted storefronts or facades which have historically significant materials in their own right.

Awnings and Canopies

Awnings, properly installed and scaled (Figure 2.25), can be an important stylistic and functional element of a building facade. They provide protection from the weather and from UV sunlight that can harm display merchandise, and they greatly reduce the amount of maintenance to the storefront area. Most historic buildings have had, or were designed to accommodate, awnings or canopies of some sort. Keep display lights on in the daytime.

Awnings can be rigid canopies in the form of built-in “ledges” consistent with the architectural style of the building (Art Deco, Art Moderne or International styles). These are lightweight aluminum or sheet metal attachments, often used to replace fabric awnings as storefronts changed in style.

The traditional installation of an awning is determined by a combination of the following factors: the direction the storefront faces, the style and period of the intended facade or storefront, and the amount of open area above the display available to affix an awning. Transom windows might be located above or beneath the mounted height of any awning. Northern-facing storefronts had higher transoms to bring in light, or often designed without awnings and use of recessed entries to shield patrons from rain. East- and west-facing facades might have had retractable awnings used as needed at different times of day or year. Storefronts facing south may have the deepest projecting or largest awnings.

(Continued on next page.)



Conway Bus Station Bldg. & JB+J Photo Archives

(Top) Contemporary retractable awnings with side-less construction have traditional scale & open to light transoms. (Bottom) A curved awning creates continuous design element over a corner Art Deco display.



Conway, SC, 2009

Deep projecting awnings are appropriate for the comfort of shoppers and product display. Awnings appropriately fit to the outer edge of storefront openings do not “cut” across building piers or other stores.



Brunswick, GA, 2008

Upper awnings are appropriate in coastal areas. Deep projection and set over approx. half the height of an upper window will help cut heat gain and protect the windows from elements.



Conway, SC, 2009

Very few rigid canopies are appropriate in Conway. Yet, this simple, possibly original, aluminum awning remains in good condition, unique, and appropriate to the 1940s bldg. Repair and retain this detail.

Fig. 2.25: Traditional Placement of the Storefront Awning

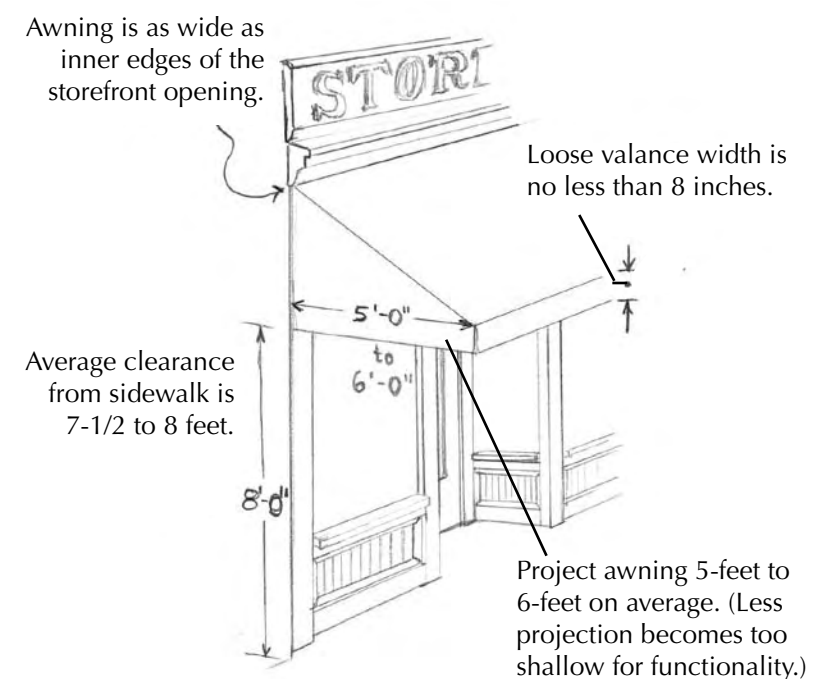

Original image included with permission from Georgia Dept. of Community Affairs, Office of Downtown Development.

4.4. Features and Amenities - Awnings (continued)

Appropriate

- 4.4.15 Preserve (retain, restore and maintain) any original awning hardware if in good condition, original, and/or not a detriment to safety.
- 4.4.16 Retain (and repair) rather than replace deteriorated canopy parts if they are part of the original to the style and construction of building.
- 4.4.17 If replacement of parts are necessary due to severe deterioration, replace with features to match (accurately duplicate profiles, massing, scale) in design and materials.
- 4.4.18 If original awning placement cannot be determined using photographs or historic resources, use custom new hardware. The characteristics of new awning(s) should match that of the traditional (size, shape, width, projection, height) so that it complements the storefront style. The design of replacement awnings or canopies should be in keeping with similar structures in the adjacent downtown area.
- 4.4.19 Fabric is the most traditional material for use with replacement awnings, and the tightest fit will endure the best weathering. Square aluminum frames with crimped-channel fasteners along the entire length of the frame are appropriate.
- 4.4.20 Allow awnings to be an expression of the business. Stripe or solid fabrics will make different statements about the type of business. Some buildings with multiple businesses can choose a "fabric family" of similar stripes, while changing the colors for each storefront.
- 4.4.21 Install loose fabric valances – scallop, straight edge, wave, key or decorative trim give greater individuality to any storefront.
- 4.4.22 Conform the shape of the awning to the shape of the opening (see Fig. 2.26).
- 4.4.23 Awning and canopy frames are traditionally the width of the storefront opening. In some cases with modern architecture there are little or no building piers. Glass storefronts are designed to the edges of (banded around) the facade and canopies may run this length.
- 4.4.24 For rigid canopies assess the stability of the mounting system. Those retrofitted onto older structures in the mid-20th century may have a steel header across the storefront display (often removing display transoms) for cantilevered support where old storefronts were replaced for full-glass fronts. These may require substantial expense to remove and should be studied for load-bearing integrity. Retain the canopy or re-design to the most significant storefront architecture. Assess water diversion from rigid canopies.

Inappropriate

- 4.4.25 Generally, do not install an awning that crosses the entire width of the building from edge to edge.
- 4.4.26 Do not horizontally cover major structural piers or significant vertical storefront elements such as cast iron columns. Breaks in the awning frames lessen the potential for an awning to visually dominate the facade and ease the cost of repair if needed.
- 4.4.27 "Half-dome" shaped awnings are not appropriate for storefronts and upper windows unless the shape of the opening is a true Roman-arch.
- 4.4.28 Avoid use of duplicate patterns or colors that match neighboring storefronts.
- 4.4.29 Do not use plastic or vinyl covering (or are intended for back-illumination) as these have a non-traditional glossy appearance and are often prone to UV damage and color fade.
- 4.4.30 Do not use "quarter-barrel" shaped awnings as they receive uneven sun exposure and often encounter water or stains on the top, flat surface.
- 4.4.31 Avoid plastic clips, nylon cord and thin round aluminum round frames which have proven over time not to be durable materials for the stresses awnings encounter.

Fig. 2.26: Fitting the Awning to the Window Opening

Note: Many older window openings contain an arch. There is more than one way to conform an awning to a segmental-arch window opening, however only one proper fit for a half-dome awning on a Roman-arch window. Scallop or straight valance, with or without side panels is an owner's choice. All are fit ONLY as wide as opening.

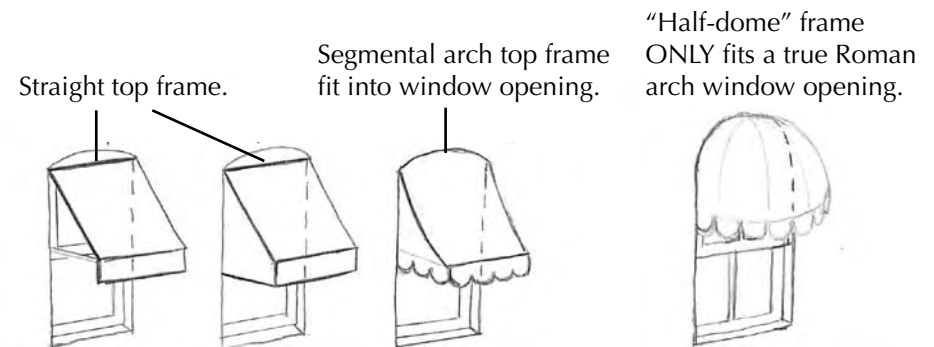

Original image included with permission from Georgia Dept. of Community Affairs, Office of Downtown Development.

B COMMERCIAL HDRD HISTORIC DESIGN GUIDELINES

Chapter 4 COMMERCIAL REHAB & ARCHITECTURAL DESIGN GUIDELINES

4.5. New Commercial Construction

New, in-fill development or new construction to replace a structure that has been lost should continue the dense, pedestrian oriented, urban environment described in Section B, Chapter 3.4 "The Downtown Environment." **To ensure compatible building design in the commercial areas of the Conway Historic Design Review Districts, all new construction must follow all of Section B, Chapter 4 "Commercial Architectural Guidelines" as well.**

Placement and Orientation

- 4.5.1 Align new construction with the setback and spacing of existing structures in the adjacent downtown area, which generally have "zero-lot-line" front or side setbacks.
- 4.5.2 Locate parking to the rear of the building or utilize available on-street spaces.

Scale

- 4.5.4 Design the new construction to be of similar height, width and proportions of existing structures in the adjacent downtown area (see Figure 2.27 right). The CBD has a "party-wall" precedent.
- 4.5.5 Limit the number of stories of new construction scaled to adjacent structures (see also Section B, Chapter 3.4, Fig. 2.7). Generally, no greater than one story higher than the tallest adjacent building. **The CAB has the right to allow variances or deny additional stories if the building appears out of scale with building forms in the surrounding block.**

Style

- 4.5.6 New buildings should be contemporary. It is appropriate to display the style and construction methods of the period in which it is constructed and not become a "faux" reproduction or create "false history."
- 4.5.7 Customize the elements of new construction (material choices, banding, cornices, door types, reveal of materials) in context with those features of existing structures in the adjacent downtown area.

In this commercial historic district a new structure (left side of courtyard) was appropriately designed with facade, storefront, form, orientation, scale and contextual style to the surrounding buildings. Historic one-part building form in the area establish a building form. The new structure was built with all contemporary materials.



- 4.5.3 Window size, placement, as well as storefront opening and height should be consistent with the rhythm of those in existing building forms in the adjacent downtown area (see Figure 2.28 below).

Fig. 2.27: Examples of New Construction and Rhythm

APPROPRIATE:

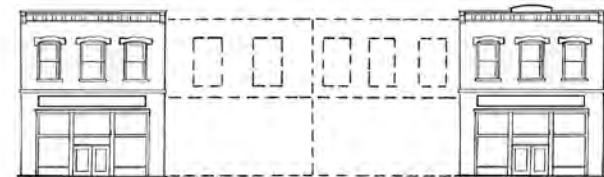

INAPPROPRIATE:



- 4.5.8 Design the roof form to be consistent with those of existing structures in the adjacent downtown area.
- 4.5.9 Design composition and fenestration should be compatible (shapes, sizes, placement of windows and doors, vertical or horizontal emphasis).
(For more information see Section A,1.7. "Sense of Place & Context" and Section B, Chapter 3 "Basics of Traditional Commercial Buildings.")

4.6. New Commercial Additions

When constructing an addition to a historic downtown building, it is important to realize that most historic buildings cannot support additions. Reasons are both physical and philosophical in the architecturally valuable downtown commercial historic district. Generally the historic downtown environment, with “zero-lot-line” construction and pedestrian-scaled sight lines, does not allow room for many additions. Adding major building features, much like removal of small features, has the potential to degrade the historic downtown environment.

Keep Additions in Context

- 4.6.1 If additional square footage is necessary, designing the new addition to the rear of the structure is preferred to adding another story, if space is available to the rear of the building.
- 4.6.2 Inset new walls in from the original corners and do not evenly extend roof planes when framing additions from off rear or sides of the building, allowing the original form of the historic structure to be “read.”
- 4.6.3 Ensure that the characteristics of additions embody those of the original architecture (massing, height, rhythm of openings and general type of materials), with the goal of complimenting, without exact replication of existing buildings or structures in the adjacent downtown area.

Rooftop Additions

Adding to roof areas can be a functional way to increase space or add living space to residential rehabilitations downtown. Decks, obscured visually by building parapets, are the most common form of roof addition as they are low and mainly “reversible” to the original building form.

Appropriate

- 4.6.4 Ensure deck additions do not adversely alter water run-off and ensure loads are positioned over load-bearing interior support.
- 4.6.5 If small rooms, decks, cupolas, skylights, mechanical or egress structures are added to roofs, ensure they are not readily visible from public streets, prominent pedestrian viewpoints, or scenic vistas. (The CAB may require illustrations showing the additions as they would be seen from other areas and will suggest the appropriate scale of additions.)

A building’s structural integrity and the height, scale and massing of surrounding buildings are paramount when determining whether a building can support an addition. Additions should match materials, and in size and scale relationships. Being able to differentiate the new from the old, however, is important. **To ensure compatible building design in the commercial areas and corridors of the Conway Historic Design Review Districts, all new additions should follow all of Section B, Chapter 4 “Commercial Architectural Guidelines” when project scopes cross over.**

Fig. 2.28: Examples of New Rear and Rooftop Additions

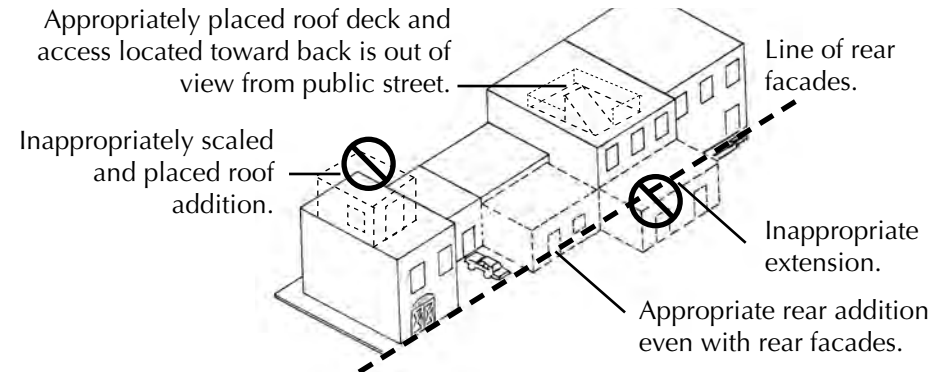

(Right) An appropriate addition to the roof of a previously one-story, one-part commercial bldg. in the Commercial HDRD, not located in the Downtown National Historic Register District. The original parapet line of brick was retained with a change of materials above to show where old ends and new begins. Balcony was stepped back from the front parapet.



Inappropriate

- 4.6.6 If adding full floors as additions do not visually make the building look “seamless.” This permanently alters the original building form. It is required that a visual separation of material and style is made.
- 4.6.7 Do not add through roofs just for the interior aesthetics of expanding interior ceiling height.
- 4.6.8 Do not remove important structural members to gain new roof access.

Adding Balconies

Upper facade balconies, over sidewalks, are not a historic feature of downtown Conway. Individual balconies on public street facades are discouraged in the historic design review districts today. Adding a balcony to an existing building necessitates an upper door be added, or window to be used as a "door," and this is unacceptable treatment of a building in a historic district. Original construction generally was not designed to bear bracing and weight of upper floor balconies. Support columns to the sidewalk may only be permitted in the case of existing upper doorways and substantiated historic research of the balcony as an original feature. Additional CAB review for scale and style will be required.

Appropriate

- 4.6.9 Small "Juliet balconies" off rear or non-public elevations and roof decks on neighboring buildings accessed from upper floor windows may be possible only if windows are tall enough or original upper floor door openings exist. Construction must be reversible.
- 4.6.10 If upper door openings do exist, research potential historic balcony and reconstruct historic balcony from historic photographs and documentation.

Adding Porches, Stairs & Patios

Buildings that require stairs, steps, or porches that were designed originally to the building will be apparent in the building form. Simply follow the original intent. Outdoor patios (at ground level on private lots) allow for versatility of dining experiences. Greenspace or vacant lots to the side or behind buildings may require easements for businesses to share use. **"Sidewalk dining" on public property, streets or alley-ways is a code issue.**

Appropriate

- 4.6.15 If necessary, add staircases (or fire escapes) to rear facades from existing window openings using a simple design with plain balusters (wood or metal square balusters painted or stained finish and spaced per codes).
- 4.6.16 Add handicap ramps or features, if needed, at rear facades, using wood with a plain rail and incline set to ADA standards. (See Section B, Chapter 4.1 "Doors" for more information on alternatives.)
- 4.6.17 Infill, storefront "facade-patios" may be constructed if NOT replacing historic storefronts and design approximates traditional openings.

Fig. 2.29: Illustrated Balcony Types

French or "Juliet" balcony fit into an appropriately scaled existing rear/side opening.



Widened opening, addition of a shallow or extended balcony.

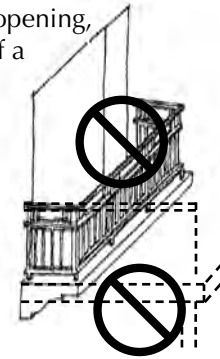

Constructing or extending balconies where none existed is not allowed in the CBD. They may be possible for an upper floor off a rear or non-public facade if tall enough openings exist. Constructed to fit into window openings must be reversible.

Inappropriate

- 4.6.11 Do not construct or extend balconies (including sidewalk "sheds") from front or side facades where none originally existed.
- 4.6.12 Do not cut new doors into upper facades or widen existing openings.
- 4.6.13 Do not extend new columns to a public sidewalk to support new balconies over a public sidewalk.
- 4.6.14 Do not construct braces or cantilever systems back into an existing building.

Fig. 2.30: Appropriate Patio Examples on Private Commercial Property

A new courtyard created from a vacant lot. Brick walls of appropriate height and openings continue contextual structural street frontage in front and rear.



A front dining patio created at an adaptive re-use of a service station with setback, preserving the original character of service bays.



A non-historic, in-fill facade with contemporary design contains a mid-block storefront-patio (with full-opening storefront). Facade is built to the property line.

Inappropriate

- 4.6.18 Do not add porches or staircases on front or side facades where none originally existed.
- 4.6.19 Do not intentionally remove historic storefronts, facade materials or facades to create an open "facade-patio."

Images: Conway & JB+A archives

SECTION C

TRADITIONAL COMMERCIAL SIGN GUIDELINES

Chapter 5:
Introduction to Sign Basics

Chapter 6:
Downtown Commercial Sign
Guidelines

5.1. Marketing and SIGN BASICS

The City of Conway has a sign ordinance, (*City of Conway Unified Development Ordinance, Article 11*) which takes precedent. These guidelines have been designed to work as a supplement of visual suggestions for traditional commercial building owners throughout all local Historic Design Review Districts (HDRDs). Significant focus is given to buildings in the historic commercial HDRD. It is the intent of this section to help building owners understand their building features and how the best scale, type, materials and placement of signage will benefit their businesses.

The quality and amount of signs on buildings has a great impact on the appearance of a downtown area, either positive or negative. Each and every storefront should be an individual statement for its intended market and audience, while also appearing in harmony with neighboring businesses.

Different types of signs serve different purposes in a downtown area. In most areas of any downtown, first impressions may be from an automobile, and certain signs are designed to be seen from that vantage point. Other signs are intended for the pedestrian to read while

strolling the sidewalk. **The building or retail owner’s choice of materials, size, scale and type of signage are reflective of the way that the business is intended to be portrayed.** A general rule of identification is that any patron needs only to recognize where a business is once. These traditional commercial sign guidelines provide for the multiple types of commonly used signs that are required for the best business visibility. This chapter suggests how to “read” individual buildings in order to identify proper sign placement depending on each primary facade and divide the facade area for “business divisions” if there might be multiple sign users.

With the City of Conway’s rich architectural history, exemplified by distinct building styles over many periods of its history, simple “marketing” rules related to signage remain basic:

- “KEEP IT SIMPLE”
- STAY IN CONTEXT
- USE APPROPRIATE SCALE
- FOLLOW GOOD SIGN PLACEMENT
- CREATE A “HIERARCHY” OF SIGN TYPES

“Keep It Simple”

While these guidelines are intended to prevent sign and visual “clutter” in the downtown district, they are primarily meant to guide the business owner as to traditional placement and good design. Keeping information and expression within established guidelines not only helps each business but the entire district as a whole.

Simple Signs - Residential Re-use:



Primary Signs Home, Yard Placement & Lighting: pg.D.17

APPROPRIATE:



Conway, SC 2009

Keeping sign clutter down, information simple, and aligned in traditional “sign-band” locations is important in the CBD where businesses are close together. Bold lettering or sign boards within prescribed architectural space is key.

INAPPROPRIATE:



jB-ra Photo Archives 2008

This is an example of a downtown commercial district that lacks signs where signs are meant to be. This does nothing to help these businesses promote themselves.

The Context of Signs

Beyond City sign ordinances, these guidelines should help identify and the use of sign construction appropriate to the building style and how the sign will be seen within the surrounding environment. Signs should work in context with the architecture of the individual building. Use fundamental features of the facade such as building piers, storefront cornices, and storefront framing for traditional and best placement of signs (Figure 3.2 next pg). Many upper facade features and stylized materials will provide built-in framing. Any new or reproduction sign should be consistent with the placement and type of signage that would historically have been used (or intended to be used) with that building. A building should not be adorned with signs that change the construction of the facade or the storefront. For example, overly "built" theme fronts and amenities that change the character of the architecture. The sign should be considered an expression of the type of business and therefore an extension of that individual business's identity, but also take in consideration the historic architecture.

If the storefront or business model is designed to utilize contemporary sign materials, a traditional approach with respect to placement, size and scale relative to the building features should still be followed. (Especially see "Scale" below.) In addition, the sign and its method of attachment should be reversible to the building itself to the greatest extent possible in order to maintain the integrity of significant building materials.

Use Appropriate Scale

Scale can be fairly subjective. Size limits set within City of Conway Unified Development Ordinance, Article 11 and additional suggestions, based on "sign types" in these guidelines, should help guide maximum scale on historic buildings. To judge "scale" each business must weigh the overall coverage of all signs being used on its facade, the perception the business is going to create, and how the signage aligns with neighboring signs. The average size of other signs in the immediate downtown environment might determine whether sign scale in a particular part of a district is smaller or larger than allowable. A marketing rule for scale is generally the smaller the sign and less information provided, the more sophisticated the business will be perceived. Businesses that cram type on out-of-scale signs are often perceived as lower-end or discount.

APPROPRIATE:



A single-bay contemporary framed storefront with traditional construction is shown here with an appropriate amount of signs. The design of a primary blade sign and secondary sign band over the door is in-context with the character of the space, the architecture and business.

INAPPROPRIATE:



Flat vinyl letters applied to an out-of-scale signboard construction are shown above. The entire sign is set across facade elements such as building piers, banding and slightly over the storefront opening edge. This becomes out of context to the traditional architecture.

APPROPRIATE:



Scale of signs work in a pedestrian oriented district and must not dominate the architecture. Note how upper facade architecture pre-defines size.

INAPPROPRIATE:



A sign that is too small for the large area of the upper facade is out of scale. This may interrupt the rhythm viewing signs and horizontal continuity of the block. The entire business may be overlooked.

5.1. Sign Basics (continued)

Follow Good Sign Placement

5.1.1 In no case shall a sign applied to a building be allowed to obscure any significant architectural details of a building face, nor shall a wall sign be designed to cover existing windows.

Fig. 3.1: INAPPROPRIATE Sign Placement



Signs placed over building elements and window openings will not be allowed.

Fig. 3.2: Contextual Types and Placement of Signs

For example only, all signs shown would not be allowed on one building:

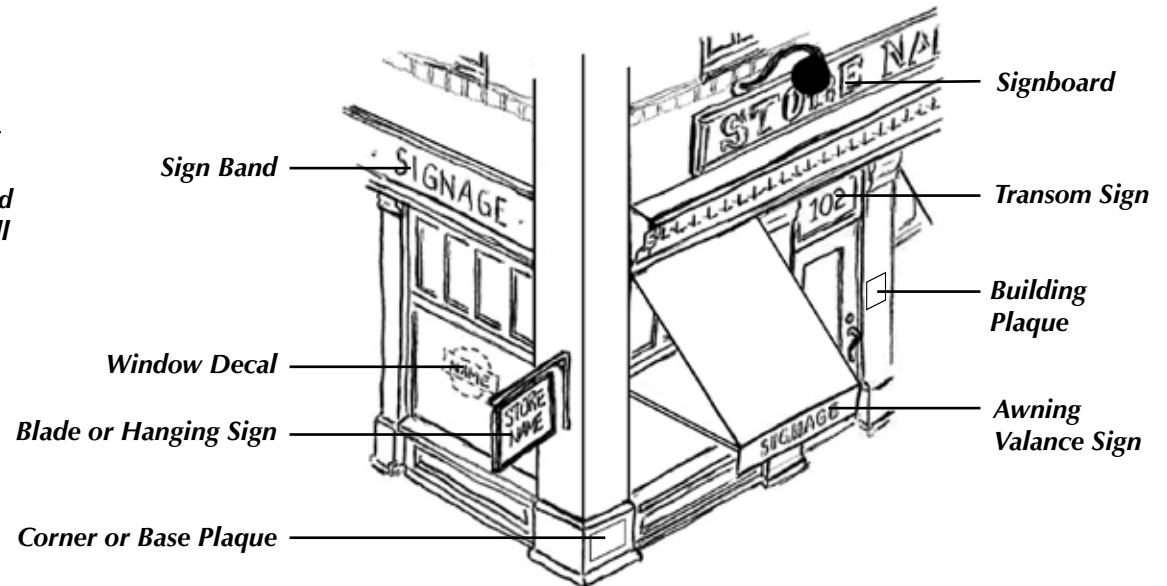

Create a Hierarchy of Sign Types

These guidelines use three different sign category terms to suggest a traditional system of sign “hierarchy” per business division, rather than per facade (see also Section C, Chapter 5.4 “Dividing the Facade for Clearer Signage”):

- PRIMARY SIGN
- SECONDARY SIGN(S)
- SUBORDINATE SIGNS

Quick Reference Guide to These Sign Guidelines:



Primary Signs: pg. C.8-C.9



Secondary Signs: pg. C.10



Subordinate Signs: pg. C.11

C TRADITIONAL COMMERCIAL SIGN GUIDELINES

Chapter 5 INTRODUCTION TO SIGN BASICS

5.2. Sign Materials

All attached signs should be (or appear) dimensional. It is not expected that all signs be “hand hewn” or crafted as they were 100 years ago from period materials. True dimensional letters catch light and cast shadow adding depth and highlight to the characters or logos during the day or night (see Fig. 3.3). (See page C.3 “Create a Hierarchy of Signs.”)

APPROPRIATE – Materials for Primary Signs in General

The images below are examples only, not all from Conway, they do not represent the only design for signs possible (as that is limitless and up to the creativity of the owner).



Applied Dimension



Stenciled Aluminum



Image Set on Stems



Routed Sign-Foam



Neon & Can-Electric (grandfathered historic and theatres ONLY)



Transfer w/ Border & Applique on Glass



Paint or Flat Print Sign

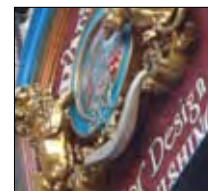

Mixed Use/Synthetic

Conway, SC, JB+a Archives, and National Trust

- 5.2.1 Wood is appropriate in cut, stenciled, routed, or dimensional letters.
- 5.2.2 Aluminum (stencil cut or mounted on “stems” from the sign board or anchors set into mortar joints on the wall).
- 5.2.3 Synthetic modern materials such as toolable sign foam, applied pre-fab and primed-paintable dimensional lettering, “Cintra” brand board, or fiberglass reinforced plastic (FRP).
- 5.2.4 Hand-painted signs with implied dimension.
- 5.2.5 Any creative mix of sculptural layers of appropriate material.
- 5.2.6 Stencils or metallic foiled lettering should be used as material for applied window signs of any type. Give these dimension with an additional applied border (contrast color to lettering or black) outline (See Pgs. C.5 & C.6 for appropriate definition and use of neon materials.)

Fig. 3.3: Typical Dimensional Lettering and Paint Example

Colors suggested for Example Only:

Dark or light background Painted trim line Contrasting (to background) or metallic letters



Shadow from dimensional lettering

Depth could be painted with faux dimension on flat surface, or lettering edges painted for contrast

INAPPROPRIATE – Materials for Primary Sign in General

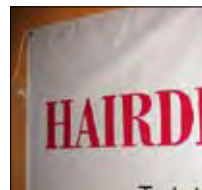

Vinyl Banner or “transfer” applied letters on any surface should not be used as Primary Sign material.

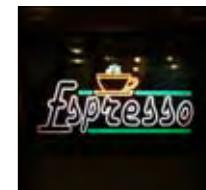

Plastic Internally Lit box signs should not be used as primary or secondary signs. They may be used as a “subordinate sign” type, if not in the NRHD.

The very few “inappropriate” materials for signs proves that good, unique signs can be created from just about any medium. Context, placement and scale are more important.

- 5.2.7 “Quick” signs of vinyl lettering, heat transfers, or stick-on lettering used as Primary Signs have a cheapened and non-durable appearance for the business. This may be applied as a “secondary” or “subordinate” sign on awning valances and some window applique (see also Section C, Chapters 6.2 and 6.3, respectively).
- 5.2.8 Back-lit plastic light box or plastic neon-appearing signs should be avoided as Primary or Secondary Signs.

5.3. Sign and Architectural Lighting

Lighting of signs (and buildings) should be taken highly into consideration by every building or business owner. Evening hours are the time when many businesses are viewed from passing cars or pedestrians. More focused “direct marketing” can be achieved with an appropriately lit sign at night than during daylight hours when the entire downtown environment may visually distract. Traditional, possibly reproduction fixtures, and stylistically appropriate forms of lighting (Figure 3.4) within the Conway Commercial HDRD will be required.

SPECIAL NOTES:

- 5.3.1 The Community Appearance Board may determine in specific cases or in general that brightness or the amount of lighting is unnecessary to the environment or architecture.
- 5.3.2 Holiday lights or interactive seasonal displays are welcome, however are only temporary. Ensure holiday displays encroaching on sidewalk space and/or displays do not shine in pedestrian’s eyes.
- 5.3.3 Allow artful use of new lighting technology. Light Emitting Diode (LED) light sources are effective in creative and innovative sign packages and architectural lighting. The Community Appearance Board will require additional review of timed fades, brightness, and amount or type of housing the LED is set into.



(Left) New light sources. Light Emitting Diode (LED) “strings” are being used as sources for internal and creative sign lighting (These can be fixed or set with slow fades and changeable colors with special approval.) Close-up shown from inside.

True NEON vs. “Neon-Appearing” Signs

- 5.3.4 Exposed gas-filled neon tubes should be used **ONLY** to illuminate the name of the business or corporate identity as a Primary Sign.
- 5.3.5 **Within the Conway Downtown National Historic Register District:** gas-filled neon may **ONLY** be used if designed for a building facade style that would have used neon, as “grand-fathered” historic neon.
- 5.3.6 **Within any of the local HDRDs:** “Neon-appearing” signs should be avoided. Gas filled neon, LED or stenciled backlit may be used to “silhouette” stand-off lettering only in the name of the business or corporate identity as the Primary Sign. (See Pg. C.6 for all other sign lighting.)

Fig. 3.4: Reproduction and Contemporary Lighting Sources

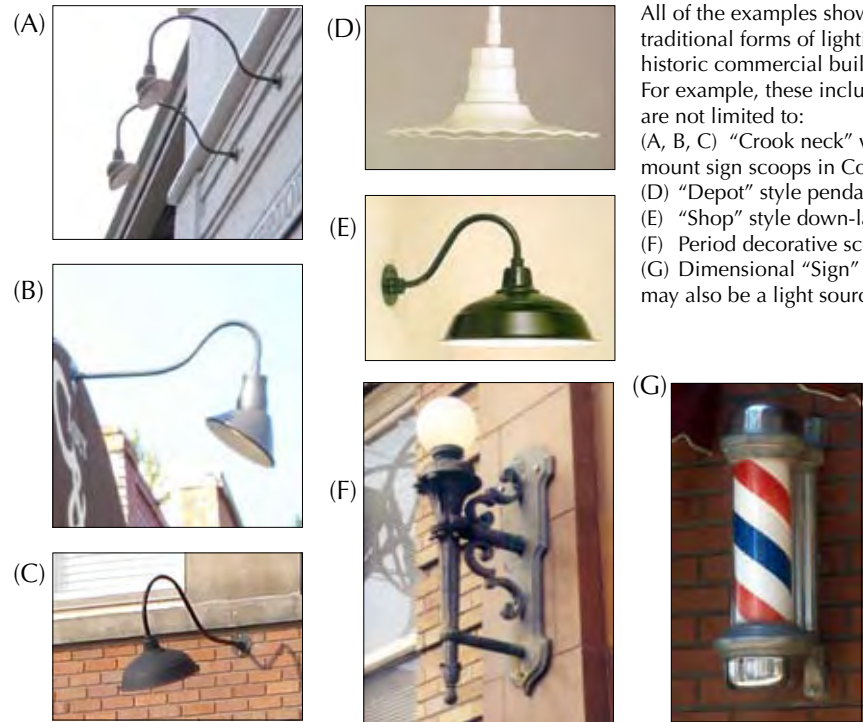

All of the examples shown are traditional forms of lighting on historic commercial buildings. For example, these include but are not limited to:
 (A, B, C) “Crook neck” wall mount sign scoops in Conway
 (D) “Depot” style pendant
 (E) “Shop” style down-lamp
 (F) Period decorative sconces
 (G) Dimensional “Sign” that may also be a light source.



(left) Conway Main Street Theatre, (right) silhouetted neon Seattle, WA

Only exposed gas filled neon tubes are grandfathered on the theatre marquee in the Conway Downtown NRHD (left), other neon uses can be used throughout remaining HDRD (example right).

NEON NOTE:

- 5.3.7 Gas-filled neon tubes are often used for product endorsement, however must follow the guidelines for “Product Endorsement Signs” as described in “Advertising and Other Signs” (Section C, Chapter 6.4).

APPROPRIATE SIGN LIGHTING METHODS:



conway, SC 2009

Small sign-mounted "arm" light



Conway, SC 2010

Front-lit traditional down-light top-scoop



jB+a Photo Archives

Internally-lit sign "boxes" with stenciled letters - (Day-left / Night-right)



Both images: jB+a Photo archives

Silhouetted dimensional lettering: stenciled & covered-internally lit (left), LED "can" (right)

APPROPRIATE SIGN LIGHTING METHODS:

- 5.3.8 FRONT-LIT OR DIRECT lighting with, scoop, arm, or reproduction "crook-neck" commercial sign lights traditionally mounted above the sign board from the wall. Modern halogen pin spots mounted below on wall, frame, thin metal arms, or canopies can be used.
- 5.3.9 Gas filled neon is allowed ONLY in special circumstances (see Section C, items #5.3.4 - 5.3.6 "True NEON vs. 'Neon Appearing'").
- 5.3.10 Sculptural layers of material (creatively lit from behind or within) to create "silhouetted" lettering at night, or stand-off lettering that use shadow from the front lit sources for creative effect.
- 5.3.11 Covered lighting sources can be LED "strings" or neon tube.
- 5.3.12 Architectural lighting accenting building details with pin spots, light columns, low-watt washes, planters, etc. must be removable. Additional approval is needed for timing slow changing fades or washes.
- 5.3.13 INTERNALLY-LIT signs should be done in a minimal manner with the least amount of light "spill." (See day / night example above.)

INAPPROPRIATE SIGN LIGHTING METHODS:



jB+a Photo archives

Full internally-lit plastic sign or awning.



jB+a Photo archives

Light emitting diode (LED) signs set to scroll, blink, strobe, flash, etc.



Internally-lit plastic-front channel letters.



Internally-lit plastic & LED OPEN signs

INAPPROPRIATE SIGN LIGHTING METHODS:

- 5.3.14 FULL, INTERNALLY BACK-LIT plastic, vinyl or illuminated box signs or back-lit awning signs are not allowed.
- 5.3.15 Animated or electronic signs. Primarily programmable Light Emitting Diode (LED) read-out or digital screen video . Electronic signs may be Product Endorsement signs and should follow all placement suggestions (see "Advertising and Other Signs" Section C, Chapter 6.4).
- 5.3.16 "Channel lettering" (individual, internally-lit dimensional lettering) cannot be used as the entire sign or logo. Some internally-lit sign elements may be appropriate if designed as a part of a creative dimensional sign package.
- 5.3.17 Bright flashing, strobing or quickly changing colors are not allowed.
- 5.3.18 Do not use any electric signs with boxed "raceway" for electric or mounting exposed.
- 5.3.19 Avoid backlit, molded or neon-appearing "OPEN" signs if possible, especially in the National Register historic districts to preserve character.

5.4. Tips for Arranging Facade Signage

The following steps are not required by Conway Sign Code. This is a suggested method to assist the proprietor and building owner organize a division of signs in the case of multiple businesses per one facade.

The suggested size, area and hierarchy of different sign categories (see Section C, all of Chapter 6 “Downtown Commercial Sign Suggestions”) can be based on three simple steps of dividing facades with multiple businesses.

Step 1: Identify Primary Facade and Estimate Division by Physical Usage
 Every building has one Primary Facade and buildings with multiple businesses may need to share the facade area for signs. Most businesses will occupy a single storefront or primary facade facing the street; however tenants may also locate in a corner multi-level space, or locate only on upper floors with no display windows. Who get’s the “most” signage? This hypothetical “business division” can make it easier to determine sign sizes and amount for each business. Some business blocks have equally divisible storefronts (i.e. single story side-by-side; row of identical storefronts; upstairs / downstairs) and some may be less equally divided in the primary facade (50/25/25%; etc.). In instances where corner or stand-alone businesses have multiple facades, only one facade is designated as the “Primary Facade” which in turn provides the location for the one allowable Primary Sign described later.

Step 2: Estimate Square Footage to Assign to Each Business
 Generally, each “business division” can be given a length and height of each individual business on the primary facade. The resulting square footage that each individual business is assigned determines the amount of facade exposure to begin to figure sign sizes and amount per business.

Step 3: Use these Guidelines for Suggestions on Sign Types and Amount
 Different amounts of additional signage can be measured back to the Business Division of the Primary Facade (see all of Chapter 6 “Downtown Commercial Sign Suggestions” in the following Section C, Chapter 6). The example in Figure 3.5 shows that Signs do not have to be placed only within the “business division” assigned to that specific business.

Fig. 3.5: Defining a Hypothetical “Business Division”

For suggested use only to assist with sign placement, amount and hierarchy. This is not code enforced.

Business A

- Corner Retail
- 2 Stories
- 2 Public Facades (owner designates front as “Primary Facade”)
- 500 Square Foot “Business Division” of Primary Facade

Business C

- Upper Floor Office
- 300 Square Foot “Business Division” of Primary Facade

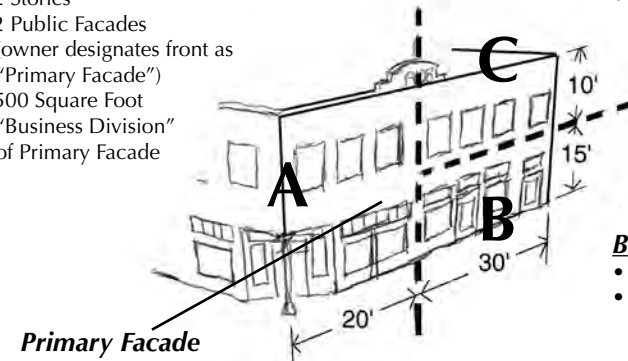

Business B

- Street Level Retail
- 450 Square Foot “Business Division” of Primary Facade

(Above) The building owner has elected to divide the primary facade into three parts: “Business Divisions” A, B & C. Each have different square footage of the area of the primary facade. Each have their own entry to the street.

(Below, left) Businesses A, B, and C could join together to place a single sign, such as Conway’s “Back Water Market,” across the sign band area, even though each business sells different goods. Secondary signs would give individuality.
 <OR>

With individual signs scaled to the amount of each assigned business division:
 (Below, right) Business C (upper floor) affixes a Primary “blade” Sign (see Fig. 3.6 Suggested Primary Sign Types) over its street entry door, even though the door is part of the lower facade business division. Businesses A and B choose mounted Primary Sign boards over their storefronts in scale with the amount of their business divisions. This gives business A the largest Primary Sign, followed by B and then C.

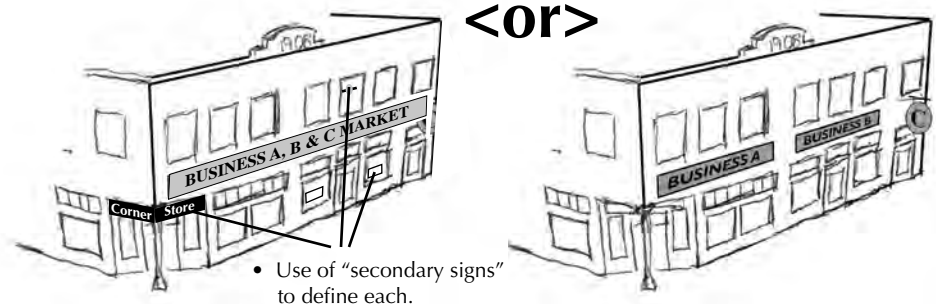

- Use of “secondary signs” to define each.

6.1. The Primary Sign

Description and Use:

The PRIMARY SIGN is NOT expressly defined as such in the *City of Conway Unified Development Ordinance*. This sign “category” is exemplary within these guidelines ONLY for the most traditional use and placement of the most dominant sign (i.e. largest in size and prominently placed on the upper facade, hung from public exterior, brightest lit, etc.). (Fig. 3.6)

- 6.1.1 The Primary Sign should ONLY be the business name, logo or business type (i.e. “Bicycles,” “PIZZA,” “Food,” “EAT,” “Loans,” etc.).
- 6.1.2 The Primary Sign may be a dimensional icon, graphically depicting the type of business.
- 6.1.3 A side wall mural may become the Primary Sign and will probably exceed the suggested size on that facade. A variance may be granted for a wall mural sign if the CAB determines it appropriate; however, any other signs on any facade will be “secondary” to this sign. Painting on unpainted historic, natural brick surface may not be allowed.
- 6.1.4 Awnings should NOT be used for Primary Signs, as they are a building amenity; however, awning valances may be used for Secondary or Subordinate Signs.

Significant Historic “Grandfathered” Signs:

(As identified by the CAB) these signs MUST be retained as they are part of the history of the facade, storefront or building in some way.

- 6.1.5 Grandfathered historic signs may be covered with new board or neon re-worked to accommodate a new business as long as modifications are “reversible” to the historic sign.

Suggested Amount:

- 6.1.6 ONE Primary Sign per “business division” of the primary facade (see Section C, Chapter 5.4 “Dividing the Facade for Clearer Sign-age” to see suggestions on visually dividing the facade per usage). A SECOND Primary Sign may be used on a corner building with 2 facades.

General Size Suggestions:

- 6.1.7 Primary signs, with the exception of projecting hanging signs, may be a maximum of 100 square feet or 15% of the building face where the sign is attached, whichever is less.

- 6.1.8 The widest point of ONE dimension (vertical or horizontal) of the Primary Sign should not exceed three (3) feet, or fit into a circular diameter of five (5) feet. No Primary Sign should exceed 100 square feet.
- 6.1.9 Window signs (as Primary Signs) on or above the second floor may obtain a variance to cover no more than 30% of any one window.
- 6.1.10 A hanging or projecting sign, known as a “blade” sign, will usually be much smaller than the allowed general size based on construction limitations. The size of a blade sign depends on the room for, and style of, the bracket hardware, adequate space for stabilization (if wires are needed), and weight/stress on the building. These factors, plus the projecting space over the storefront coupled with potential right-of-way liabilities, will usually lead to this reduction in size from a mounted Primary Sign. **Generally, blade sign size is within eight to ten square feet.**

SPECIAL NOTES:

- 6.1.11 The Community Appearance Board may determine, in specific cases or in general that the full size suggestion is too large “in-scale-to” or obstructing significant architecture. The CAB will suggest an appropriate size. Primary “blade” signs will usually be much smaller than the maximum allowed size. Awnings should generally not be used as primary signs, however if granted the lettering placement and size will require additional review (see below).



In very few circumstances should Primary Signs be mounted on an awning. If the business should happen to change the entire awning becomes irrelevant. In the example there is room for a horizontal sign board above and the awning can be mounted slightly lower for more sign room. If the only option is an awning sign, scale and placement of the lettering must not be obtrusive. Awning lettering should follow primary sign suggestions.

6.1. Primary Signs (continued)

Fig. 3.6: Suggested Primary Sign Types



In the example above, a dental practice may have a Primary Sign that will read "HAPPY TEETH ON MAIN" – which is the actual name of the business – or simply "DENTIST." It will be the most predominant sign on the facade in one of three configurations shown:

- (A) a perpendicular hanging sign, or "blade" sign, over the sidewalk and storefront, side or corner mount,
 - (B) mounted or painted to a flush surface on the building designated for sign use, or
 - (C) the sign may just be a large fiberglass tooth hung from the side, front or corner of the building.
- NOTE: a second Primary Sign may be used on additional facade of a corner building.



jB+ra: Conway, SC 2009

Combination mid-century primary (& secondary) sign appropriate to significant (ca.1940s) auto-oriented commercial on Elm Street. With new business only a change in the panels should occur.



jB+ra: Conway, SC 2009

A commercial building downtown with one primary sign and multiple businesses has a well defined area above the storefront for a flush primary sign board defined by brick banding.



jB+ra: Conway, SC 2009

Flush primary signs centered to the front of the main storefront and a second, primary sign centered over a display on a side facade. Signband area is defined by the architecture. These primary signs are scaled well with the largest over front.



jB+ra: Conway, SC 2009

Businesses in Conway are starting a trend of elaborate, artistic blade sign brackets and hardware for primary signs. This is a unique feature to Conway as a district and the dimensions of the hardware add another level to the signage.

The above images are for example only. This does not represent the only application and design of signs possible, as every building and allowable sign area is individually unique.

C TRADITIONAL COMMERCIAL SIGN GUIDELINES

Chapter 6 DOWNTOWN COMMERCIAL SIGN SUGGESTIONS

6.2. Secondary Signs

Description and Use:

SECONDARY SIGNS are NOT expressly defined as such in the *City of Conway Unified Development Ordinance*. This sign "category" is exemplary within these guidelines ONLY for the most traditional suggested use and placement of additional signs, generally secondary, to the Primary Sign or "supporting signage" to the business name or identity (Fig. 3.7).

- 6.2.1 Secondary Signs can be located in many places on the facade, and they must be approved by the CAB to be "secondary" in nature to the Primary Sign. This includes repeated, matching signs in display windows.
- 6.2.2 The Secondary Sign may be the business name or the type of business applied to the valance or "skirt" of the primary awning.
- 6.2.3 The Secondary Sign may include tag lines below the name, graphics, or proprietor / professional's name and title, or slogan.
- 6.2.4 The Secondary Sign could be a dimensional icon graphically depicting the type of business; however it SHOULD be smaller than the Primary Sign as described below.
- 6.2.5 Neon, channel letter or any internally-lit signs are NOT permitted as Secondary Signs.

Suggested Amount:

- 6.2.6 Generally ONE per "business division" of the primary facade, with the exception of matching window signs (see Section C, Chapter 5.4 "Dividing the Facade for Clearer Signage" for suggestions on visually dividing the facade per usage).
- 6.2.7 An identical PAIR (set) of window signs (on multiple display windows) can be counted as one Secondary Sign. (Fig. 3.7)

General Size Suggestion (each):

- 6.2.8 Suggested at 20% or less of the square footage of the Primary Sign.
- 6.2.9 **At any time, no single window should be covered more than 25% and no single door glass more than 50%** (*City of Conway Unified Development Ordinance*, Article 11). Window signs on or above the second floor (if upper levels are used as part of the primary business at street level) should be limited to one or two words (i.e. "PUB," "Dentist," "TAT-TOO," or "Law Firm"), or simply not used at all to avoid clutter.

Additional Sign Suggestion (to reduce clutter):

- 6.2.10 If the business is located on a corner, occupies multiple storefronts, or in a stand-alone structure, then EACH facade (storefront) might have one (1) additional Secondary Sign upon that facade. NOTE: The entire business should still have only one (1) Primary Sign, however.
- 6.2.11 If there is an identical window sign (to create a pair) within a separate display window pane, and each conforming to the size limitations listed above, then the pair (set) might be used.
- 6.2.12 When using multiple lines of type or full logos in mass, at their widest point, should not exceed three (3) feet. Single lines of type or line graphics might be exempt from this limitation.

Fig. 3.7: EXAMPLE of Suggested Secondary Signs

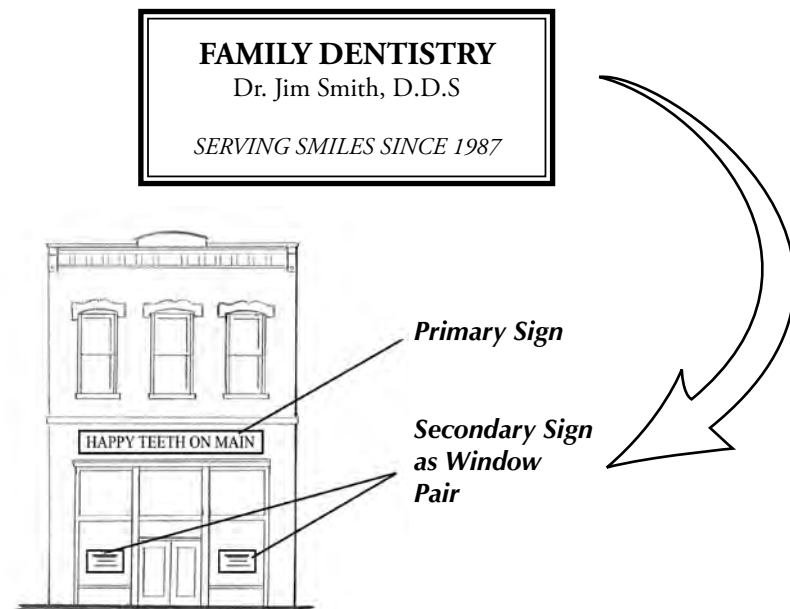

Using the Flush Primary Sign, from the previous Figure 3.6, the Primary Sign reads "HAPPY TEETH ON MAIN." The Secondary Signs are applied as a pair of signs to the two storefront windows. NOTE: This is a matching pair of signs as suggested to count together as one Secondary Sign – the dentist may still place "Subordinate Signs" described next.

6.3. Subordinate Signs

Description and Use:

"SUBORDINATE" SIGNS are NOT expressly defined as such in the *City of Conway Unified Development Ordinance*. This sign "category" is exemplary within these guidelines only. Subordinate signs generally are not the name and/or identity of the business, yet this sign type is necessary for operating a business and intended for pedestrian information (Fig. 3.8).

- 6.3.1 Subordinate Signs are generally small type, decals, window hangings or icons intended to be viewed by the pedestrian and patron.
- 6.3.2 Subordinate Signs may consist of, but are not limited to: "OPEN" signs; store hours; credit cards accepted; menu postings; a repeat of the business name and/or logo; a store slogan; proprietor's name, etc.
- 6.3.3 Neon and internally-lit box signs are not suggested within the Downtown National Register District, and in remaining local Historic Design Review Districts subject to additional CAB review of brightness, to verify no flashing or changing color, and to help with placement if they are Product Endorsement signs (See Section C, Chapter 6.4).

Suggested Amount:

- 6.3.4 Usually MULTIPLE groupings (see Size Suggestion, Combined Total below) to make up a "comfortable" amount of Subordinate Signs per "business division" of the primary facade (see Section C, Chapter 5.4 "Dividing the Facade for Clearer Signage" for suggestions on visually dividing the facade per usage).
- 6.3.5 A business which occupies multiple storefronts and/or has side or corner display windows can use additional Subordinate Sign(s).

Size Suggestion: (COMBINED TOTAL)

- 6.3.6 ALL Subordinate Signs square footage on the primary facade are suggested to fit into a COMBINED TOTAL of about 3 (three) square feet.

Additional Sign Suggestion (to reduce clutter):

- 6.3.7 ONLY if the business occupies multiple storefronts and/or has side or corner display window area then additional Subordinate Sign(s) should be used per extra facade.
- 6.3.8 Groupings of Subordinate Sign(s) per additional facade are suggested to fit into two (2) additional square feet, per that additional facade.

Suggested Placement (close to the public entrance):

- 6.3.9 ONLY place on windows or display areas (this may include main entry door window panels).
- 6.3.10 In display windows, the outside perimeter of Subordinate Signs should be placed within 2 1/2 feet inward from the entry side frame of the window glass and the top perimeter of the sign within 2 1/2 feet up from the bottom display sill. (It may also be centered within adjacent display windows with top perimeter of the sign within 2 1/2 feet up from the bottom display sill.)
- 6.3.11 On entry doors, Subordinate Signs should be either centered or set to the bottom portion of the door panel glass.

Fig. 3.8: EXAMPLE of Suggested Combined Subordinate Signs

Open sign cards can be used as subordinate signs as well as transfer type.

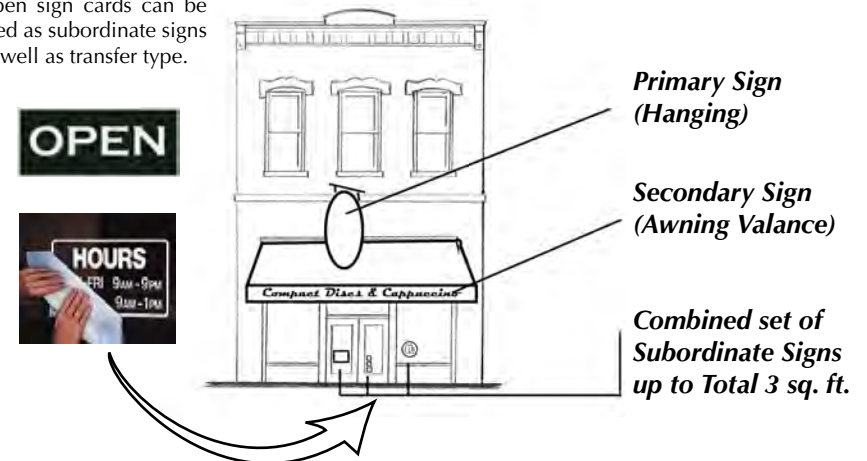

In the figure above, a business Primary Sign may read "MUSIC AND MORE," on a perpendicular hanging sign above the entry. The Secondary Sign is less prominent, on the awning valance in vinyl type lettering reads "Compact Disks & Cappuccino." The Subordinate Sign consists of a 1 x 1 foot square vinyl transfer "hours" in the door glass that also reads "Sorry, No Checks" in small writing across the bottom. This leaves the owner a remaining 2 square feet of the total suggested Subordinate Sign limit. The owner places a one-and-a-half square foot "OPEN" sign card within the main display window to the right of the entry. To keep within the suggested 3 square feet total of Subordinate signage, the remaining half square foot is an assortment of credit card stickers in the door glass.

NOTE: If the business is also a corner location or occupies multiple facades, a two-foot of this same subordinate information may also be placed in a side display window.

6.4. "Grandfathered" & Historic Identification Signs

As businesses change, signs are generally placed in the same location and sensed in the same intended manner, even as the signs change. Some signs themselves, however have withstood the test of time or have become a part of the fabric of the commercial environment and can be "grandfathered."

Description and Use:

- 6.4.1 A "grandfathered" sign may still be connected to a long-time business, a "last example" of a type or style of a sign no longer produced or may be "built in" to the significant type (or style) of architecture in such a manner, that removing the sign (hardware, structure or verbage) will change the building's appearance or historic context to the area. Good examples can be found inside and outside of all Historic Design Review Districts in Conway (Fig. 3.9).
- 6.4.2 Not every sign can become "grandfathered." These signs must "earn" their significance over time, notariety, familiarity, creativity or history to the community, and be identified as such by the CAB.

Suggested Amount:

- 6.4.3 Generally, retain whatever the CAB determines is contributing to the hardware, structure or verbage of the significant sign in order to best preserve it's history with the building.

Suggested Retrofit or Updating of a "Grandfathered" Sign:
Always retain a "Grandfathered Sign" deemed important by the CAB. If a new business has a different name then the sign deemed as "Grandfathered" by the CAB:

- 6.4.4 Use sign as a landmark or the historic name of the building/site. A visual structure, such as a sign (like the old Conway car dealership at Fourth Ave & SC501, the impressive scale and high-style construction of the Nye's Pharmacy or the striking neon glow of the Main Street Theatre, to name a few) create a great "sense of place" and can anchor placemaking concepts. The smallest signs like the metal advertising signs rusting away on the Cotton Warehouse or larger commissions like the downtown steamboat mural give identity to a location. Smaller, new business signs can be hung with the new business name or business type in secondary locations on the building facade.
- 6.4.5 Painted wall advertisements, murals or signs can become "ghost signs." These can be decidedly re-painted if studied and photo-documented, and given approval by the CAB. Some, for nostalgia-sake and patina can be left to the elements and simply allowed to "fade away."
- 6.4.6 Retain the sign form, casing and structure while "re-skinning" the face of a grandfathered sign with sheet metal or a covering that will not damage or hold water against the old sign face. Often reworking neon tubes to show a new business can re-use the sign casing (Fig. 3.9).

(From City of Conway Unified Development Ordinance, Article 11 "Signage")

"Grandfathered" Signs: Signs, or sign hardware, of historic significance (such as those relating to an original business, that have a built-in nature to a signfiicant form or style of historic archtiecture, or the nostalgic name of a business that has come to define a site for a long period of time) shall be granted an exception to requirements found in Article 11. The CAB shall determine if a sign is of a historic nature and should be considered as "grandfathered" using Technical Preservation Brief #25 "The Preservation of Historic Signs" (established by the National Park Service, U.S. Department of the Interior) and/or the "Conway Historic Design Review Districts: Community Appearance Design Guidelines."

VS.

Historic Identification Signs: Small date markers, "National Register" identification plaques, history signs or site identification markersthat are part of a local or regional tourism initiative shall be granted an exception to requirements found in Article 11. These should be approved for size, placement and method of attachment by the CAB.

Fig. 3.9: Examples of "Grandfathered" Sign Types & Solutions

Public Enhancement-Murals



Conway, SC 2010

The Conway "River City Steamboat" wall mural is practically a landmark. Wall signs or advertisements this large would not generally pass current sign regulations. In cases of public enhancement it would take special review. This mural is "grandfathered" and may benefit with careful repainting some day.

"Grandfathered" Sign → Retrofit



Covington, GA (left: 1999 / right: 2005)

(Left/right Above) The same sign in a National Register Historic District, deemed by the local historic review board as "grandfathered" to the building and downtown setting. When the business changed a new sheet metal "skin" was screwed over the faces and new gas-neon designed.

Attached, "Historic" Signs



Conway, SC 2011

Some advertising shows bygone products, businesses or have become part of the "character" of an area. In designing new signs for the large warehouses in the WRD HDRD the CAB would take in account the sheer amount of wall space where attached signs and old signs may be grandfathered over the current regulated amount requirements.

Back-lit, Mid-20th Century



Conway, SC 2009

In this case, mid-20th century signs are to significant to the ca.1940s original (intended) commercial architecture.

With a new business consider changing the upper panel of the large sign (use stylized new graphic) and retain the under-canopy mounted sign box for history.

Structure, Mid-20th Century



Conway, SC 2011

This sign (and existing pharmacy business) are a true landmark to the community west of the Central Business District.

Extremely significant to the development of Fourth Ave., and its physical presence, it would be difficult to imagine the area (or vernacular bldg.) without this sign.

Built-in, Architectural Marquee



Conway, SC 2009

What would the night-scape of downtown Conway be without the flash and electricity of the historic *Main Street Theatre* marquee? Even daytime, the art-deco styling of the building and composition of the facade are designed to have this sign structure as part of the architecture. Neighboring storefront uses the design motif.

Painted, "Historic" Business



Conway, SC 2009

The painted "Conway Hardware Co." sign is old and could be saved as a "ghost sign" with a new business using attractive window signs or hanging signs.

This is a good example of a sign that can have another sign panel carefully installed over the face to preserve the lettering.

C TRADITIONAL COMMERCIAL SIGN GUIDELINES

Chapter 6 DOWNTOWN COMMERCIAL SIGN SUGGESTIONS

6.5. Advertising and Other Signs

APPROPRIATE:



INAPPROPRIATE:



Product Endorsement signs (Staff Review):

Signs for products (i.e. "Timberland Boots," "Seattle's Best Coffee," etc.) should NOT be mounted or fixed on the building, nor directly to or against the display glass in any form. Product signage should be placed on display boards set at least two (2) feet back within the interior entry or window cases (display case space permitting), or mounted on interior side walls within the display window viewable area.

Neon, LED or internally-lit product endorsement signs may ONLY be placed on the interior side walls at least 4 (four) feet from the inner surface of the display window or on a rear wall parallel to the display windows, within the establishment.

Special consideration for permanent endorsement signage, such as product wall murals, may be issued by the CAB, however it is highly suggested the product have something to do with the business. Mounting or turning the side of a building into a "billboard" is unfavorable.

Specific product endorsement AS a Secondary sign ONLY IF it is a corporate re-sale franchise of that product and it conforms to the guidelines of a Secondary Sign (see earlier this Section C, Chapter 6.2).



Temporary "SALE" or Event Banners (Staff Review):

There are many different types of temporary banners recognized by the *Conway Unified Development Ordinance* with size requirements and time limits (in days). Generally these are large, vinyl lettered, "quick" production signs on flexible material that cannot be used for permanent primary or secondary signs. On the exterior they should be attached with ties. On the interior, these include anything hung within three (3) feet from the inner surface of the display glass. Any one side of a "SALE" banner should not exceed three (3) feet across and should never obstruct pedestrians.

Advertising signs, which tend to be of more temporary-quality, should be used sparingly as to not cheapen the environment of that business or those nearby.



Pedestrian Zone Advertising (Staff Review):

Usually in the form of A-Frame or "sandwich board," sidewalk signs are permissible and can be a pedestrian amenity in the Conway Downtown Historic Design Review District - get creative! However, they may only contain daily specials, menus or sale items in erasable type such as chalk or dry-boards. Placement is in the pedestrian zone directly adjacent to the business. Height should not exceed four (4) feet and the sign should not take up sidewalk area of more than six (6) square feet. **There must be a minimum of a four (4) foot distance to pass between the Pedestrian Zone sign and building, or any immobile street amenity such as benches, bike racks, trees, post boxes, stairs, etc., as the sign can become a hazard to the public right-of-way. It CANNOT be placed on a handicap ramp or on curbs.** These signs must be removable and taken inside by the business when closed, in case of downtown events, and/or for emergency purposes. **Pedestrian Zone advertising is highly contingent to ongoing review by the CAB** on the amount of product endorsement, amount of information placed upon them, attractiveness, and content deemed appropriate to the business of the district as a whole.



Historic, Directory or Address Information (Staff Review):

Street numbers, date plates, local historic site identification or "National Register of Historic Places" plaques are usually small and ancillary to any of the day-to-day business functions of a particular building. These may be mounted, in addition to all of Section C sign types, in a manner that is as un-obtrusive as possible to the business or the architecture on the facade. **The CAB can determine if an address/information sign is out of scale.**

SECTION D

MAIN ST. CORRIDOR HDRD & (Voluntary) RESIDENTIAL GUIDELINES

Chapter 7:
Basics of Traditional Residential Buildings

Chapter 8:
Residential Restoration and Architectural
Design Guidelines

Professional/Commercial Infill Along Main St.

At Fifth Avenue, going north, Main Street transitions from the Commercial Historic Design Review District (HDRD) into what the Community Appearance Board has classified as the "Main Street Corridor Historic Design Review District." Essentially the character of Main Street, at this intersection, changes from the mostly dense commercial environment to that of a residential and neighborhood-commercial character. Sidewalks with lawn "aprons" between the walk and the street, lot sizes, set backs, and scale of the buildings are not the only thing that changes within this HDRD when compared to the Commercial HDRD. A more natural environment of yards, trees, and "green space" between buildings (mostly set to the center of lots) is prevalent from Fifth Avenue all the way to almost Sixteenth Avenue, where the Main Street Corridor HDRD ends. The Main Street Corridor HDRD boundary (and required CAB Historic Design Review) applies to those properties on each side of, and facing, Main Street for this length.

The properties on the west side of Main Street (just north of Fifth Avenue to just north of Tenth Avenue) are also collocated within the boundary of the Conway Residential National Register Historic District (see map Fig. 1.1, Pg. A.5). For these properties there are greater options for historic tax credits and a more significant tie into the correlation of the older in-town neighborhoods and house forms.

Use of buildings is primarily residential but overlay zoning districts also allow for professional office. Since the mid-20th century small offices (attorneys, dentists, architects, health offices, etc.) were constructed in vacant lots between the larger homes and (or in place of) established residences. The scale of these commercial entities, however, is unique to the Main Street Corridor, as opposed to the buildings found along the Fourth Avenue auto-commercial-corridor, which would have been developing at the same time. Where it appears Fourth Avenue was, between the 1930s - 60s, more under-developed to which service stations, car dealerships, cafeterias, and strip centers located there. N. Main Street was already primarily residential entirely to at least Fifteenth Avenue prior to 1950, so professional offices were built to be site-specific and in scale with the neighboring homes.

In the late-20th century, until today, some lots were consolidated to construct modern church buildings and professional complexes. New businesses are built in house form, but many homes themselves are large enough for retail or offices, with basic modifications for ADA access. The latter is preferred.



All images, Conway, 2009

Cottages, bungalows, Georgians, and a few Queen Anne house forms along Main St., just north of downtown, reflect the continued prosperity of the city. Many are now businesses (above-left). Most of the residential areas have sidewalks and mature trees and lot usage is controlled with zoning.



Small, mid-20th Century professional buildings (left) in the highest styles (generally International Style) are a historic character and growth-defining feature of the corridor. In the last block of the HDRD south of Sixteenth Street (below left) a definitely more auto-oriented, neighborhood scale took shape. Mid-century neighborhood churches (below right) are found within these blocks.



All images, Conway, 2010



All images, Conway, 2009

As homes are converted to commercial use (left) or new construction with residential form (right) is designed on lots, the challenge for the Main Street Corridor becomes the balance of maintaining a high level of in-town residential character (from varying decades of development) with the needs of the business.

D MAIN ST. CORRIDOR HDRD & (VOLUNTARY) RESIDENTIAL GUIDELINES

INTRO CONWAY'S MAIN ST. CORRIDOR & HISTORIC RESIDENTIAL ENVIRONMENT

Conway's Traditional Residential Overview

Conway's in-town neighborhoods have a diverse stock of residential forms and significant architectural styles. **This section is intended to suggest consistent design standards to maintain traditional residential building forms, primarily found in the Main Street Corridor HDRD and voluntary residential CAB review. These guidelines are not intended to limit the homeowner in design; rather, to help better understand what makes the home a contributing asset to the district. These guidelines address how to treat or add unique building features while keeping what defines the architectural character of dwellings.** By following this section, each and every home can work as an individual statement while contributing to the historic district as a whole and in coordination with neighboring houses. (See map in Section A, page A.5 for historic districts.)

In addition to being the traditional center of government and commerce, to Horry County, downtown Conway is home to the city's historic residences. The street plan, a fairly rigid grid, extends west and north from the commercial center (National Register Historic Downtown District) into largely in-tact original residential districts. Main Street remains the major north/south artery through the district, and is the location of the larger residences of Conway's prosperous citizens who built two- to three-story Victorian-styled Queen Anne and Georgian houses in the late 19th century, and Neoclassical-styled homes through the 1920s. The grid is interrupted by piecemeal subdivision of larger privately held tracts of land north of 7th Ave and west of Beaty St. (outside of the HDRD and NRHD boundaries).

Some of the oldest, modest one-story traditional gable-end cottages and two-story Queen Anne Houses, I-Houses, and Georgians are east of Main Street between the downtown and the river and some west of Lewis St. on the other side of the Courthouse from downtown. Regional plantation, Colonial and some Charlestonian features can be found. The area's homes are consistently spaced with front yards, low decorative fencing, sidewalks and live oaks planted along major and minor streets creating a street rhythm typically found in South Carolina cities from this time.

Fourth Avenue, the major east-west connector from downtown to the US-501 bypass, became a 20th-century auto corridor. Early 20th-century bungalow neighborhoods were prevailed up to Seventh Ave, north of Fourth, and west of Beaty St. Mid-20th-century ranches, cottages and Minimal Traditional-styled American Small Houses are commonly found in the areas off both sides of Fourth Avenue constructed on existing vacant lots.



"Historic" homes are often the most modest homes. (Left) Some of the oldest working class homes, shotguns and gable-wing cottages are found west of downtown, throughout the in-town neighborhoods of the City, within and outside of the Conway Residential NRHD. Even the Conway Commercial HDRD has a few hall-parlor and central-hall homes, possibly from the mid- to late-1800s.



(Above) Homes in the Conway National Historic Residential district retain high- and varying-styles of historic residential form and character. Large bungalows (above left) and modest mid-20th century gable-end cottage (above right) forms make up the majority of the residential surrounding downtown with varying size and uniform setting.



A home with an urban, Charlestonian porch and form (left) is at the curve of Kingston Street, one block off downtown and across from the Waccamaw River. Also, next door is a unique gable-winged house with a Dutch Gambrel roof form (right).

Commercial areas of Conway are zoned for multi-family, however there are no "historic" apartment forms within residential sections of the local HDRDs. An example of newer construction (ca.2000 - right) multi-family in the Waccamaw Riverfront HDRD could be used as a model (plan & scale) as either in-fill in the SW portion of the Commercial HDRD (around civic) or outside the HDRD boundaries along auto corridors.



7.1. Residential Form vs. Style

While these guidelines are intended to guide the physical elements of each residential structure, two major definitions of how to “read” a building and determine its original intent must be made. Building *form* and the *style* of its architectural details are two separate subjects, and each determines how buildings would be rehabilitated, restored or reconstructed today.



Left Conway, 2009, Right Baimbridge, CA

Form is often misinterpreted with style. These two Bungalow forms share almost identical plans yet one is “Craftsman Bungalow” (left) and the other a “Mission-Revival-style Bungalow” (right).

FORM:

A residential house *form* is largely defined in plan, arrangement of its functional spaces, and sometimes its social connotation (i.e mill village, custom built or planned neighborhood). The form of a traditional residential single family home differs from that of a multi-family duplex, apartment or town home. When defining form, it may simply be the overall shape or could include the number and sizes of openings, if it is (or intended to be) single or multi-family, room layout (i.e. shotgun, central or side hall plans, as opposed to an “open” floor plan). Residential forms, as opposed to commercial, could include roof forms, the yard, porches, and possibly even attached or out-buildings. An example form description of a residential building might read:

“A single-story, gabled wing ‘L,’ cottage raised on a 4 foot high crawl-space foundation has a central hall, front parlor, 2 bedroom, 1 bath layout. Home is set on a 1/2 acre corner parcel lot with 5 foot side set back from sidewalk, 4 foot side set back with 14 foot separation from neighboring structure, and 16 foot front yard set back from the sidewalk; remaining land comprising of a back yard. The front facade of the gabled ‘L’ contains a shallow 3 part bay window with mansard roof and a covered front porch runs the remaining length of the front even with the ‘L’ facade projection.”

Predominant Residential Building Forms: In-Town Conway

- Shotgun House (1-Story)
- Double Shotgun (Duplex 1-Story)
- Side Gabled Cottage (1 Story)
- Gabled Wing Cottage (“L” or “T”)
- Pyramid Cottage (1-Story)
- New South Cottage (1-Story)
- I-House (2-Story)
- Side Hallway Townhouse (2-Story)
- American Four Square (2-Story)
- “Saltbox” (1 & 2 Story)
- Bungalow (1 & 1-1/2 Story)
- English Cottage
- American Small House
- Post WWII Ranch
- Multi-family, Multi-story Apartment (contemporary)

STYLE:

Building or architectural *style* is a matter of the intended choice of decorative embellishments and adornments that were socially driven by the fashions, pattern books and physical properties of materials and technologies of the period in which they were built. Different styles can overlap within the same time period and different styles may be applied to the same basic residential forms listed to the left, below. Architects and home owners selected the style that best defined their personality or the character of the neighborhood at that particular time.

Often, the original intended style is built into the fabric of the building through the choice of exterior cladding, the foundation material, proportions of the arrangement of elements and the shape and arrangement of openings corresponding to interior living space. Styles may be dictated by an overall, intrinsic neighborhood character especially seen in “early suburban” housing (the “revival styles” applied to Georgian and American Foursquare homes of the 1920s), or thematic housing of the 20th century and post-World War II (such as English Tudor cottages) or Williamsburg-Colonial styles of the 1970s. Style is also portrayed in the choice or necessity of certain window sash and glass divisions, door styles, applied artistic details and original intended amenities such as awnings, railings, light fixtures or hardware.

Significant Historic Building Styles: In-Town Conway

- Italianate Victorian
- Queen Anne Victorian
- Dutch Colonial
- Greek Revival
- Gothic Revival
- Georgian Revival
- Folk Victorian
- Neoclassical Revival
- Arts and Crafts (Craftsman)
- Tudor Revival
- Mediterranean Revival
- Prairie
- Minimal Traditional
- International
- Contemporary

D MAIN ST. CORRIDOR HDRD & (VOLUNTARY) RESIDENTIAL GUIDELINES

Chapter 7 BASICS OF TRADITIONAL RESIDENTIAL BUILDINGS

7.2. Common Historic Residential Building Forms

Conway's residential historic district is rich in social and architectural history. Different sections of in-town residential extend to the west and north from the central business district (see map page A.5) and relate to the function and time period of their development. This creates a broad array of residential building forms that can be found (see Section A, Chapter 1.6. "Retaining a Sense of Place and Context") Major residential forms found in the Conway district

are highlighted here. For this document the following residential building forms are grouped by their scale and identified primarily by their roof forms, stories, and house extensions. The following forms do not constitute every building type and its historic basis found in the district.

Basic "Shotgun" & "I-House" Forms

The Shotgun form is represented by a one-story residential structure, one room wide with a side hall. Rooms are lined up in front of each other. This form can be individual with a gable-end or hipped roof and also as a duplex with a mirrored plan, called a double shotgun. A one-room deep, two-story gable-end home, called an "I-House," are throughout Conway (with later additions).

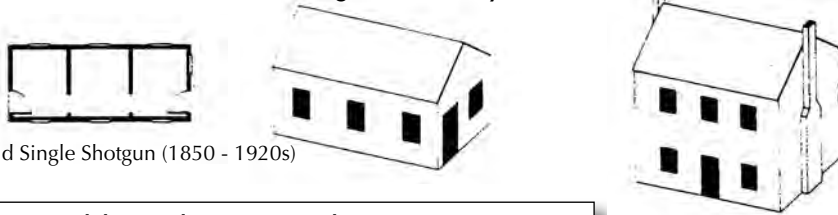

*Gable-end Single Shotgun (1850 - 1920s)

Basic Gable-End & Pyramid Cottage Forms

One of the simplest housing types in the late-19th- and early-20th-century is a square main mass, typically with four principal rooms and no hallway. **Roof forms to this house plan in Conway may be found more as a side gable than a "Pyramid Cottage."** The pyramid roof form is prevalent on homes built between 1910 and 1930 with a greater amount of roof supporting itself using a lesser amount of materials than the gable end. For wood framing, the pyramid is a strong design for the roof. All four sides of the roof tied to the home and rafters joined at multiple angles create more rigidity than a gable-end, single-ridge roof. Full length porches extended from the house mass are common.

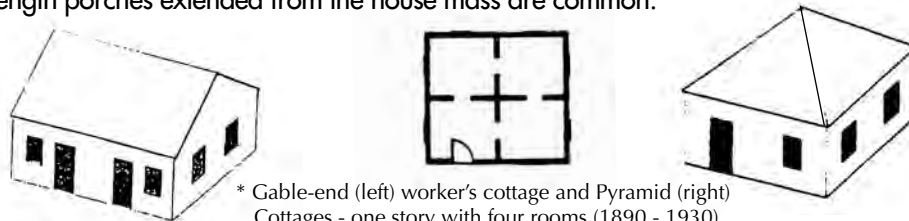

* Gable-end (left) worker's cottage and Pyramid (right) Cottages - one story with four rooms (1890 - 1930)



*Gable-end, Two-Story "I-House" one room deep, two wide with central hall (1840 - 1880s)



All Images Conway, SC 2009
Conway NRHD



Very few gable-ended, shotgun floorplan homes are in the current historic districts, however the Conway Historical Society is a good rare example (above-left). Some of these homes might be the oldest in Conway. A few Two-Story (possibly, originally one-room deep) "I-Houses" appear to exist throughout in-town neighborhoods (upper & mid right), even out near the mall (lower right).



Conway, SC: outside HDRD

Simple gable-end house forms with porch extensions make up modest and mid-sized homes (right).



Conway, SC 2010

7.2. Common Historic Residential Building Forms (continued)

BASICS OF TRADITIONAL RESIDENTIAL BUILDINGS

Chapter 7

Progression of Gable-End House Forms

Gable-end forms have been used since Conway's settlement. Two room wide and only one room deep "Hall Parlor" or "Central Hallway" homes may still be found in Conway's northwest neighborhoods or toward the back of properties. The most basic residential house form has two gable ends to the roof. When a perpendicular wing is set from one side or centered to one of the ends, the form can become a "Gable-Winged Cottage" in an "L" or a "T-plan." Interior rooms may be arranged in many ways. With the advent of balloon framing over timber frames, more open floorplans could be achieved and two-story plans grew from "I-houses," "Georgians," and two-story Gable Wing homes (much like the vernacular farmhouse). Gable-end homes have multiple styles applied through the 19th and 20th centuries and continue to be built today.



* Hall Parlor House (1800 - 1930)



* Central Hallway House (1830 - 1930)

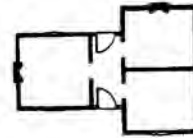

*Two-Story Gable-Winged House (1875 - 1900)

* One-Story Gable-Winged Cottage (1875 - 1915)

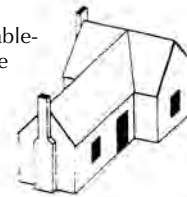

The gable-end home as a basic house form with multiple variations is prolific throughout Conway's historic districts and the entire city. A one-story gable-winged cottage (top right) is a rare urban example and may have had additions over the years. One-story, 20th century cottage forms (mid right) and ca.1920s-1940s "revival style" (3rd-down right, "Tudor revival") gable-winged cottages are common to Conway.



All images, Conway, 2009

Progression of Pyramid House Forms

Greater roof area garnered from the basic pyramid form (see pg. D.3) progressed into variations of floor plans well into the 20th century. As the middle class grew, building technology refined and home goods were made more available, formal rooms for parlors, dining and attached kitchens on common one-story homes became prevalent. The basic mass of the home under the pyramid roof expanded with a variety of hall and room configurations. Gabled wings added or extended rooms to form the "Queen Anne Cottage," while rooms arranged around a central hall with a variety of gabled wings (even flanking pairs) form the "New South Cottage." Shallow pyramid roof forms with a ridge cap are known as a "hipped" roof allowing the basic pyramid form to become extended. The "American Foursquare" is a two story pyramid house form.

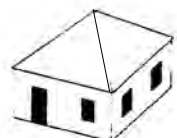

* Basic Pyramid Cottage (1890 - 1930s)

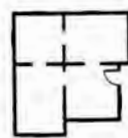

* "Queen Anne" Cottage and Two-Story Queen Anne House (1880 - 1900)

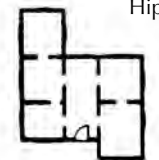

* "New South" Cottage (1890 - 1920s)

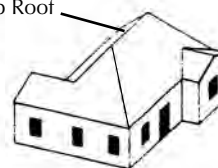

Hip Roof

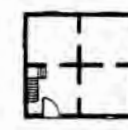

* American Foursquare (1915 - 1930)



One-story pyramid cottage house forms or pyramid roof American Foursquares are rarely found in the Conway districts. Gabled wings added to the front and side of a two-story central house mass, with pyramid roof form make up only a few, true "Queen Anne Houses."

All images, Conway, 2009

Georgian, "Raised Cottage" & House Forms

A popular residential house form in rural South Carolina is the Georgian Cottage. Not named for the state of Georgia, its single-level floor plan consisting of a central hallway with two symmetrical rooms on either side is associated with 18th century English Georgian architecture. Symmetry of the house plan and exterior elements are key. Roofs can be hipped or gabled. Chimneys are often in the interior of the house, between each pair of rooms. The same home set on a high foundation was often a more urban form. Few exist in Conway. The "Georgian House" is a two-story version of the cottage, two rooms wide and two deep in plan with central hallways. In the early 20th century a high percentage of "Georgian Revival" houses based on this type were constructed throughout the Conway National Register Historic District and the city, with many displaying a variety of styles through porch additions, porch wings and house extensions.



All images, Conway, 2009

1-story Georgian Cottages (left) are rare in Conway's historic neighborhoods (left). 2-story Georgian Houses are common and have many styles associated with them (right a Georgian House with Folk Victorian styling).

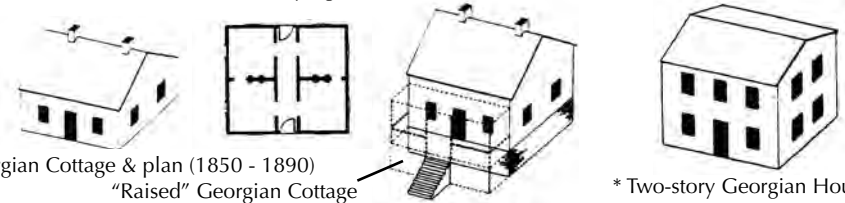

*Georgian Cottage & plan (1850 - 1890)

"Raised" Georgian Cottage

* Two-story Georgian House (1850-1860s, 1900-1930s)

Multiple Bungalow Forms

The Bungalow form is the MOST common house form throughout Conway's in-town neighborhoods. Often mistaken as a style, bungalows are a house form that have wide, low gable ends running the entire width of the front or depth of the side of the house. Based on these roof forms and variations, there are four sub-types: front gable, side gable, hip, and cross gable. A true bungalow includes a wide front porch, integrated under the roof eave or extended porch, with evenly spaced, wide (often battered), or grouped square pillars. Bungalows are usually one or one-and-1/2 stories and did not exist until the 1910s.

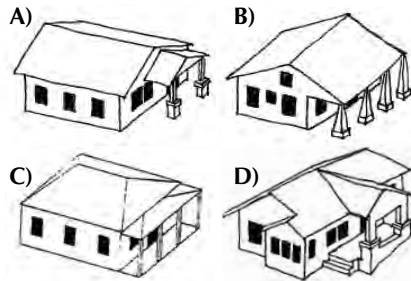

* Bungalow Sub-Types: A) Front Gable, B) Side Gable, C) Hip, D) Cross-Gable (1900 - 1930s)



(left) The front porches of modest cross-and side-gable bungalows in the Main Street Corridor. Note rhythm of front yard set back, height & mass, yet each is slightly different.



All images, Conway, 2009

Bungalows are the most common house form throughout Conway's in-town neighborhoods. (left to right) A front gable bungalow with full length integrated porch; a variation of a cross-gable, California-Arts & Craft style bungalow; and the porch of a grand 2-story side-gable brick bungalow with central gabled dormer and a mix of Craftsman & Prairie styling.

Post-WWII “American Small House” & Ranch

Early suburban planned neighborhoods make use of mass produced materials and repeated efficient floorplans, clustering bedrooms to one end of a single or split-level home. The ranch form is elongated by horizontal composition and low hipped or shallow gable-ended roofs. Early styles are refined traditional forms and later have contemporary geometric or flat roofs. “Picture windows” are introduced. Controlled landscaping, built-in planters, and refined “less-is-more” detail are common. In the early 2000s these forms are just reaching 50-years old and can be the most threatened historic resource of many districts.

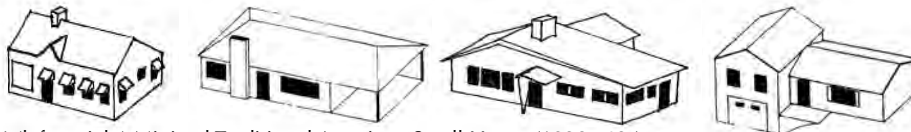

* (left to right) Minimal Traditional American Small House (1930s-40s), Hip Roof w/ Carport (1950s-), Contemporary w/ Geometric Roof (1960s-), and Split-Level (1970s-90s)

20th - 21st Century Professional/Residential

The Main Street Corridor HDRD in Conway is seeing a recent trend as a favored location of neighborhood-based professional businesses along Main Street. This has caused some properties to be rehabilitated into new uses as well as other properties to have new-build, commercial/professional in full residential form during the 1990s and early 2000s. There are pros and cons to this approach. These buildings may fit in the best, however as long as the architecture (according to the *Secretary of the Interior’s Standards* (Pg. A.11)) does not “falsify history” or attempt to “fool” the viewer that what they are seeing is old. New architecture should be differentiated from the old so Conway can be “read” in the future as to where it is growing and changing today.

Some of the historic, mid-20th century International-styled commercial architecture and highway commercial forms are important to preserve in areas like the Main Street Corridor HDRD. Their contrast has become significant to the residential forms, from a time when these were built in the highest commercial styles. This also sets a precedent that new commercial can be done in high contemporary styles if scaled to the neighborhood and sited properly.

Finally, when rehabilitations are undertaken the placement of ADA accessibility features, new signage, and parking need creative solutions.



All Images Conway, SC 2009

Post-WW II house forms are found on subdivided lots throughout Conway’s in-town neighborhoods. Off the Main Street Corridor (upper left - ca.1940 w/ enclosed side porch) blocks of American Small Houses and neighborhoods north of Fourth St (upper right - ca.1950) were planned communities. Ranch homes (lower right) in context next to each other retain many original features (low, controlled landscaping and lawns are important).



Both Images Conway, SC 2009

Commercial structures need parking. A group of new residential-form professional buildings (ca.2000) at Main Street and Ninth (above left) with cars in back and between buildings, retaining trees and siting buildings to others on the block. North of Fifteenth Ave. in the Main Street Corridor HDRD a 1950s-era building like Salley Cleaners (right) embraces the environment of faster moving traffic with fully paved lots, and larger signs as part of the mid-20th century facade design and post signs.

(right) A large, historic Queen Anne House being used for public/business purposes with a well-designed ADA-access ramp along the side accessing rear parking area for handicap patrons. Landscape hedges soften visual impact of the ramps and the Main St.-facing front yard is saved.



Conway, SC 2010

D MAIN ST. CORRIDOR HDRD & (VOLUNTARY) RESIDENTIAL GUIDELINES

Chapter 8 RESIDENTIAL RESTORATION & ARCHITECTURAL DESIGN GUIDELINES

8.1. Residential Openings and Amenities

Residential Entrances

- 8.1.1 **Preserve (retain and restore rather than replace) any original entry elements** (door configuration, depth, recessed, flush or other).
- 8.1.2 **Determine and retain or replicate, if necessary, the original entry ceiling height, door transoms, materials or placement of doors** (right, left or center facing, single, double, etc.) original to the dwelling, and/or those changes to entrances that have gained historic significance over time.
- 8.1.3 **Determine and retain or replicate, if necessary, the original entry exterior floor** (original hex tile, wood, cast iron sill plate, etc.) original to the home, and/or those changes to entry floors (terrazzo, artistic tile, mosaic, etc.) that have gained historic significance over time.

Residential Doors

Appropriate

- 8.1.4 **Preserve (retain, restore and maintain) any original entry doors.**
- 8.1.5 **Retain (and repair) rather than replace deteriorated door parts.**
- 8.1.6 **If replacement of parts is necessary due to severe deterioration, replace with features to match (accurately duplicate profiles, massing, scale) in design and materials.**
- 8.1.7 **If original doors cannot be determined using photographic or physical evidence, then provide custom replacements that are compatible with the architecture of the building.** Research the door style that best fits the home or the neighborhood. If replacement doors have glazing, ensure it is proportionate to window glass. Wood is preferred, however there are good sources for metal doors with factory colors or wood grain finish, and more reveal of trim, panels, rails and stiles.
- 8.1.8 **Door hardware, if missing on originals or on replacement doors, should be of the same architectural form and style of the home.**
- 8.1.9 **Retain later-period doors that may match significant new styling or architecturally significant upgrades to the aesthetics of the home with important history or those using quality modern materials, especially if the originals are not documented with the district.**



All images, Conway, 2009

Entry configurations have as much to do with exterior architectural style and with the original intended form as with the interior layout. A front central entrance (above) to a Georgian home with Neo-Classical styling has sidelights and small attached front porch. A central door (upper right) off of a typical deep bungalow porch, in contrast to a refined mid-20th century poured-concrete and wrought iron porch entry (right).



Inappropriate

- 8.1.10 **Do not use "French doors"** (those containing full face of multiple divided glass panes) or full glass sliding doors for a front entry door. They are appropriate for use on a side porch or patio. (See Figure 4.2)
- 8.1.11 **(Potentially inappropriate, see Figure 4.2 (E)) Solid wood doors with geometric or small glass insets may only be appropriate on mid-20th century ranch or contemporary forms.**
- 8.1.12 **For multi-family structures, apartments or residential conversions/additions, do not immediately remove original historic doors.** Check with local code official for saving historic material and building egress compliance.

Fig. 4.2: Illustrated Examples of Traditional Residential Doors

APPROPRIATE:

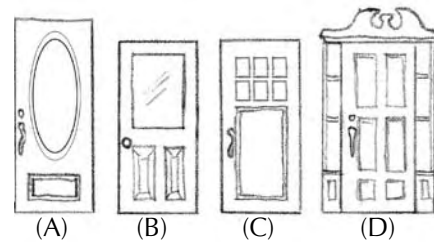

INAPPROPRIATE:

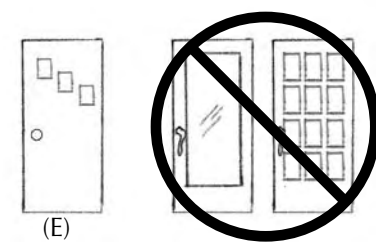

Typical (yet not limited to) residential door examples for: (A) high-style Victorian, (B) folk Victorian, cottage, mill house, or late-19th century vernacular, (C) Craftsman-style, (D) Neo-Classical or classical revival with side lights and trim, and (E) potentially and only appropriate on mid-20th century homes if evidence of similar door styles are in neighborhood.

8.1. Residential Amenities (continued)

Residential Windows & Fenestration

Appropriate

- 8.1.13 **Preserve (retain, restore and maintain) any original window material.** Specifically address the integrity of window glazing, profiled framing, or wood stops that secure the lights. These items are exposed to normal weathering and UV light and intended to be periodically maintained.
- 8.1.14 **Retain (and repair) rather than replace deteriorated window parts.**
- 8.1.15 **If replacement of single units are necessary due to severe deterioration move "same fit" original windows from rear to street-facing openings or replace with custom sashes to match (accurately duplicate profiles, massing, scale, reveal) in design and materials. Wood is preferred.**
- 8.1.16 **If sash weights and weight pockets still exist, these historic features should be retained, rebalanced or repaired. If these pockets are no longer used, insulate with fiberglass batting, which is reversible. Do not fill with expanding-foam. Some historic windows have been retrofitted with aluminum compression channels rather than sash weights or have had these installed over the years; assess their integrity to potentially restore the weights. Use chain, wire or natural rope that will not degrade in UV light to replace cords.**
- 8.1.17 **If original windows cannot be determined using photographic or physical evidence, then provide custom replacements that are compatible with the architecture of the home. Replacement windows should have glazing proportionate to the opening with mullions (generally deeper profiles) that are true-divided panes per sash. All surfaces must be paintable.**
- 8.1.18 **Assess the mechanics of each window and repair as needed.** Window hardware, if missing on original windows, should be of the same architectural form and style of the window units.
- 8.1.19 **Use exterior storm windows as intended, or new interior magnetic snap-in units with screens. Online vendors at a fraction of replacement cost.**
- 8.1.20 **Retain metal windows if they are original.** There are certain styles of homes in the Art Deco, Art Moderne or Contemporary periods (1920s, 30s, 50s, respectively) when metal casement or jalousie windows with painted steel or anodized finishes were used. These have thin mullions with sleek profiles.
- 8.1.21 **Shutters must be operable and sized so if closed they will appropriately cover the window opening and meet in the middle.** Some mid-20th century home styles used fixed, faux shutters as decoration.



All images, Conway, 2009

Windows are significant character defining features to the form, style and technology of a historic home. (Left) Windows of all shapes, sash styles and sizes are eclectic and custom fit to the Queen Anne Victorian taking in a great deal of light pre-electricity, while (right) the modest (horizontal mullion) double-hung sashes (matched to align side windows to the "picture window") are equally as important to save on this Post-WWII 1940s American Small House.

Inappropriate

- 8.1.22 **Do not remove, replace, reduce, cover or alter original windows.**
- 8.1.23 **Do not sandblast** or use any abrasive method to clean or strip, including high-pressure water. Use only gentle, restoration-sensitive chemical cleaners and strippers or mild detergents and natural bristle brushes.
- 8.1.24 **Do not install smoked, mirrored or tinted window glass** as this is highly out of character for a traditional residential environment. For sun protection, traditional in-town neighborhoods benefit from tree canopy, interior blinds and many home styles support decorative awnings.
- 8.1.25 **Do not install thick insulated glass in original frames,** as it is incompatible with most original trim work configuration. Glass can be ordered and set back into traditional wood framing if the field of glass needs replacement. Generally insulated glass will do no more good than interior sun-screening devices, and gas filled, double-insulated glass is prone to leaking.
- 8.1.26 **Avoid replacing historic windows with off-the-shelf replacements** or new windows. Moisture and condensation is normal to a degree on single-pane glass, and the source of moisture could be from an over-humidified or over-insulated interior atmosphere. Use storm windows (see #8.1.19) to control air inefficiencies of older windows.
- 8.1.27 **Avoid vinyl, plastic or fiberglass parts** as these are not of a historic nature and can degrade quickly in UV light.
- 8.1.28 **Grid-between-glass or "snap-in" flat vinyl mullions are not allowed.**
- 8.1.29 **Do not use new glass if it requires new frames that cannot match the old in placement, width, or profile (thickness for shadow lines).**

Residential Lighting

- 8.1.30 Preserve original light fixtures where they exist.
- 8.1.31 If replacement is necessary, use fixtures appropriate to the period of the residence.
- 8.1.32 Conceal or recess contemporary wall or ceiling-mounted fixtures such as ceiling fans, yard lights, or motion sensors, or color coordinate these fixtures to "blend" into the home.
- 8.1.33 Do not automatically choose "Williamsburg" or Colonial-type fixtures on a home which would not have used this style. Choose fixtures in context of the period and intended styling of the home.
- 8.1.34 If desired, use security lights or architectural lighting "washes" where desired, however aim toward the structure or at the rear of the house and keep these lights on dimmers or timers.

Research original lighting or choose reproduction lighting to compliment the architectural style of the home. Shown here are a Craftsman-styled hanging porch light (left) and a re-production Colonial-revival gas lamp (right) for example only.



Rejuvenation "Craftsman" (left) and Charleston (right) Lighting



Conway, 2009

8.2. Foundations, Piers and Crawlspaces

Architectural Materials

- 8.2.1 Preserve (maintain or restore, not enclose or alter) original porch and house foundation materials and design, whether they are solid or pier, brick or stone, etc.
- 8.2.2 Use lattice panels (preferably of 45 or 90 degree angles with minimum 1/2-inch-thick wood strips and square openings no more than 2 inches) or vertical wood slats where needed between foundation piers.
- 8.2.3 Ensure grading and landscaping shed water away from the foundation. If water infiltration is an issue from gutters or run-off toward the home install a French drain system along the foundation and carry water away from home and out into the property or to a curb.

(See also Section D, Chapter 8.4 "Masonry Walls" for more on actual material treatment and maintenance. Also see Section D, Chapter 8.3 (next page) on "Porches."

Foundations of exposed material visually and physically raise the home on its setting. Generally they are a masonry material or consist of a frame home set on brick piers. This shows brick foundation has landscaping appropriately trimmed back from the base. (Note decorative lattice to vent porch/crawlspace and keep animals from crawling underneath.)



Conway, 2009

This brick pier foundation with lattice covering was applied to relatively recent (ca. 2000) residential construction within the Conway Residential National Register District.



JB+a Photo Archives, 2008

8.3. Porches

Traditional porches encourage social interaction in neighborhoods. In a historic neighborhood the porch is one of the most dominant features of traditional residences, comprising 60% to 90% of the facade.

- 8.3.1 **Preserve (maintain or restore, not alter or remove) original porches** and features, including location, outline, height, framing and detailing.
- 8.3.2 Do not enclose or "condition" historic front porches with permanent walls.
- 8.3.3 Enclose rear or side porches only with removable, temporary panels and maintain "open feel" and features of porch framing in front (Fig 4.3).
- 8.3.4 Do not redesign or re-locate porch steps other than in original position.
- 8.3.5 If porch and architecture supports decorative awnings (fabric) and/or canopies, use to enhance shade during the day.

(Use all of Chapter 8.3 for review in Commercial and WRD HDRD porches.)

Construction, Enclosures & Connection

Appropriate

- 8.3.6 **Preserve (retain, restore and maintain) any original porch enclosures.** For enclosed or screened porches, address the integrity of window glazing, profiled framing, screen doors exposed to weathering and wear that are intended to be periodically maintained.
- 8.3.7 Preserve railing construction, only adding balustrades where none existed for safety using material and design compatible with the house.
- 8.3.8 If replacement of parts is necessary due to severe deterioration, replace with features to match (accurately duplicate profiles, massing, scale) in design and materials.
- 8.3.9 **If original porches cannot be determined using photographic or physical evidence, then provide a design that is compatible with the architecture of the building and/or in keeping with similar structures in the adjacent residential area.** Generally, replacement trims, decking, and railings should be proportionate to the original home. Wood framing is preferred for most residences unless original porch was brick, stone or mid-20th Century style originally used concrete, terrazzo or metal railings.
- 8.3.10 Retain later-period porches that match modern changes, additions or upgrades with significant architectural history.
- 8.3.11 Screen walls are permitted as long as installed to the inner plane of the architectural columns and behind balustrades to retain visible elements.

Fig. 4.3: Properly Enclosed Porch

APPROPRIATE:



This side porch (not in Conway) was enclosed using interchangeable clear glass or screens with wood framed divisions behind columns. The entire enclosure system is set behind the balustrade and posts.

INAPPROPRIATE:



This house (not in Conway) has full front porch enclosed with permanent walls, inappropriate windows and clapboard siding where open porch railings should be. This alters the form of the home dramatically.

Both images: JB+P Photo Archives

Inappropriate

- 8.3.12 Do not remove, replace, reduce, cover, or alter original porch material.
- 8.3.13 Do not permanently enclose and create "conditioned space" of any architecturally significant porch without the change being made so that it is "reversible" to, and giving the appearance of, the original, open porch. Use full sheets of glass for the opening size (Fig. 4.3).
- 8.3.14 Do not sandblast or use any abrasive method to clean or strip, including high-pressure water. Use only gentle, restoration-sensitive chemical cleaners and strippers or mild detergents and natural bristle brushes on wood or brick.
- 8.3.15 Do not install permanent window glass in replacement for, in front of, or encapsulating existing porch elements.
- 8.3.16 If original enclosed "sun porch," do not install "stylized" residential windows where temporary panels were intended. Avoid divided light sashes or plastic (grid-between glass) window frames incompatible with house style (see Fig. 4.3) and generally choose darker hue or paintable frames than white. Original enclosed porches often intended for "weatherization" with storm windows and removable screen units. Use interior magnetic snap-in storms with screens. Look for pintles and original hardware to attach units. (Interior sun-screening devices are proven to be as effective as insulated glass.)

Columns & Millwork

- 8.3.17 **Preserve (maintain or restore, not remove, cover, or alter) architectural decoration** such as brackets, dentils, gingerbread, "fish-scale" shingles, window hoods and lintels and trim work or molding.
- 8.3.18 **If original columns do not exist, replacements can be ordered in contemporary materials such as fiberglass-reinforced-plastic (FRP) however ensure that the finish is capable of applying paint, manufactured seams are not dominant, and the scale in diameter or width is adequate for the porch and the scale of the home.**
- 8.3.19 Replace missing columns or millwork based on accurate duplication or close visual approximations of the original. Historic photographs are a primary reference source.
- 8.3.20 Do not introduce or substitute any columns of any style not original to the building.

jB+ra Photo Archives



The simple or ornate style of the home is often reflected in the columns and porch details. Square, fluted wood columns set on brick piers are traditional of the Folk Victorian style home (above left), "battered" columns of a Craftsman-style bungalow (above right), or full-height wood grouped columns of a low side porch without railings (right). Note how other homes and yards can be seen through porches.



Conway, 2010



Conway, 2010

Coverings, Eaves & Porch Roofs

- 8.3.21 **Preserve (maintain or restore, not alter) original porch roof shape and pitch, eaves, rafters, overhang and connection onto the home.**
- 8.3.22 Maintain original size and shape of dormers if present.
- 8.3.23 Do not add dormers where none existed originally or to portions of the roof that are visible from the public right-of-way.
- 8.3.24 Generally porch roofing materials match that of the main roof system. Retain matching roof materials where possible.
- 8.3.25 **Standing seam metal is appropriate on a few types of buildings,** usually a vernacular farm-house, industrial shed or 19th-century cottage.
- 8.3.26 **If replacement is necessary and roof covering is proven to not be made any longer, substitute an approved "architectural" compatible roofing material upon the age and style of the home.** New, composite shingles are built-up to gain a look and dimension of materials like slate or shake, in many colors or earth tones. Recycled rubber products, formed into slate shapes are installed in the same manner and fiberglass replacement terra-cotta are options. Stamped metal is still available today.
- 8.3.27 Preserve the underside materials of porch ceiling.

APPROPRIATE:



Conway, 2009

Deep porches and coverings protect the home from harsh South Carolina sun and rain and extend living space outside. This porch along N. Main Street has a bead board ceiling painted a traditional light blue (in folk lore this "haint blue" allowed "spirits to move on" if they got trapped on a porch).

INAPPROPRIATE:



jB+ra Photo Archives

This bungalow (not in Conway) has the full length front porch enclosed. Aluminum awnings from a later time period than the home have been added, as well as an aluminum car-port cover extension to the side in the front yard. These are essentially cosmetic modifications easily uncovered.

8.4. Exterior Walls and Insulation

- 8.4.1 Preserve (maintain or restore, not alter or remove) original siding material and features of the siding up into the gable ends including location, outline, height, roof pitch and detailing.
- 8.4.2 Generally wood, brick, masonry or stone are considered the most appropriate materials on historic homes in the district. Beyond aesthetics, modern manufactured products applied to historic framing and surfaces may permanently off-balance the intended vapor transmission and moisture levels, and increase the deterioration rate of most historic natural materials.
- 8.4.3 If the original or historically-intended siding (material and pattern) is repairable and/or "healthy" then it is not recommended to remove, replace, reduce, cover or alter the siding material on historic homes.

Siding, Clapboard & Gables

Appropriate

- 8.4.6 Maintain the longevity of the painted material. Use mild detergent, a soft bristle brush, and hose pressure rinse to clean. Regularly scrape, sand, prime and paint small patches of flaking paint. Raw wood siding can be treated with natural oils before re-prime and painting.
- 8.4.7 Retain (and repair) rather than replace deteriorated siding elements.
- 8.4.8 If full replacement of siding or features is necessary due to severe deterioration, disaster, use "like" material to fix or move all good historic material to public elevations. On new construction or new additions, contemporary-compatible materials (fiberglass-reinforced plastic (FRP) details or approved cement fiberboard only) that match the old in profile, design, texture, installation, and other visual qualities may be used.
- 8.4.9 When painting, a traditional color scheme is generally no more than three colors. Neutral or earth tone hues are recommended for the "field" of siding, with trim, eaves, and framing color to compliment and contrast.
- 8.4.10 If original siding cannot be determined using photographic or physical evidence, then provide custom replacements that are compatible with the architecture of the building. Generally, replacement trims, clapboards, shakes, stucco patterns, or bricks should be proportionate to the original and/or surrounding homes. Wood framing is preferred.
- 8.4.11 Stylized scallops and decorative siding may be appropriate if precedent for applique is a historic feature of the same style of neighboring properties.
- 8.4.12 Ensure earth and foliage have the least contact with wood siding and sills.

- 8.4.4 Ensure any changes to exterior walls are reversible to the historic surface.
- 8.4.5 Older walls MUST breathe. Insulation should not be at the expense of filling wall air space (that will trap moisture and can breed mold) or with irreversible adhesion (such as foams). Fiberglass batting below floors and above ceilings, as well as rigid reflective foam panels under roof, plus storm windows will cut air infiltration through floors and walls. (See Appendix IV.3)



Conway, SC NRHD, 2010



jB+a photo archives, 2007

Siding generally continues from the bottom sill (at the top of the foundation) up into all gables, shown here on a large Conway bungalow with alternating wide & narrow clapboard reveals (left). An example of high-style "Queen Anne" Victorians (right) can change pattern and/or material with each level. "Folk Victorian" cottages may also have patterned gable ends.

Inappropriate

- 8.4.13 Do not install synthetic siding products (vinyl, aluminum, Exterior Insulation Finishing Systems (EIFS)) on top of, as a "fix," or to "enhance" historic wood siding, stucco or brick.
- 8.4.14 Do not sandblast or use any abrasive method to clean or strip, including high-pressure water, on any type of historic exterior surface. Use only gentle, restoration-sensitive chemical cleaners and strippers or mild detergents and natural bristle brushes. (Also see Appendix IV.2.)
- 8.4.15 Do not use water sealants or penetrants on historic wood or brick. If material is damaged and requires sealant, only use those recommended for the treating older materials that come from a qualified restoration chemical distributor, on that area. (Also see Appendix IV.2.) Ensure moisture is not originating from "rising damp" in the foundation, mechanical problems or roof leaks.
- 8.4.16 Chemical "fixes" are not recommended to repair or replace siding, treat walls or wall cavities of historic homes. (i.e. expandable foam, penetrants, "vinyl paint," spray-on adhering insulation, not in existence to original construction and not reversible to the historic wall systems (See 8.4.5).
- 8.4.17 Do not paint un-painted natural historic brick or stone.
- 8.4.18 Do not use mechanical fasteners such as nails or screws that will corrode or cause corrosive reaction when in contact with materials.

Masonry Walls & Applied Coatings

Building walls are the most over-looked mechanical system of a historic building. Built before air conditioning and to react to moisture or heat, air space within historic walls serves as insulation as well as “breathing” space for the building. Soft, historic materials are intentional and necessary for expansion and contraction and will be damaged quickly by moisture “wicking” upwards in the wall system. Known as “rising damp,” this phenomenon is worsened by later applications of exterior stucco, multiple coats of latex paint on exterior walls, and modern brick sealers on interior walls that have had their plaster inappropriately removed.

NOTE: If the interior plaster walls are showing weakening and paint damage, look for exterior causes first. Water infiltration in the form of “rising damp” from high water tables or dampness in foundation may require exterior foundation French drains to divert water. Leaks in the roof or structural stresses due to wall removal, or remodeling over time go unnoticed for years. Problems in load-bearing masonry walls should be addressed first.

Appropriate

- 8.4.17 **Ensure no water infiltrates the walls and that ground water is diverted away (above and below ground) from masonry foundation and piers.**
- 8.4.18 **If the exterior masonry is painted, and the paint layer on the substrate is stable, repainting the exterior is appropriate. Chemically removing paint rather than adding new paint is preferred, as it benefits the health and original appearance of the brick.**
- 8.4.19 **If replacing or repairing brick, make sure that the characteristics of any new brick match that of the old (size, shape, porosity, surface finish), not only for the building style but also to relate with the shrinking and swelling of the entire historic masonry system. (See Appendix IV.2. “Preservation Briefs” for information.)**
- 8.4.20 **Use Siloxane-based masonry sealants, if needed, as they have a chemical structure with a larger molecule that will still protect but not embed deep into the pores of masonry and stop vapor transmission.**
- 8.4.21 **Respect certain styles of homes in the area such as Craftsman, Art Moderne or Contemporary periods (1920s, 30s, 50s, respectively) that use smooth stucco, engineered brick and cast-in-place concrete.**

Historic brick is softer in nature due to materials and firing technology of brick. Older brick expands and contracts greatly, therefore mortar often MUST be soft. Portland cement mixes may cure quickly but they are much too rigid for the movement of the brick. This corner was pointed with improper, hard mortar and will eventually entirely fail.



Portland Cement-based stucco was a historic material applied to many wall surfaces in the early 20th-century in both original design and as a cover-up for failing masonry. This material should be assessed if it is an added layer or if the stucco was original to the building style.



Inappropriate

- 8.4.22 **Do not paint, add water sealers or apply clear coating of any kind to the unpainted masonry surfaces. These will change the “breathable” nature of the wall system, perhaps permanently.**
- 8.4.23 **Do not sandblast or use any form of abrasive, highly detrimental cleaning method (including high-pressure water) on walls. Use chemical strippers and cleaners formulated for the soft historic material that will not break the outer “crust” of old brick or patina on stone.**
- 8.4.24 **Do not repair or re-point masonry with harder (Portland cement) based mortar or contemporary engineered bricks, unless the home originally used this (generally circa 1940 forward). These materials will be too hard and rigid for softer (lime and sand based) composition of historic mortar and masonry, and will cause permanent irreversible damage to the brick wall. Find a qualified mason who is knowledgeable in lime and lime putty mortars.**
- 8.4.25 **Do not uncover a past problem. Some exterior surfaces may have had covering or application of veneers or stucco for maintenance reasons long ago such as poor masonry, a fire which compromised the brick, or natural disaster. Research the history if covering or veneer exists.**

8.5. Roofs and Roof Lines

- 8.5.1 Roofing takes the most abuse from the elements. It is expected to be replaced, yet maintained. The more a roof costs is generally the longer it will last. Slate can last at least a century, metal 50 to 80 years, and other materials less in age. The longevity of materials should match that of the historic home resulting in much added value to the property.
- 8.5.2 A general rule for roofs and roof lines is to assess what is seen from the public right of way and preserve the basic form of the roof system (flat, pitched, gabled, arch, etc.) and materials.
- 8.5.3 Preserve (maintain or restore, not alter) original main roof shape and pitch, eaves, rafters, overhang, and connection onto the home.
- 8.5.4 Maintain original size and shape of dormers if present.
- 8.5.5 Do not add dormers on building fronts where none existed originally.

Shingles & Covering

Appropriate

- 8.5.6 Maintain the longevity of the original material if it is of a quality such as slate or metal where individual sections can be repaired.
- 8.5.7 **If replacement is necessary and roof covering is proven to not be made any longer, substitute an approved "architectural" compatible roofing material upon the age and style of the home.** New, composite shingles are built-up to gain a look and dimension of materials like slate or shake, in many colors or earth tones. Recycled rubber products, formed into slate shapes are installed in the same manner and fiberglass replacement terra-cotta are options. Stamped metal is still available today.

Inappropriate

- 8.5.8 Do not use roofing material of different color or composition than what has a visual appearance of what would have been originally used.

Roof Pitch

- 8.5.9 **Retain intended roof pitch. This is an important feature that greatly identifies the intended style of the historic home.** Older homes often depend on the high attic space for proper ventilation. In planned subdivisions or districts with a common builder, changing the pitch on one home can visually affect the entire block.

This handsome Shingle-Style side-gable two story bungalow has wide eaves that denote construction technology of the time a home was built. The chimney puncturing through the eave is unique.



Conway, 2009

Recent (2000s) commercial construction along the Main Street Corridor is a good example of good infill. Roof lines and roof forms tie into surrounding residential neighborhood blocks. Materials and eaves are refined and obviously contemporary to not "falsify" history. Overall height generally conforms among neighboring homes.



Conway, 2009

Stamped metal shingles are an appropriate, long-lasting, and quality material for some late 19th and early 20th century houses and churches



JB-a Photo Archives

Chimneys, Eaves & Parapets

- 8.5.10 **Preserve (maintain or restore, not remove) original chimneys** following masonry repointing and cleaning guidelines for repairs.
- 8.5.11 Do not use metal chimney caps, rather use clay, slate, or stone.
- 8.5.12 **Preserve (maintain or restore, not remove, cover, or alter) the eaves and architectural decoration such as brackets, dentils, gingerbread, caps, flashing and trim work found along the roof edge.**
- 8.5.13 **Replace missing eave trim and millwork based on accurate duplication or close visual approximations of the original.** Historic photographs are a primary reference source. Match to the original material.
- 8.5.14 **Some gutters can become an architectural feature.** Repair or replace broken gutters in kind. Half round copper gutter was a common material prior to aluminum. Many wide-eaved roofs do not require gutters.

D MAIN ST. CORRIDOR HDRD & (VOLUNTARY) RESIDENTIAL GUIDELINES

Chapter 8 RESIDENTIAL RESTORATION & ARCHITECTURAL DESIGN GUIDELINES

8.6 Residential Yards

The yard is a common feature to the residential setting, but also found in the outer ring of city blocks of the Conway Commercial HDRD, including the "government & civic sector" character area. Green space in these areas occurs on each property between, farther set back, structures and sidewalk, generally for the enjoyment and relaxation of the resident. However, a front yard's link to all neighboring lots and repetition becomes a character defining element for a "neighborhood" as a whole. Single family homes will generally have their own yards to the front, back and side of the home, up to the property line, while duplexes or multi-unit properties may have joined yards or segmented areas of the general property. Yards are also intended for the growth of mature trees (i.e. Conway's historic Oaks) to keep property shaded and to contribute to the overall benefit of the area. The physical treatment of the yard, visible to the public, should be considered as an extension of the style of the home with common "built" elements such as retaining walls, walks, fences and drives reviewable by the CAB.



Front and side yards, driveways and a system of city sidewalks are found throughout Conway. (two above) Raised and sunken retaining walls are significant features along the Main Street Corridor. (Right) Natural yards, intentionally left rustic rather than formal controlled gardens, are not common for the public facing yards in most of in-town Conway.



Both Images, Conway, 2008
JB+a photo archives, 2007

Landscape Features & Surfaces (& Parking)

- 8.6.1 Make landscape features (personal amenities, lighting, sidewalks, plantings, etc.) visually compatible with the building and neighborhood by protecting mature trees and including lush foliage (i.e. engineered or natural composition, ALSO see Conway UDO Article 9).
- 8.6.2 Construct free-standing gazebos, pergolas, fountains or decks mainly in rear yards.
- 8.6.3 Assess whether exterior surfaces or walks outside the home should be designed with engineered (concrete), traditional (brick, slate, hex, timber, or pavers), or rustic/natural (gravel, clay, or chip) as it would fit with the style of the home and within the surrounding neighborhood.
- 8.6.4 Avoid the use of ponds or water features in front yards unless there is historic evidence of one previously existing. If water features are used in rear yards, ensure that they have a system of movement so water does not become stagnant.
- 8.6.5 Install shade and decorative trees as much as is possible for the yard - check with applicable city codes for species to use or avoid.
- 8.6.6 Use permeable surfaces such as grass and gravel as much as possible. Avoid lot coverage with concrete and adding driveways where none existed.
- 8.6.7 Do not park vehicles or construct parking pads in front yards.

Fences, Steps, Retaining Walls & ADA Ramps

- 8.6.8 **Preserve original retaining walls and fences where they exist.**
- 8.6.9 Add iron fences only in yards where appropriate to the neighborhood.
- 8.6.10 Add wood picket fences, in front or side yard facing a public street of any period building, that are stained or painted, no taller than 42 inches, and with pickets spaced generally 1-1/2 to 4 inches apart (unless city code requires more stringent spacing).
- 8.6.11 **Use flat wood board fences, no taller than 6 (six) feet tall, only around rear yards, with foremost sections located no closer to the front façade than approximately half distance between the front and rear facades.**
- 8.6.12 Do not use chain link fences unless the character of a mid-20th century neighborhood or home style allows. If use of a chain link fence is found to be appropriate and is necessary, use only in the back yard and in dark green or black to "blend" into landscape.
- 8.6.13 Do not use freestanding or "dry laid" walls.
- 8.6.14 **If an ADA ramp must be constructed to access a home, make every effort to do so at side or rear. Do not remove or alter any historic built-in features of, or anchor ramp into, the structure unless construction is totally reversible to the original architecture. Construct the ramp to be as freestanding as possible, using compatible materials of the home.**

8.7. Commercial Adaptive-Use & Sign Placement

The Conway Main Street Corridor Historic Design Review District has many homes that have been converted to business, professional or office use. When this occurs, many new factors, from patron parking to signs and advertising are introduced to the residential environment (and aesthetic). The illustration below gives suggestions on how to best use the yard and portions of the traditional house for commercial conversion.

Fig. 4.4: Properly Added Residential-to-Commercial Features:

Shaded areas & highlights suggested for commercial conversion as example only.

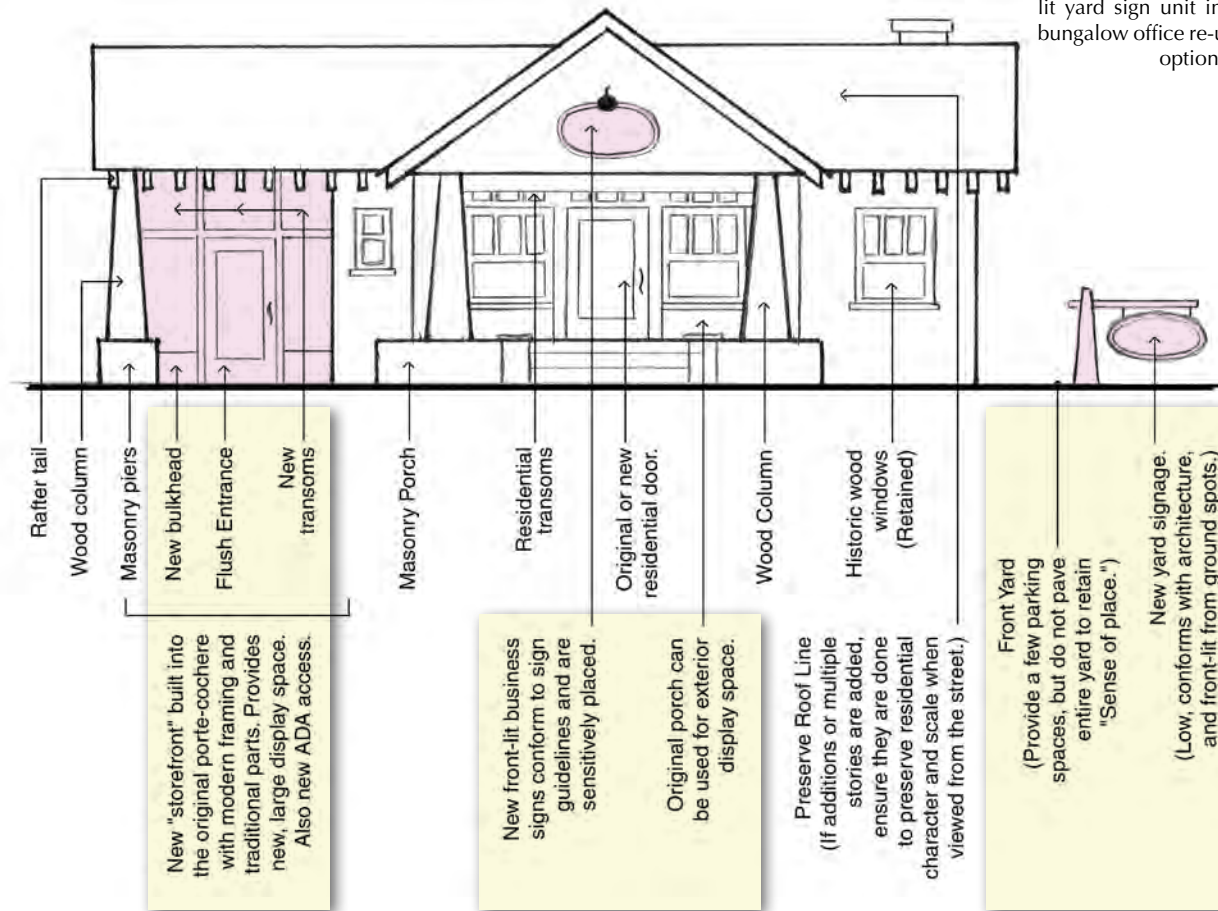

(Two above) A coordinated, and well-scaled, set of home yard signs in the Conway Commercial HDRD.

Simple, contemporary, stenciled backlit yard sign unit in front of a historic bungalow office re-use at dusk is a good option avoiding light spill.



(above) Conway Main Street Corridor yard sign properly scaled and placed in front of bungalow converted to retail use. This does not compete in the residential character of the district.

(below) A "grandfathered" auto-oriented sign in the Main Street Corridor HDRD from the mid-20th century in good condition. New signs like this would no longer be permitted in the local HDRD.



Conway, SC 2010

JB+a Image Archives

Conway, SC 2010

Conway, SC 2009

8.8. New Residential Construction

New in-fill development or new construction to replace a structure that has been lost should continue the established pattern of the neighborhood environment (generally taking in consideration the remainder of the block to each side and what is directly across the street). See Section D, Chapter 7.2 "Common Residential Building Forms" for guidance on choosing the correct roof and building combination.

(Note, new "traditional neighborhood development" outside Conway historic district (2008) excellent example.) Roof lines and forms often keep residential block-faces or groups of homes built at the same time (or by the same builder) in context to each other. Eaves, verge-boards, pitch, and overall height generally conform among neighboring homes. Front porches and yards "greet" the sidewalks.



Conway, 2009

Compatible Placement, Construction & Materials

8.7.1 **Align new construction with the front and side yard setback with the existing structures in the adjacent neighborhood by either:**

- A) Setback even with all other homes if there is a developed pattern to the neighborhood or complex of dwellings, or
- B) if the established pattern is a random setback, take the average setback of all original homes (excluding new additions) in that block face using a common line (street or walk).

8.7.2 **Build "contemporary compatible" construction where construction can be easily identified as new but the form is in context.** Avoid exact replication of previous house forms unless the reconstruction is on a highly significant landmark based on documentation and plans of the original, otherwise this would be "creating false history."

8.7.3 Contemporary materials used on new construction should be consistent with the appearance and application of traditional materials on existing structures in the adjacent neighborhood. (i.e. Materials such as cement fiberboard siding is acceptable where wood is predominant.)

Matching Scale and Form

8.7.4 **Foremost, design new construction in the same residential form consistent with the established patterns of the neighborhood** - if there is a traditional mix there is leeway to design in a contemporary form (see also #8.7.11).

8.7.5 **Design the roof form to be consistent with adjacent structures.**

8.7.6 **Limit the number of stories of new construction to be equal to or compatible with adjacent homes on either side.** The CAB may reserve the right to deny additional stories if the home appears that it will be out of scale with the building forms in the surrounding residential area.

8.7.7 Design the new construction to be of similar height, width, and proportions of existing structures in the adjacent neighborhood, taking in consideration:

- A) Foundation height;
- B) Floor to ceiling height;
- C) Use of porches (in depth, height, massing, columns)

8.7.8 Design composition and arrangement of parts (shapes, sizes, placement of windows and doors) to be consistent with existing homes.

Use Contextual Style

8.7.9 Design the characteristics and placement of exterior decoration on new construction to recognize details of existing structures in the adjacent neighborhood, if there is an established style to the neighborhood.

8.7.10 Avoid reproduction of styling which is too faux, such as using all old materials to build a new home, creating a "false sense of history."

8.7.11 In a neighborhood of traditionally mixed styles of homes, after conforming to placement and scale, one may choose to apply a contemporary style (using newer materials) to completely new construction, as long as the CAB feels it is compatible with the surrounding area.

8.9. New Residential Additions

When constructing an addition to a historic home, it is important to realize that many historic buildings cannot support additions. Often, to get the desired addition major reconstruction of very significant features is required. Adding these major building features, much like removal of small features, has the potential to degrade the historic residential environment. A building's structural integrity and the height, scale and massing of surrounding buildings are paramount when determining whether a dwelling can support an addition.

Views from the Public Right-of-Way

- 8.8.1 If small roof rooms, decks, cupolas, skylights, mechanical screening, or egress structures are added to residential structures, ensure they are not readily visible from public streets, prominent pedestrian viewpoints, or scenic vistas. The CAB may require illustrations showing the additions as they would be seen from other vantage points and will suggest the appropriate scale of additions to roofs.

Home Additions in Context

- 8.8.2 If additional square footage is necessary, designing the new addition to the rear of the structure is preferred to adding another story if space is available to the rear of the building. This will not interfere with the original form of the home as seen from the public right-of-way.
- 8.8.3 Inset new walls from the corner and lower roofs when framing additions from the sides of the home, allowing the original form of the historic structure to be "read."
- 8.8.4 Use of new construction material is permitted and welcome. Offset board or brick pattern slightly. Being able to differentiate the new from the old is important.
- 8.8.5 Ensure that the characteristics of additions continue those of the original architecture (massing, height, rhythm of openings, and general type of materials), with the goal of complimenting the existing building style as well as the existing homes in the adjacent neighborhood area.

This side addition to the historic gable-end has been done in a consistent manner to the form of this home in a National Register District. It uses a gable end, not dominating the architecture, matching the foundation height with a slight visible variation in height, and using new windows with identical divisions (yet with no shutters).



jb+ Photo Archives, 2006

(Right) Close-up of the same home (shown above) and the materials, differentiated new to old. Siding (new to the right) is separated by a vertical strip of trim and is contemporary fiber-cement compared to the original wood.



jb+ Photo Archives, 2006

Residential Rooftop Additions

Adding to (or preferably into) roof areas can be a functional way to increase space or add living space to residential rehabilitations in established neighborhoods. Locate roof & height additions toward the rear.

Appropriate

- 8.8.6 Ensure roof additions or connection into existing roofs do not adversely alter water run-off.
- 8.8.7 Use a like form of roofing material.
- 8.8.8 Ensure loads are positioned over load-bearing interior support.

Inappropriate

- 8.8.9 Do not add full floors as rooftop additions. This permanently alters the original building form.
- 8.8.10 Do not add through roofs just for expanding interior ceiling height.
- 8.8.11 Do not remove important structural members of the building to build in new roof access - choose an interior room to construct stairs.
- 8.8.12 Do not add dormers to roofs facing public streets where none originally existed, or sides that extend to meet the plane of the primary walls below, extend past beyond the eaves, connect to or extend higher than the ridgeline of the original roof (i.e. "float" the dormer in roof plane).

SECTION E

WACCAMAW RIVERFRONT HISTORIC DESIGN REVIEW DISTRICT GUIDELINES

Chapter 9:

Basics of the Historic Riverfront
Environment

Chapter 10:

Waccamaw Riverfront Rehabilitation and
Architectural Design Guidelines

Introduction

Conway Historic Design Review Districts (Commercial, Waccamaw Riverfront and Main Street Corridor HDRDs) contain a diverse stock of building forms and significant architectural styles. This section is intended to set consistent design standards that maintain the traditional river-warehouse and riverfront commercial building forms in the Waccamaw Riverfront HDRD. Design Guidelines are not intended to limit creativity. Rather, they are created to help building owners and/or proprietors understand unique building features that largely define the appropriate arrangement of traditional building details and placement of architectural amenities.

The purpose of this district is to help increase the economic vitality of the downtown, enhance the riverfront approach, provide opportunity

Waccamaw Riverfront District (WRD) Overview

Conway's Waccamaw Riverfront District (WRD) is perhaps the most individual, character-defining district of the City of Conway. The district gives Conway its "river city" distinction and the historic context of this district within proximity to downtown make it a true destination. Conway does not have any multi-story mills in the district, as it was more a center of distribution, rather than production.

Some of the oldest buildings are in, or immediately adjacent to, the WRD on the City-side of the River (official City zoning districts continue on the south and east banks of the Waccamaw River, and east of the river branch that runs north/south along the east side of the downtown commercial district). The actual "Waccamaw Riverfront Historic Design Review District" translates only in the area along the west bank of the river (under the bridge), west to properties on each side of Elm St. and north to 2nd Ave/ Kingston St. (see Historic Districts Map, Fig. 1.1, Pg. A.5).

The railroad played a major role in developing the Waccamaw Riverfront area from a river-port to a major distribution center. Much of Conway's history and wealth is based on this link from the river, inland. The rails also historically, aesthetically and architecturally divide the WRD HDRD into two sub- "character areas," each with their own appearances (See Fig. 5.1):

- A. "River-Side of the Railroad"
- B. "Town-Side of the Railroad"

for new mixed-use development, provide for the public's use and enjoyment, and to provide for the protection of the river bank. **The area demands very specific building placement and setback requirements found in the Conway Unified Development Ordinance (UDO Section 6.4). These are taken into consideration by the Community Appearance Board with these guidelines pertaining to restoration and new construction.** While the Conway UDO controls land use and the vistas of the riverfront, these guidelines help preserve the aesthetic qualities, maintenance, psychological and social connections (thereby every property owner's investment in this area) to the character of the Waccamaw Riverfront HDRD.

Fig. 5.1: Conway WRD Character Sub-Areas Map

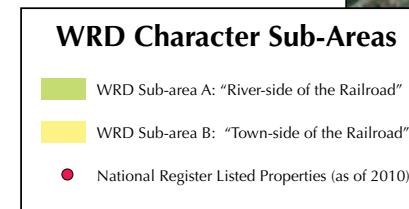

Conway WRD sub-areas, base image: Google Earth 2010

The Waccamaw Riverfront District is an incredibly unique area in that it combines historic building forms with green spaces. Mature trees and native plants, thriving coastal-river flora and fauna, and eco-tourism as well as public festivals can be programmed into the Riverwalk through a system of public parks, boardwalks and docks. The district houses a full-functioning marina, hotel and state of the art tennis center, also. Guidance with design elements in this single, yet diverse, HDRD become very important where buffer areas and the balance of the built and natural environment are a primary concern.

9.1. Character Sub-Areas of Conway's Riverfront

When we look at the two character sub-areas of the Waccamaw Riverfront Historic Design Review District (HDRD) (see Fig. 9.1) two major periods of development are evident in the historic development of the district. The area initially developed with the building of wooden structures close to the River. The earliest warehouse buildings in this area, during the late 1870s - 1890s were often expanded or added on to with the

demand of storing and transferring goods in a growing region. Wooden warehouses for items such as tobacco or lumber, however, remain drier and ventilated. After the location of the railroad lines and in the early 1900s, better fireproof masonry construction technology and steel beam spans were constructed as time and money allowed.

A) RIVER-SIDE OF THE RAILROAD (characteristics in general):

The architectural design of structure on the river side of the railroad tracks should utilize features from the lumber and tobacco warehouses and the naval store. Elements associated with these historic examples are:

- Clapboard siding
- Equal and un-equal gable roofs
- Roof monitors
- Clerestory windows for light, multi-pane wood sash windows
- Wood pilings and brick piers
- Random or irregular siting oriented toward river banks.

These architectural elements are all very significant to the context of a rural historic appearance. When combined with complementary landscape plantings, these features will unite the WRD into an attractive, inviting and "educational" environment tied into the historic beginnings of Conway.

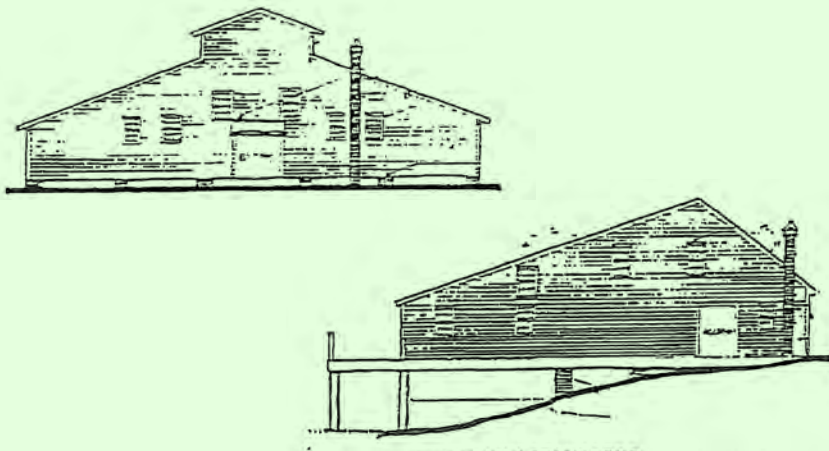
**B) TOWN-SIDE OF THE RAILROAD (characteristics in general):**

Structures on the town side of the railroad tracks consist of:

- Solid brick, block or poured concrete foundations and walls
- Flat or vaulted roofs over steel spans
- Roof monitors for ventilation (or areas for new solar panels)
- The availability of electrified lighting and HVAC (fewer windows)
- Raised loading doors along railroad side to access boxcar height
- Warehouse "blocks" conforming to downtown street grid

A "hybrid" form of contemporary architecture is emerging near the marina that is a combination of the vernacular wooden buildings. Here, materials and features of those nearest the river with a pedestrian-scale "townhouse" form, more characteristic of the Central Business District (clapboard, Georgian Revival Homes and shop forms of the mid-1800s), is found. This "transitional" construction (sketched below) lends itself to the gridded, structured lots town-side of the railroad, it can be arranged within the open, natural lots on the river-side of the railroad and fits in context near the National Register warehouses. This creates potential for new blocks of buildings that will invite visitors toward the Riverwalk, encourage building owners to rehabilitate the large existing buildings and give developers a pattern for pedestrian-scale infill and recreation-based commercial buildings.



9.2. Common Warehouse & Storage Bldg. Forms

Gable-end Shed & Pole Storage Barns

Generally, this is a one-story, single or multiple bay building. This stand-alone "pole barn" is essentially a gable-ended building form. It remains the simplest, vernacular form for storage built today. Materials and shed additions vary. Later, full roof shed additions could be made from the ridge outward to expand floor space, creating off-set or irregular gable ends.

Heavy Timber Post & Beam

The designers and builders of specialized storage structures utilized the technology available for the period. Warehouse construction of the late 1800s was not much different than heavy grist mill or barn construction. This construction method consisted of heavy timber posts, king (and queen) post & beam timber trusses, and floors with thick planks. At first, heavy timber was better than wrought iron, steel, or cast iron. The solid masses could not burn freely or melt, and allowed time for fighting fire. Construction avoided concealed spaces between floors and in roofs. Vertical openings were brick-lined and doors were wood, often covered with tin. Timber construction presented convenient surfaces for attachment of pulleys, shafting and machinery. Ventilation and light come from clerestory windows running along roof monitors.

"Fireproof," Masonry, or "Mill Construction"

Brick and steel provide the greatest floor area, yet brick walls can not stand up for any great length of time against a hot fire. Reinforced concrete was the earliest construction found not to give way in the hottest fire. Even structural steel must be protected by brick or terra cotta, concrete or applied coatings. The worst damage to concrete would be the spalling of some of the surface mortar that could be easily repaired by plastering the damaged places with a rich cement mortar. Typically walls would be six inches thick with the floor slabs being four inches thick. This construction is preferred closer-in to the dense central business blocks and neighborhoods. Water piping can be run throughout the building and gravity tanks for storing water to supply sprinkler systems were positioned on flat, reinforced roofs. 20th century windows are heavy galvanized iron and double glazed with quarter-inch wire glass. With electrified ventilation and lighting buildings can be completely self-contained, and could accommodate cold-storage and large, open spaces.

Fig. 5.2: Most Predominant Warehouse Form Examples



All Images Conway, SC 2009

(Above, left) Storage sheds found in the area of the River (south of the HDRD) are good examples of a gable-end shed. Note the connected porch and roof pitch of the side shed addition. (Above, right) Larger wooden warehouses are built with main mass along the river banks and storage extended out over docks and wood piers. (Below) Later, larger warehouses were needed as distribution demand grew.

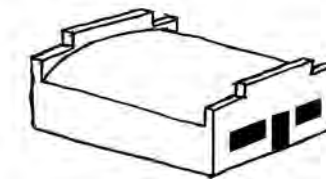
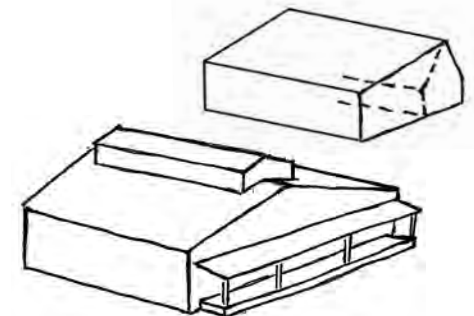

All Images Conway, SC 2009

Storefronts became a prominent feature closer to the downtown central business district. Stepped-parapet upper facades conceal gable and vaulted roofs. (Right, top) Brick "fireproof" warehouses along 2nd Ave. roof viewed from the side. (Right, bottom) Similar historic warehouse & industrial structures can be found in the southern blocks of the Commercial HDRD.



9.3. Waccamaw Riverfront Development Standards

Preservation of Viewsheds

The Waccamaw Riverfront District must remain a balance of traditional historic architecture and nature in order to produce and preserve it as a destination as well as an recreational amenity. Standards have been established to provide appropriate accessibility to structures as well as to insure a complementary appearance and relationship to one another (request information from the Conway Planning Department for the *Conway Unified Development Ordinance (UDO)* to find property line setback and height requirements in the WRD. **A riverfront setback of 25 feet is part of the Conway UDO to allow adequate room for a continuous boardwalk while preserving vegetation along the River's edge.**

Public Amenities & the Boardwalk/Riverwalk

Elements that also impact the appearance and functionality of the riverfront area are the boardwalk and riverwalk amenities (such as benches, trash receptacles, construction of the railings and lighting) provided by the City of Conway. Lighting of the site, especially, should complement the natural "feel" of the district. If amenities are provided by individual properties or connected to structures they should go through additional CAB and Planning Department Review. Low-mounted wash lighting and limited overhead-mounted spot lighting for signage is recommended. Many areas can still support new construction directly along the path system.



Conway Riverwalk, 2010

Coordinated benches, swings, arbors, trash cans, pavilions and informational signs are all part of the Conway Riverwalk system that blends specifically chosen materials into the landscape.



Conway, Riverwalk, 2009

The Riverwalk expands the usability of previously inaccessible areas. Lighting fixtures for the paths and paving on ground surfaces is coordinated by City Planning. Safety and comfort are key, however so is the impact on the habitat.

Fig. 5.3: Understanding Important Setting & Views

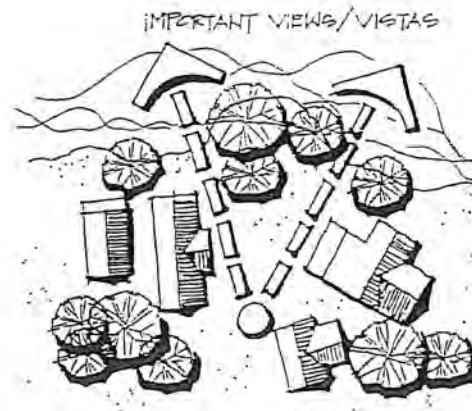

Conway WRD, 2009

(Above & Below) Images of low, sparse-density development blended with nature and openings for vistas.



Conway WRD, 2009

Fig. 5.4: Features of the Boardwalk/Riverwalk Amenities



Conway Boardwalk, 2010

The Boardwalk sections of the Riverwalk are peaceful and allow the visitor to experience the Waccamaw River just a few hundred yards from the activity of downtown.



Conway, Arboretum on riverwalk 2009

The Riverwalk, itself, is a tourism tool. Horry County will incorporate resources and activities into county-wide marketing and programming. Signs are low, ground lit and accented with a plant palette.

9.3. Waccamaw Riverfront Environment (continued)

Infill, Parking & Multiple Structures Per Lot

Infill opportunities on vacant lots are available in many areas throughout the WRD. With minimum lot sizes set at 5,000 square feet (*UDO* Article 6.4.1), controlling building placement within the “yard” and height in the Waccamaw Riverfront HDRD is not meant to prevent or limit new development within the district, as much as it is to encourage an open, natural environment. Many WRD lots are not located directly on the river or on existing streets. New streets and parking areas may need to access interior lots. Per *UDO*, multiple structures can be built on single lots, but will require different setbacks (meet with City Planner for details, also see Fig. 5.5 at right).



All Images Conway, SC 2009-10

(Above, left) The 21st century residential construction near the Kingston Marina is a good example of balancing parking, building setbacks, landscaping with appropriate height and scale requirements. (Above, right) Smaller buildings placed into the WRD visually benefit from landscaped setbacks and will be cooler when trees grow in.

Setback from Curb Along Streets & Sidewalks

The setback from curb with multiple planting areas will differentiate from the denser, “zero-lot line” development near the Central Business District (townside of the railroad in the HDRD) to the interior and riverfront lots (*UDO* Article 6). This ensures that adequate space will be available for pedestrian circulation as well as for additional landscape amenities that contribute to the natural environment of the WRD.



Conway, SC 2010

(Left) Note additional planting zone along the building front. In contrast to the dense Central Business District, just one block north, this converted industrial structure begins the transition to the more open, natural environment of the riverfront.

Fig. 5.5: WRD Interior & Multiple Structures per Lot Regulations

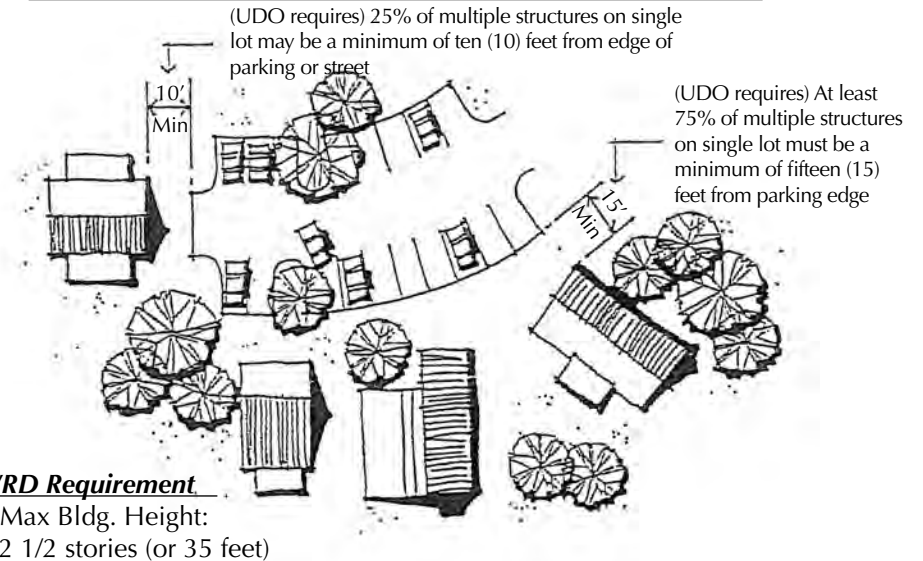
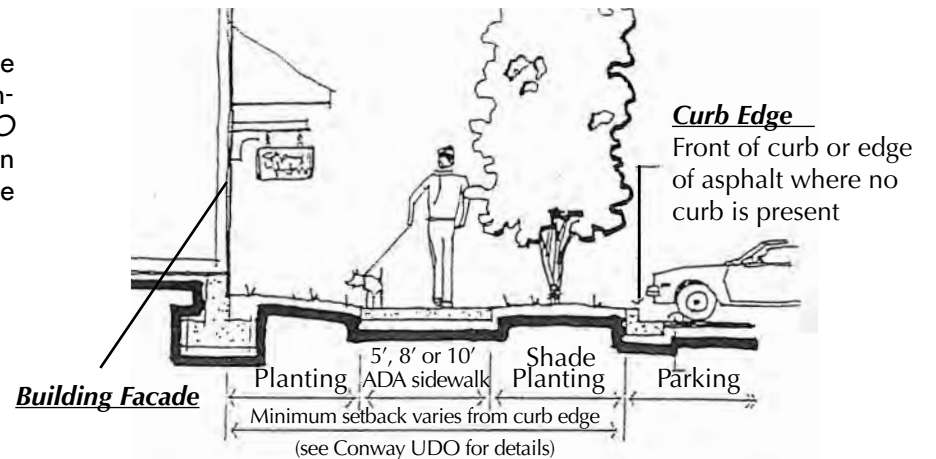

Fig. 5.6: WRD Sidewalk Planting Zones & Curb-to-Bldg. Setback



Riverfront Buffer Areas: Recreation & Nature

From the *Waccamaw Riverfront Area Plan* a Riverwalk system of boardwalks and paths was created as recreational and pedestrian control for visitors to enjoy the area. Its design and location also preserves the delicate ecosystem of the river banks and ecology underneath. At the right (Fig. 5.7) a master boardwalk system plan view was created to identify boardwalk placement and its relationship to existing vegetation and potential structures. (A, B & C) Three cross-section examples show use of a 25-foot buffer area that satisfies development regulations.

CROSS SECTION A - EXAMPLE:

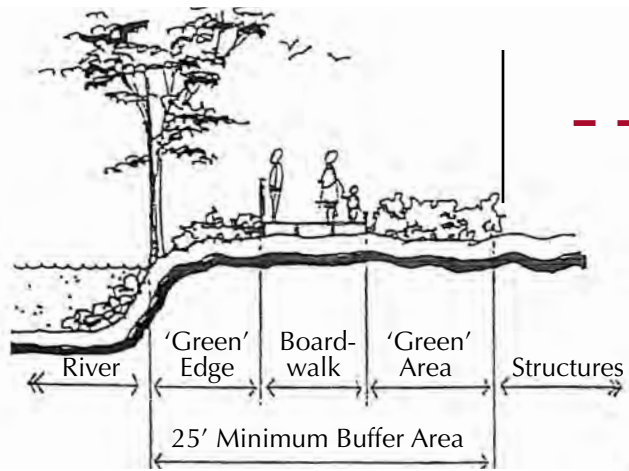

CROSS SECTION B - EXAMPLE:

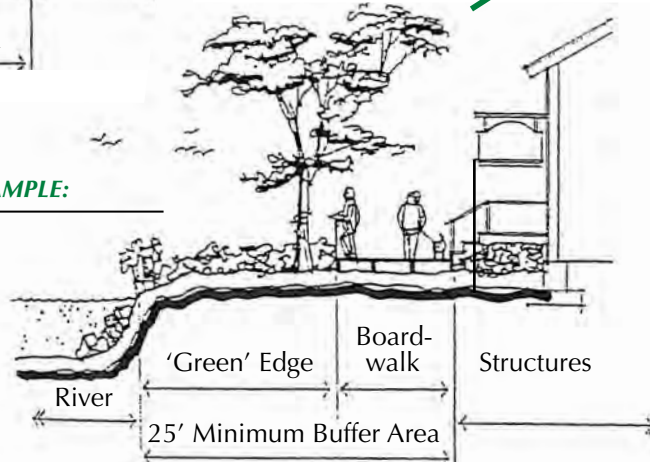

CROSS SECTION C - EXAMPLE:

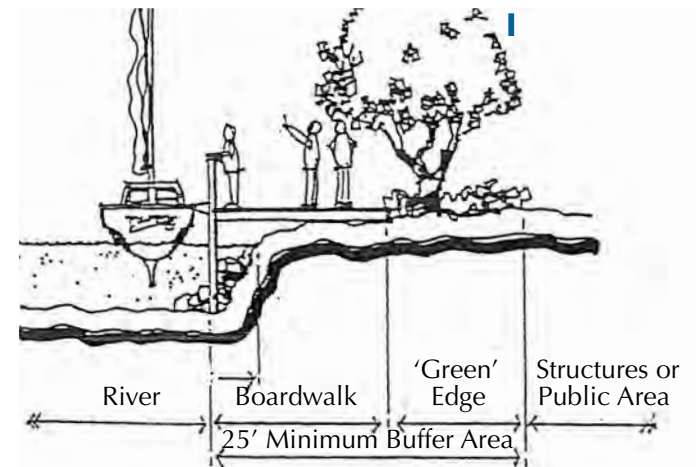
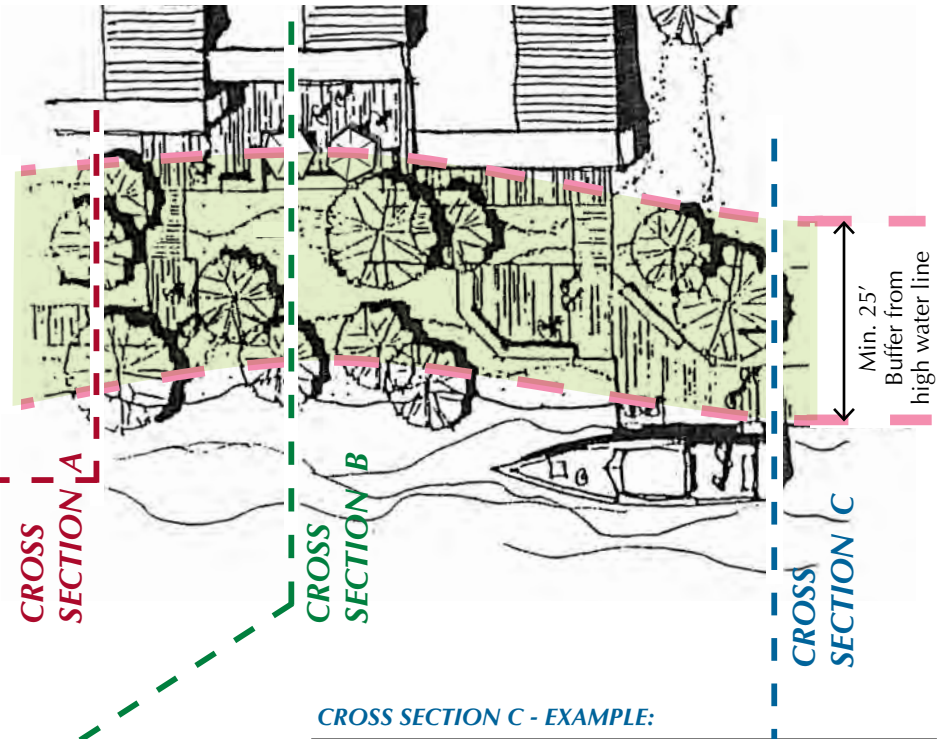

Fig. 5.7: Boardwalk System Plan & Cross-sections



10.1. Riverfront Building Preservation

General Standards & Features



Conway, SC 2009

Many of Conway's historic Waccamaw Riverfront warehouse buildings are wood. Their utilitarian form and changes in functionality are part of their industrial character.



Conway, SC 2009

Historic structures in the WRD are challenging. Their shear size and historic materials such as wood, tin and iron demand more maintenance and skill to preserve their value.



Conway, SC 2009

The Cypress Inn at the marina is a landmark structure. It inspires the character of new infill, materials and urban forms of architecture in the WRD, on both sides of the railroad.



Conway, SC 2009

Vernacular industrial building facades are covered in mid-20th century materials. These may tell a story about a business, however the small wood porch and tiny window are out of style and scale in context to area.

Appropriate

- 10.1.1 Preserve (retain, restore and maintain) first and foremost, any original features and site-specific building construction, and second, those changes that have gained historic significance over time. (See "Secretary of the Interiors' Standards" on Pg. A.11)
- 10.1.2 Retain (and repair) rather than replace deteriorated original features.
- 10.1.3 If replacement of parts is necessary due to severe deterioration, replace with features to match (accurately duplicate profiles, massing, scale) in design and materials (Figure 5.8).
- 10.1.4 If the original or intended design of architectural features cannot be determined using photographs or historic resources, use like-materials with features, proportions, profiles, massing and traditional arrangement typical of similar structures of the same form and style.
- 10.1.5 Assess significant additions or expansions of later periods that use quality materials or industrial technology, which may have completely replaced original features. If such remodeling is architecturally important, has significant industrial or commercial history, or is noteworthy, preserve these features as noted above.
- 10.1.6 Always use the gentlest cleaning methods possible which include simple washing with mild detergent and natural bristle brushes, or specific restoration chemicals if stronger cleaning or paint removal is intended.

Inappropriate

- 10.1.7 Never sandblast or use any abrasive cleaning methods on historic materials. **The materials are older and softer and will be permanently and irreversibly damaged.** This includes high-pressure water washing unless monitored by a professional historic preservation sensitive contractor using appropriate restoration cleaning chemicals.
- 10.1.8 Do not immediately remove original or historic material if it does not seem to comply with modern building codes. There is a dollar value to saving irreplaceable historic elements if additional alternative code solutions can be made. **Historic material is MOST valuable when retained in place.** Check with City Building Official or City Planner and ensure that all state recognized measures for historic preservation are taken to save historic material. (See Appendix IV: "Resources" for assistance).
- 10.1.9 Do not repair or re-point masonry with harder- (Portland cement) based mortar or contemporary engineered bricks if the existing masonry is not the same. Contemporary materials are too hard and rigid for softer (lime-based mortar & handmade brick) composition masonry, and will cause permanent irreversible damage to the original.
- 10.1.10 Do not install brick veneer or siding over or in place of original wood siding and do not use synthetic or "wood appearing" siding on the historic structures on the "river side" of the railroad tracks.

10.2. Riverfront Warehouse Openings

Entrances, Doors & Loading Doors



Conway, SC 2010

Original “board and batten” doors (that access to the Boardwalk or historic dock area) on the National Register riverfront warehouses are incredibly character defining.



Conway, SC 2009

This older “fireproof” tin sheeted sliding loading door (at one time level with the floor of boxcars) is an incredibly character-defining feature of the HDRD and should be maintained and saved.



Conway, SC 2009

Aside from warehouses, new recreational, institutional and residential entry features within the WRD have raised panel construction and less glass, in a Neo-Colonial style.



Conway, SC 2009

Larger industrial openings can be simply and aesthetically infilled with contemporary entries and “storefronts.” Note the continued use of heavy profiled wood framing.

Fig. 5.9: Features of Doors and Openings in the Riverfront Area

10.2.1 **Preserve (retain and restore rather than replace), or replicate if necessary, any entry system, if a part of the original warehouse/riverfront architecture (angles, depth, recessed, flush or other).**

(If an original storefront is part of the architecture then all general storefront features and guidelines for CAB review are outlined in the previous Section B, Commercial Guidelines, (all of) Chapter 4.1 “Storefronts.”)

Appropriate

10.2.2 Preserve (retain, restore and maintain) any original entry (especially loading doors) and the scale/construction of their openings.

10.2.3 Retain (and repair) rather than replace deteriorated door parts.

10.2.4 If replacement of parts is necessary due to severe deterioration, replace with features to match (accurately duplicate profiles, massing, scale) in design and materials.

10.2.5 If original doors cannot be determined using photographs or historic resources, custom wood replacement doors are preferred that fit the, often oversize and custom warehouse openings.

10.2.6 Door hardware, if missing on originals or on replacement doors, should be of the same type of like hardware on similar buildings in district.

10.2.7 Retain later-period doors from significant modern adaptations of the industrial properties with important commercial history to the use of the building or those using quality modern materials.

Fig. 5.10: Illustrated Examples of Preserving Loading Doors & Openings

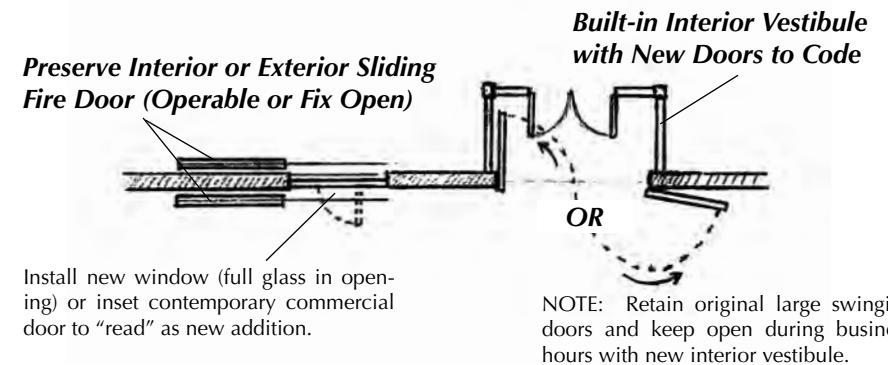

Inappropriate

10.2.8 Residential doors (form and style) are not permitted on industrial entries, as well as “French doors” (those containing multiple divided glass panes).

10.2.9 Do not immediately remove original loading doors if they do not comply with modern building codes. Check with local code official or City Planner and ensure that all state recognized measures (potential “code alternatives”) are taken to save historic material. (See Appendix D: “Resources” for assistance).

10.2. Riverfront Building Openings (continued)

Windows & Fenestration



Both Images Conway, 2009

Wood sash windows set into openings at different levels and board-&-battened shutters (functional and fitted to meet when closed) are a character feature of warehouses, river-side of the railroad.



Conway, 2009

Windows, town-side of the railroad, are more residential, evenly spaced, with profiled mullions and openings traditionally set into walls. These may or may not have shutter associated with them.



Both Images Conway, 2009

(Left) Contemporary transom windows fit above a new entrance, help preserve the original opening. (Right) Brick-front bulkheads below a warehouse display window.



JB-ra Photo archives, 2008

Faux shutters placed on contemporary architecture (where there is no need for windows to the interior) continue the rhythm of window openings in a character-sensitive manner to the district.

Appropriate

- 10.2.10 Preserve (retain, restore and maintain) original windows.
- 10.2.11 Wood is the most traditional window material, however dependent upon the age and style of the building (and location of the windows) steel, aluminum, glass block and other materials may have been used from different eras. Research materials from the era of your building.
- 10.2.12 Retain (and repair) rather than replace deteriorated window parts.
- 10.2.13 Assess the mechanics of each window and repair as needed. If replacement of parts is necessary due to severe deterioration, repair with pieces to match (accurately duplicate profiles, massing, scale) in design and materials. (See item 10.2.17 for weather seal.)
- 10.2.14 If original windows cannot be determined using photographic or physical evidence, then provide custom replacements that are compatible with the architecture of the building. Replacement windows should have glazing proportionate to the opening with mullions (generally deeper profiles) that divide windows in panes per sash. Surfaces should be paintable.
- 10.2.15 Preserve (retain, restore and maintain) original casings and bulkhead material, especially maintaining the integrity of mitered trim work, profiled framing, or wood craftsmanship (and even the industrial "patina" of where carts or wear has occurred below lower floor windows that portrays industrial character to the history of the area).

- 10.2.16 If sash weights and weight pockets still exist, these historic features should be retained, rebalanced or repaired. If these pockets are no longer used, insulate with fiberglass batting, which is reversible (do not fill with expanding-foam). Some historic windows have been retrofitted with aluminum compression channels rather than sash weights or have had these installed over the years; assess their integrity to potentially restore the weights. Use chain, wire, nylon, or natural rope that will not degrade in UV light to replace cords.
- 10.2.17 For appropriate weather seal (wood or metal windows) use weather stripping or route flexible weather stripping into wood sash styles. Caulk open case-ment joints and spaces around aprons. Use interior storm windows for ease of maintenance from upper floors and historic profile appearance from street.

Inappropriate

- 10.2.18 Avoid replacing historic windows with off-the-shelf replacements or new windows that do not equally fit the original framed opening.
- 10.2.19 Avoid vinyl, plastic or fiberglass parts as these are not of a historic nature and degrade quicker in UV light compared to wood. They often do not share the same profile dimensions of the historic material.
- 10.2.20 Grid-between-glass or "snap-in" flat vinyl mullions are not allowed.

10.3. WRD Foundations, Piers and Crawlspace



Conway, SC 2009

The boardwalk and its connection to many of the structures along the banks of the Waccamaw is on an elaborate system of piers.



Conway, SC 2009 (Top: close-up of bottom)

Raised brick piers leveled the floors on uneven ground and allow air movement needed under the oldest wooden structures of this size.



Conway, SC 2010

Solid brick foundations carry wooden structures in sections of the district along streets. The ground here is more stable and level. However ensure foundations remain vented.



Conway, SC 2009

New poured masonry piers and lattice-work venting are used to construct and cover the raised foundation of the (ca.2005) Historical Society building (found on the town-side of the railroad).

Appropriate

- 10.3.1 Preserve (maintain or restore, not enclose or alter) original porch, boardwalk and foundation framing and their design, whether they are exposed wood pier, brick or stone, etc. Do periodic maintenance checks on timber sills, cladding and floor joists and keep treated for termites.
- 10.3.2 Retain any original loading docks, loading platforms, trapdoors, hoists, etc. even if the property is no longer used for storage or industry or if the transportation element (trains, trucks, carts, boats, etc.) is gone. This will preserve the history of the building's function and how it served as a piece of the distribution network in the WRD.
- 10.3.3 Ensure grading and landscaping shed water away from the foundation. If water infiltration is an issue along the building install a "French drain" system along the foundation and carry water away (down to the river bank or to a curb serviced by a storm drain).
- 10.3.4 In solid masonry foundations with crawlspaces ensure proper venting of the crawlspace is occurring (open vents during summer and close during winter to protect pipes from freeze).
- 10.3.5 **(See Section D, Chapter 8.4 "Masonry Walls" for review criteria and information on material treatment and maintenance.)**
(See also Section E, Chapter 10.4 (next page) "WRD Exterior Walls")

Inappropriate

- 10.3.6 Spray-on polystyrene, "blown-on" coatings, built-up mesh, or exterior insulation finishing systems (EIFS) materials are not be used to replace, rebuild, cover, conceal or infill the open area between historic masonry foundation piers. Enclosing crawlspaces with solid foundation material (especially synthetic materials) can cause serious moisture build-up in wood and masonry material in the river environment. (Do not underpin with solid masonry units where none existed, either.)
- 10.3.7 Do not remove or add your own course-work (banding, trim, cornices, etc.) that was not intended for the period of architecture, by the original building design. Use historic photographs to prove details before they are falsely subjected.
- 10.3.8 Do not dig out foundations under buildings to gain extra levels or install basements. The environment, so close to the river could flood or hit high water tables that will destroy historic masonry foundations. Also, older brick or wood piers, buried for decades or more, exposed to air will deteriorate and would not carry the weight of the massive building piers.

10.4. WRD Buildings' Exterior Cladding

Siding & Clapboard (Historic VS. New)



conway, SC 2009



conway, SC 2010

Natural surfaces (without latex paint or contemporary coatings) may not be as protected, however material dries quicker. Worn paint is seen on some surfaces. Additions are easily seen.

The reveal on this plank siding (10 to 12 inches) is testament to the irreplaceable dimension of old growth lumber. Repair patches add patina to the industrial area.



conway, SC 2009

(ca.2000) Townhomes near the marina use contemporary siding materials and trim, yet siding has thick profile, wide reveals and painted muted hue.



conway, SC 2010

New clapboards (whitewashed scheme) on additions to the Cypress Inn reflect a "refined" location where people, rather than supplies, are housed. (Cement fiberboard & wood siding shown)

VS.

HISTORIC (NATIONAL REGISTER) WAREHOUSE SIDING MATERIALS:

The nature and appearance of the historic warehouse exterior is a challenge for the rehabilitation into modern interiors. The sheer size and industrial nature of the warehousing buildings play a major social factor in the appearance of the buildings that we consider the "historic" landmarks in the WRD. Most appear as if they were not painted (or had inexpensive "whitewash" applied at one time, now worn off), probably due to cost. The cost of insulating, or making these buildings air-tight was not of importance and it would have been more efficient to replace material then maintain paint. Air passage was needed so cracks were OK. Features include:

- Wood clapboard siding (generally large reveals of 8 to 14 in.)
- Very little overlap (for efficiency of replacing material and air)
- Unfinished surfaces (or once "whitewashed" with natural coatings)
- Structures have both equal and irregular reveal and board length
- Knotty wood and quarter-sawn materials
- Additions were not blended & siding materials simply change at vertical divisions (often material stripped was used in new section.)
- Exterior clapboard walls without insulation & installation (with required historic "reversibility") will take creativity
- Lack of corner boards

10.4.1 (Apply the above aesthetic criteria and see Section D, all of Chapter 8.4 "Exterior Walls and Insulation" for review criteria and information on material treatment and general maintenance applied to WRD siding, clapboard and masonry walls.)

NEW CONSTRUCTION (& RE-FINISHED) WRD SIDING MATERIALS:

Keeping the context of the "weathered" natural siding and scale of the industrial materials and working with the National Register buildings, often in proximity or within sight distance to new construction, nearby is a unique challenge to maintaining the sense of place of the WRD. Finish details for structures that will be inhabited in must be to code, yet have the aesthetic appearance of the WRD character sub-area (or Secretary of the Interior's Standards-quality addition to National Register property) where the new construction is located (see Chapter 9.1 & item #10.4.2 below). New construction & features should include:

- Wood (or generally cement fiberboard) clapboard siding should have large reveals (8 to 10 in.) and over-size thickness.
- Higher floor heights (for scale) require greater expanse of siding.
- "Whitewashed" surfaces, natural or "buff" hues are suggested
- Identify new construction from old: avoid "simulated" wood grain materials, reveal and board length should match - **do not falsify new construction by using rustic or reclaimed, weathered boards**
- Corner boards, sill fascias, trimwork on finished work (painted white, or contrasting brightness is optional)

10.4.2 Generally, for historic context, wood (or clapboard-appearing new construction) should be followed on the river-side of the railroad, while wood, or, more-so brick or CMU "fire-proof" construction, are both appropriate on the town-side of the railroad in the WRD HDRD.

10.5. WRD Roofs, Canopies and Roof Lines

Columns, Brackets, & Eaves (incl. Sheds)

Fig. 5.13: Illustrated Traditional Industrial Canopy & Bracket Types

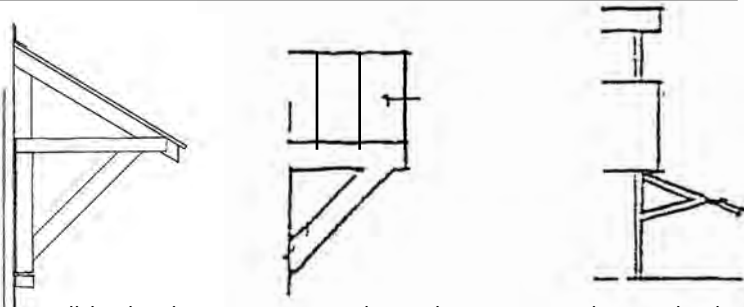

Not all bracketed canopy types are shown above (nor in scale to each other). (Left to right) Side profiles of open-end wood bracket shed canopy & vertical attached wood posts, simple gabled wood bracket porch cover with standing seam roof and large projecting metal braced truck/cart loading dock cover (10 - 16 foot projection).

Appropriate

- 10.5.1 Preserve (retain, restore and maintain) any original industrial railing, eave, bracket or column material.
- 10.5.2 Preserve (maintain or restore, do not remove, cover, or alter) the eaves and simple nature of exposed brackets, rafter tails, flashing and trim.
- 10.5.3 Retain (and repair) rather than replace deteriorated rigid canopy parts.
- 10.5.4 If replacement of parts is necessary due to severe deterioration, replace with features to match (accurately duplicate profiles, massing, scale) in design, construction, projection and materials.
- 10.5.5 If original canopies cannot be determined using photographic or physical evidence, then provide a design that is compatible with the architecture of the building and/or in keeping with similar structures in the adjacent WRD area ("river-side" or "town-side" for character, See Pg. E.2 "Character Areas of Conway's Riverfront"). Generally, replacement trim, decking, brackets (columns if existing) and railings should be proportionate to the original construction. **Non-decorative wood framing is preferred for structures on the "river-side" of the railroad** with use of an industrial palette of materials (such as steel, tin, sheet metal, etc.)
- 10.5.6 Retain later-period porches that match modern changes, additions or upgrades with significant architectural history.
- 10.5.7 If no porch railings exist and are needed for safety, install lightweight wood or wrought iron units painted neutral hue to visually recede.

Fig. 5.14: Features of Porches and Canopies in the Riverfront Area



(Left) Use of different types of rolled, corrugated, "v" or "w" lapped or standing seam metal panels are appropriate for the WRD industrial character of canopies and porch coverings. Utilitarian, contemporary buildings such as the marina public restrooms also use this material. Avoid use on residential structures. Note simple eave detail.



(Above, left "town-side") Square columned porches and deep eaves are a Cypress Inn feature.

(Above, right "river-side") Simple, bracketed canopies on contemporary construction of the Marina clubhouse.

(Right) Long porches with lightweight steel bracing allowed goods to be moved from warehouses to rail and trucks under shaded and dry conditions, free of columns.



Inappropriate

- 10.5.8 Do not remove, replace, reduce, cover, or alter original porch material.
- 10.5.9 Do not sandblast or use any abrasive method to clean or strip, including high-pressure water. Use only gentle, restoration-sensitive chemical cleaners and strippers or mild detergents and natural bristle brushes on wood or brick.
- 10.5.10 Do not enclose industrial porches or loading docks or install permanent glass enclosures in replacement of or in front of existing porch elements. This would not have been part of the industrial riverfront environment. Accurate historic character creates a tourism destination district. Full screens, retractable blinds or plastic curtains may be used for porch dining options if mounted to inside of columns or set back from porch edge under canopy overhang.

10.5. WRD Roofs & Roof Lines (continued)

10.5.11 See Section B, Chapt. 4.2, "Commercial Roofs," and Section D, Chapt. 8.5, "Roofs and Rooflines," Item #s 8.5.1-6 for review criteria and information on treatment and general maintenance also applied to WRD roofing.

10.5.12 See Section D, Chapter 8.5, "Chimneys, Eaves & Parapets," Item #s 8.5.10-14 for review criteria and information on material treatment and general maintenance also applied to WRD features.

Fig. 5.15: Features of Warehouse & Industrial Roofs in the Riverfront Area



Roofs and rooftop monitors are defining features of historic warehouses. Large expanses of pitched surface is appropriate for metal roofs.



Old and new seam metal roofing. Originally overlapped "V" or "W" joints were used, modern versions are rolled & crimped.



Roofing and eave details of the contemporary-compatible construction on the marina clubhouse (implied roof monitor optional).



The "fireproof" masonry and barrel vaulted roofs of the warehouses along 2nd Ave, lower, denser "town-side of railroad" forms.

Industrial Roofing & Covering

Appropriate

10.5.13 Maintain the longevity of the original material if it is of a quality such as slate or metal where individual sections can be repaired. Generally this will be standing seam for the warehouse buildings and applied or rolled roofing on the flat or barrel roof structures. Finish residential forms and building types as residential roofs stated in Item # 10.5.11 above.

10.5.14 If replacement is necessary and roof covering is proven to not be made any longer, substitute an approved "architectural" compatible roofing material upon the age and style of the building. Composite shingles may only be required on a few of the residential and public buildings in the sub-areas of the WRD closer to the Central Business District.

Inappropriate

10.5.15 Do not use roofing material of different color or composition from what has a visual appearance of what would have originally covered the building type.

10.5.16 Generally avoid composite "tabbed" residential shingle roofing, inappropriate for the WRD industrial area unless the building is of a residential nature.

Roof Pitch & Curved Roofs

10.5.17 Retain intended roof pitch. The most character-defining element of large buildings.

10.5.18 See Section B, Chapter 4.2, "Commercial Roofs," Item #s 4.2.21-30 for review criteria and information on understanding roof forms.

Roof Monitors, Vents, Skylights & Chimneys

10.5.19 Preserve (maintain or restore, do not remove) original form of roof monitors, vents & skylights. The shape of these historic features define the building forms of the WRD HDRD warehouses. They bring in natural light to reduce electricity and can be retrofitted to vent large interior spaces.

10.5.20 Repair or replace missing clerestory windows based on accurate duplication of openings and close visual approximations of the original. Historic photographs are a primary reference source. Temperatures in monitors get extremely high, avoid PVC, vinyl or plastic that can warp.

10.5.21 Chimneys may denote office location in the warehouse and are a valuable historic feature. Preserve, retain and repair existing chimneys.

10.6. WRD Public Amenities and Features

Landings, Patios & Connections (to Boardwalk)

The unique creation for the Waccamaw Riverfront District, through the *Riverfront Area Plan*, was the creation of the boardwalk system. Many of the riverfront warehouses and structures have been creatively tied into this system so that visitors can enjoy using and viewing the structures from all sides. The Riverwalk (paths and gardens), which ties into the boardwalks, provides a continuous visitor's experience.

- 10.6.1 Public boardwalk / riverwalk should always be river-side of any public development or private patios. Private use of boardwalk for tables, displays or goods should be discussed with City Planning for permits.
- 10.6.2 If porch, entry walk, primary entry door, outdoor patio area or loading dock can be connected to the Riverwalk system check with City Planning Department for appropriate materials, connections and railing along the public walkway edge MUST conform to all public design standards..
- 10.6.3 If property adjoins directly along the Riverwalk/boardwalk and a railing is desired where none exists or an opening/gate is desired through an existing public railing, apply with City Planning Department.
- 10.6.4 A dining or public patio with a direct connection to the Riverwalk/boardwalk system is encouraged to have the primary entrance through the building and/or an operable (closed after hours) gate through a railing or physical separation (vegetation) along the public walkway.

Railings & Private Fences Along Riverwalk

- 10.6.5 No property owner may construct another railing or fence of any kind closer than six (6) feet back from an existing public railing or edge of walkway, measured at 90-degree angle back from the public resource.
- 10.6.6 If a physical connection with public railing is desired, at any angle, owner must use the public railing design for six (6) feet back before transitioning to another railing, measured at a 90-degree angle from public railing.
- 10.6.7 No property owner may construct another railing, fence or line of vegetation that is higher than the public Riverwalk/boardwalk railing system or that will block the view of the River from a public street or right-of-way.
(See also Chapter 9.3 "Riverfront Buffer Areas" to ensure designs meet the protection of green and planted areas).

Fig. 5.16: Cross Section Plans of Patios and Connections to Riverwalk

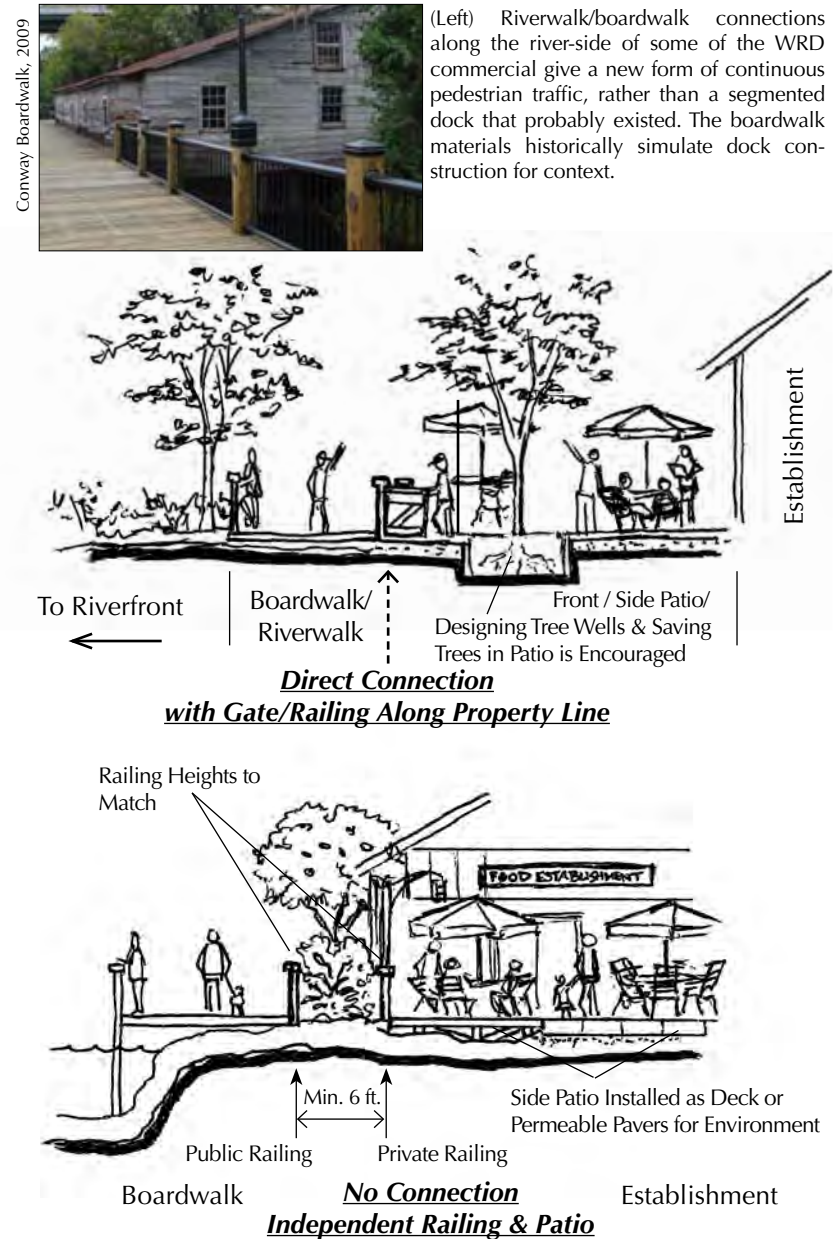

(Left) Riverwalk/boardwalk connections along the river-side of some of the WRD commercial give a new form of continuous pedestrian traffic, rather than a segmented dock that probably existed. The boardwalk materials historically simulate dock construction for context.

10.6. WRD Public Amenities (continued)

WRD Sign Standards & Area Lighting

- 10.6.8 Throughout the Waccamaw Riverfront HDRD ONLY front-lit signs should be used. Sign materials can be applied dimensional, wood, painted or routed sign-foam (see Section C, Chapter 5.2 “Sign Materials” for more details). This will compliment the historic character
- 10.6.9 Wall mount, blade signs and low, yard monument signs (blade style hung from arm-and-post) can be used. Sign size and scale shall follow Primary, Secondary and Subordinate suggestions found in Section C, Chapter 6 - Primary signs shall not exceed thirty (30) square feet.
- 10.6.10 Limited overhead-mounted spot lighting (bent back toward signs and buildings) or low-mounted (ground) wash lighting for signage is recommended. This is to cut down on glare into river ecosystem.
- 10.6.11 The lighting of the site should compliment the “natural feel” of the District, increase a “romantic” and quiet environment of the riverfront at night. Use primarily incandescent (or simulated) fixtures. Cut down or avoid the use of mercury vapor and silver-halide fixtures which have harsh and bright source lights.
- 10.6.12 Conceal light sources when ever possible in the WRD to avoid spill over into night river habitat. This can be done with light fixtures placed to wash up into trees, “rope lights” set within patio hand rails or shining back onto building faces or signs with an indirect, soft glowing effect (taking care not to shine lights up into pedestrian’s eyes on pathways).

Fig. 5.17: Riverfront Area (River-side of Railroad) Signs & Lighting

WRD Suggested Building Signs

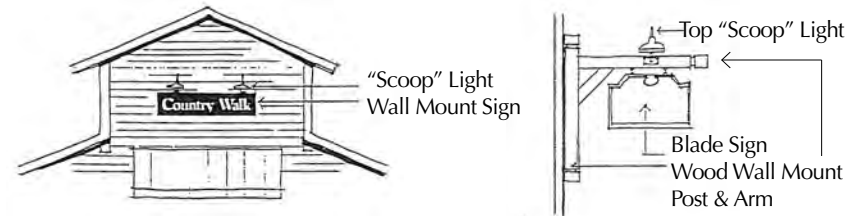

WRD Suggested Monument Sign Lighting & Handrail Design

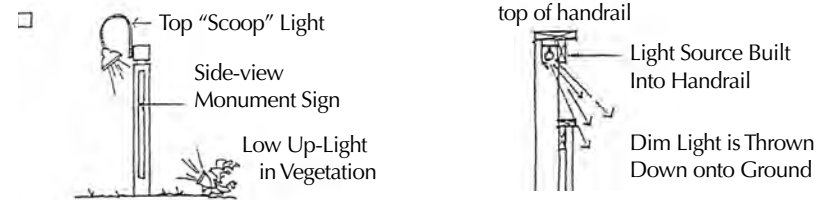

Trash, Dumpsters & WRD Public Furniture

- 10.6.13 “Corral” businesses dumpsters and grease traps with vegetation screening.
- 10.6.14 Hold on the amount of public furniture along public walkways. Check with Conway Planning Department for a preferred list of furniture styles for benches, swings and trash cans. Coordinate more public activity onto private patios and areas.

Fig. 5.18: Riverfront Area Riverwalk/Boardwalk Environment Examples



Light washes in trees and ground washes from concealed sources, without harsh fixtures, can create dramatic night experiences for visitors and respect habitat.



Avoid tables, light poles and furniture set in pedestrian walkways as well as plastic trash cans. Too much seating can create a “vacant” feel along boardwalk.



(Not Conway, example only) Vegetative buffers & screening around grouped dumpster “corrals” constructed of either wood or lattice-work brick walls for ventilation.



(Not Conway, example only) Always keep Riverwalk/boardwalk to the river-side of private development. Keep furniture to a minimum if multiple use area is tight.

SECTION F

DEMOLITION, RELOCATION AND STABILIZATION

Chapter 11:
Process of Caring for Buildings

The demolition of historic buildings diminishes the built environment and creates unnecessary waste. Because demolition is irreversible, all possibilities for saving a threatened historic structure should be explored.

Fires and unexpected catastrophic events can happen and will be inspected. If a building must be removed for legitimate purposes then these guidelines will form a basis for designing a new, compatible structure for the area.

Demolition and relocation is only appropriate in very specific and narrowly defined circumstances. No demolition should occur without approval of post-demolition plans. In addition, the historic preservation article of the *Conway Unified Development Ordinance* incorporates a pro-

active strategy to aggressively pursue remedies for historic properties endangered by the "failure to provide ordinary maintenance."

Each building proposed for demolition or relocation should be evaluated for historic and architectural merit as well as its importance to the character of the site and historic district.

Additional information can be found in the process of applying for a demolition or relocation through the City of Conway's Community Appearance Board (CAB) (see also Appendix II, excerpts of *Conway Unified Development Ordinance*, Article 14.)

11.1. Failure to Provide Ordinary Maintenance

"**Ordinary maintenance and repair**" is any work, the sole purpose and effect of which is to correct deterioration, decay, or damage, and which does not result in a change in the existing appearance and materials of a property (also see COA Approval Matrix pgs. A.12-A.16).

Ordinary maintenance could include, but not be limited to, caulking or re-glazing windows; minor repairs to windows, doors, siding, gutters, etc; replacement of existing mechanical equipment; repairing or repaving of flat concrete work in side and rear yards or repaving of existing front yard

paving, concrete work and walkways (if the materials are the same or similar in appearance); roofing work (if no change in appearance occurs); chimney work (if no change in appearance occurs).

"**Deterioration by neglect**" is the willful lack of maintenance, usually preventable, leading to the demise of a historic building. In the City of Conway, within the local designated HDRD, these issues are addressed through compliance of ordinary maintenance and code enforcement as adopted by the City of Conway, below:

Failure to Provide Ordinary Maintenance (From *City of Conway Unified Development Ordinance*, Article 14.1.3 (K), see Appendix II & forms Appendix III)

Property owners of individual properties within a designated historic district or of designated historic landmarks shall not allow their buildings to deteriorate by failing to provide ordinary maintenance or repair. The CAB shall be charged with the following responsibilities regarding deterioration by neglect:

- 1) Notice to owner to remedy.** *If the Community Appearance Board determines a property owner has failed to provide ordinary maintenance or repair (including but not limited to damaged windows, doors, siding, foundation, or roof structure) the Community Appearance Board shall notify the property owner and set forth the steps which need to be taken to remedy the situation. The property owner shall have 180 days in which to resolve the situation.*
- 2) Failure by owner to remedy.** *If the condition is not remedied within 180 days, the owner shall be subject to the enforcement provisions as specified in UDO Article 15 (Enforcement) or upon authorization and at the direction of the City Council. The City of Conway may perform such maintenance or repair as is necessary to prevent deterioration by neglect. The property owner shall be liable for the cost of such maintenance or repair. The cost of such maintenance or repair shall be a lien against the real property. The lien shall attach to the real property at the time of payment of all costs of maintenance or repair by the City of Conway.*

11.2. Variances for Undue Hardship

When a property owner claims that he or she is incapable of earning an economic return on the value or the use of their historic structure, the burden of proof rests with the property owner.

While property owners have a right to reasonable use of the land, the U.S. Constitution does not guarantee the most profitable use. Federal courts have upheld that if the entire property has a reasonable economic use, a taking of the property has not occurred.

(From City of Conway Unified Development Ordinance, Article 14.1.3 (J), see Appendix II)

Where, by reason of unusual circumstances, the strict application of any provision of this ordinance would result in the exceptional practical difficulty or undue hardship upon any owner of a specific property, the commission shall have the power to vary strict adherence to these ordinance provisions (not including variances to the Unified Development Ordinance), or to interpret the meaning of said provisions, so as to relieve such difficulty or hardship; provided that such variances or interpretations do not compromise the architectural or historical integrity of the property. In granting variances, the commission may impose such reasonable and additional stipulations and conditions as deemed necessary. An undue hardship shall not be a situation of the person's own making.

11.3. Criteria for Relocations

In making the determination to approve an application and issue of a certificate of appropriateness (COA) criteria shall be considered by the Community Appearance Board for the act of relocating a structure into, out of, or within the local Historic Design Review District boundaries. The Community Appearance Board will weigh decisions based on findings that

the proposed material change(s) in the appearance would not have a substantial adverse effect on the aesthetic, historic, or architectural significance and value of the structures and historic property in the portion of the historic district which the of which the relocation is being requested.

(From City of Conway Unified Development Ordinance, Article 14.1.3 (H), see Appendix II)

Relocations: *A decision by the CAB approving or denying a certificate of appropriateness for the relocation of a building, structure or object shall be guided by:*

- 1.)** *The historic character and aesthetic interest the building, structure, or object contributes to its present setting.*
- 2.)** *Whether there are definite plans for the area to be vacated and what the effect of those plans on the character of the surrounding area will be.*
- 3.)** *Whether the building, structure, or object can be moved without significant damage to its physical integrity.*
- 4.)** *Whether the proposed relocation site is compatible with the historic and architectural character of the building, structure, site or object.*

11.4. Criteria for Demolitions

In making the determination to approve an application and issue of a certificate of appropriateness (COA) criteria shall be considered by the CAB for the act of demolition within the local historic district boundaries. The commission will weigh decisions based on findings that the proposed material change(s) (i.e. demolition wholesale or in parts) in the appear-

ance would not have a substantial adverse effect on the aesthetic, historic, or architectural significance and value of the structures and historic property in the portion of the historic district for which the demolition is being requested.

(From *City of Conway Unified Development Ordinance*, Article 14.1.3 (I), see Appendix II)

Demolition: *A decision by the CAB approving or denying a certificate of appropriateness for the demolition of buildings, structures, sites, or objects judged to be fifty years old or older, shall be guided by:*

- 1.) *The historic, scenic, or architectural significance of the building, structure, site or object.*
- 2.) *The importance of the building, structure, site or object to the ambiance and/or recorded history of a district.*
- 3.) *The difficulty or the impossibility of reproducing such a building, structure, site or object because of its unique design, texture, material, detail, craftsmanship or location.*
- 4.) *Whether the building, structure, site or object is one of the last remaining examples of its kind in the neighborhood or the city or county.*
- 5.) *Whether there are definite plans for use of the property (provided by the applicant) if the proposed demolition is carried out, and what the effect of those plans on the character of the surrounding area will be.*
- 6.) *Whether reasonable measures can be taken to save the building, structure, site or object from collapse.*
- 7.) *Whether the owner is capable of earning reasonable economic return on the value of a building, structure, site or object (existing or its potential rehabilitated condition).*



Conway, SC 2009

With any building removal gaps in the infrastructure or large vacant parcels of land are left. These can become areas that pedestrians do not cross and can become hot areas in the summer time.

Most well built structures from any era can be rehabilitated. (right) The building being removed for its materials can become a liability on the neighboring buildings (i.e. exposed party-wall interior brick seen in the background). With this facade gone it will create an unpleasant gap in the overall downtown environment.



JB+a Image Archives, 2003

11.5. Stabilization (“Mothballing”) of Structures

If a building becomes vacant or is abandoned, these suggestions can be used to prevent “deterioration by neglect.”

1. Secure. Secure the building against vandalism, break-ins and natural disasters. Apply temporary coverings to window and door openings in such a manner as to not damage historic features or materials.
2. Stabilize. Structurally stabilize the building as needed and provide and maintain a weather-tight roof. Temporary roofing may be installed if needed. Discontinue all utilities and remove flammable materials and debris from the building.
3. Ventilate. Provide adequate ventilation to the interior of the building through the use of vents in the window and door coverings. (Inexpensive air duct covers set over square holes cut in plywood are effective.)
4. Pest Control. The building should be treated to prevent termite infestation and any foundation or eave damage covered with wire screen.
5. Monitor. Periodically monitor the building to insure the effectiveness of the mothballing program.
6. Remove Vegetation. Cut back landscaping or remove any bushes, small trees, and vines that will grow into the foundation, damage structural materials or overtake the building. Visibility lessens trespassers as well.

For additional information, see the National Park Service Preservation Brief: #31: Mothballing Historic Buildings (information on researching NPS Briefs is located in the Appendix, Section VI).

Fig. 6.1: “Mothballing” Measures for Vacant Property



JB+a Image Archives

(Above) This is an example of a potential structure, which given more time in a vacant condition may need to follow a “mothballing” routine. (Below) An illustrated concept of simple mothballing measures.

- Motion Activated Security Lights***
(If power is on)
- Full Plywood Sheets Over Windows***
 - Paint dark gray to give the impression of windows.
 - Use house-trim color to paint 8-inch borders on boards.
- Cut Down Vines & Bushes for Visibility***
- Visible Sales Sign if For Sale or “Pardon Progress” if Possibly Working on Structure***

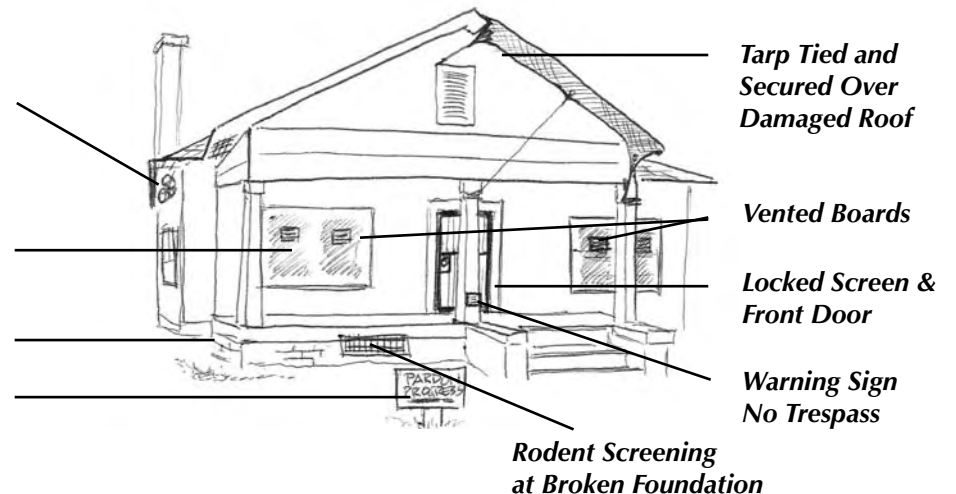

SECTION REF

REFERENCE AND APPENDICES

APPENDIX I:

Glossary of Terms

APPENDIX II:

Historic Preservation Ordinance:

Conway Unified Development Ordinance, Article 14

APPENDIX III:

COA Forms & Requirements for Submission Checklist

Conway Requirements and Process

Other City & Program Forms

APPENDIX IV:

Routine Maintenance Resources

APPENDIX V:

Financial Incentives for Historic Preservation Work

APPENDIX VI:

Hints for a Successful Historic District Business

APPENDIX VII:

Additional Resources for Assistance

APPENDIX I

GLOSSARY OF TERMS

Addition. New construction added to an existing building or structure.

Alligatoring. A slang term that refers to a condition of paint that occurs when too much paint has been applied to a surface over time. The layers crack in a pattern that resembles the skin of an alligator.

Alteration. Work which impacts any exterior architectural feature including construction, reconstruction, or removal of any building or building element.

Apron. The trim under the projecting interior sill of a window.

Arcade. A range of arches supported on piers or columns, generally standing away from a wall and often supporting a roof or upper story. A covered walkway.

Arch. A curved construction which spans an opening and supports the weight above it.

Ashlar. Finished building stone or quarried block often used in the foundation. Usually ashlar has a smooth or tooled finish, though other textures are possible as well.

Awning. A sloped projection supported by a frame attached to the building facade or by simple metal posts anchored to the sidewalk.

Balustrade. A railing or parapet supported by a row of short pillars or balusters.

Bargeboard (gableboard, vergeboard). The decorative board along the roof edge of a gable concealing the rafters.

Bracket. A wooden or stone decorative support beneath a projecting floor, eave, window or cornice.

Bay. The horizontal divisions of a building, defined by windows, columns, pilasters, etc.

Bay window. A window projecting from the body of a building. A "squared bay" has sides at right angles to the building; a "slanted bay" has slanted sides, also called an "octagonal" bay. If segmental or semi-circular in plan, it is a "bow" window.

Belt course. A continuous horizontal band on an exterior wall, usually of projecting masonry. Also called a "string course" and in some instances marks the water table where the top edge of the basement level of a masonry building is identified.

Bond. A term used to describe the various patterns in which brick is laid.

Bracket. A decorative support feature located under eaves or overhangs.

Broken Pediment. A pediment where the sloping sides do not meet at the apex but instead return, creating an opening that sometimes contains an ornamental vase or similar form on a pedestal

Bulkhead. The framed, brick, or otherwise decorative or stylized material area below the display windows. This area is part of the storefront area and acts as a lower, horizontal wide frame edge for the display window. Generally finished in the same hue or color family as the upper window exterior casing, this area might have recessed or projecting panels and trim, but should never detract from the visual activity of the displaying merchandise.

Cantilever. A projecting element, "anchored" in the body of the building, as in the case of a "cantilevered balcony."

Capital. Topmost member, or head, of a column or pilaster. Classical orders (Doric, Ionic, or Corinthian) which define the era or decorative embellishment of the architecture were often reflected in the design of the capital.

Casement. A window in one or two vertical parts mounted on hinges, opening in the center or from one side ("double"-leafed or "single"-leafed).

Certificate of Appropriateness. Once the Community Appearance Board determines that an application for a material change in appearance and/or new construction within a designated local Historic Design Review District (or on property voluntarily put up for review) will not adversely affect the district or the architectural significance of an individual historic resource, a COA is given to the building owner to commence work or apply for a zoning permit with the City, and/or if the proposed work requires a building permit.

Chamfered. When the exterior angle of two surface planes have been cut away or "beveled."

Column. A vertical, cylindrical or square supporting member, usually with a classical capital.

Coping. The top course or capping of a wall which protects it from the effects of weather.

Corbeling. A series of stepped or overlapped pieces of brick or stone usually forming a projecting support in a series of steps from the wall.

Corner Block. A raised square block at the ends of a lintel or apron.

APPENDIX I: GLOSSARY (Continued)

Cornice. The uppermost, projecting part of an entablature, or feature resembling it. This embellishment “caps” the front parapet edge of downtown commercial structures and often in Victorian era facades was made of stamped or formed metal to resemble intricate details and shapes from many classical eras. Cornices can be made of corbelled masonry and can be as simple as a single course of brick, tile, or simply aluminum flashing in mid-to-later 20th century architecture.

Course. A horizontal layer or row of stones or bricks in a wall. This can be projected or recessed. Defined by the arrangement or directional assembly of its parts, such as a “soldier course” defining a row of bricks all set vertically with their stretcher face showing, side to side, while a “header course” is a continuous row of brick with headers side to side.

Crenellation. A low parapet or retaining wall composed of alternating squared blocks and spaces. Originally designed for defensive purposes, this feature was used strictly for decorative purposes during the late 18th and 19th centuries.

Cupola. A dome placed on a circular or polygonal base crowning a roof or turret. It may be large enough to stand inside, venting, or decoration.

Dentil. One of a series of small, square, tooth or block-like projections forming a molding. Another reference is a “dentil course” when used as a banding element on a building.

“Deterioration by neglect.” The willful lack of maintenance, usually preventable, leading to the demise of a historic building.

Dormer. A small window with its own roof projecting from a sloping roof.

Double hung window. A window having two sashes, one sliding vertically over the other.

Efflorescence. A condition of masonry in which white salts from the clay or limes in mortar leach to the surface.

Elevation. Any of the external faces of a building.

Facade. The front elevation or “face” of a building.

Fanlight. A semicircular or semi-elliptical window with radiating muntins suggesting a fan, usually above a door, window or in a gable end wall.

Fascia. A projecting flat horizontal member or molding; forms the trim of a flat roof or a pitched roof; also part of a classical entablature.

Fenestration. The arrangement of window openings in a building.

Finial. A projecting decorative element at the top of a roof turret or gable.

Flashing. Thin metal sheets used to make the intersections of roof planes and roof/ wall junctures watertight.

Footprint. The outline of a building’s ground plan from a top view.

Foundation. The lowest exposed portion of the building wall, which supports the structure above.

Frame construction. A method of construction in which the major parts consist of wood.

Frieze. The middle horizontal member of a classical entablature, above the architrave and below the cornice.

Gable. The triangular upper portion of an end wall, underneath a peaked roof.

Gable roof. A pitched roof with one downward slope on either side of a central, horizontal ridge, forming gables on both ends of the structure.

Gambrel roof. A roof with two sloping planes of different pitch on either side of the ridge; the lower portion is the steeper one.

Gingerbread. Pierced, curvilinear ornament made with a jig or scroll saw, applied to facades or porch column or eave brackets, and railings.

Glazing. Another term for glass or other transparent material used in windows.

Header. A brick laid with the short side exposed, as opposed to a “stretcher.”

Hipped roof. A roof with slopes on all four sides meeting at a ridge or at a single point.

Hood molding. A projecting molding above an arch, doorway, or window, originally designed to direct water away from the opening; also called a drip mold, dripstone, or drip cap.

Infill. New construction where there had been an open lot prior. Applies to a new structure such as a new building between two older structures, inappropriate material such as block infill in an original window opening, or new material such as a wood column inserted to match the profile, placement, and scale of a missing historic iron column.

Jack arch. An arch with wedge shaped stones or bricks set in a straight line; also known as a flat arch.

Jamb. The vertical side of a doorway or window. Keystone. The top or center member of an arch.

APPENDIX I: GLOSSARY (Continued)

Light. A section of a window - single pane of glass (also see glazing).

Light Well. An opening of one or more floors through a roof which allows light to enter the interior of a building.

Lintel. A horizontal beam over a door or window which carries the weight of the wall above; usually made of stone or wood.

Load Bearing. Structural system or wall directly carrying building load.

Mansard. A roof form, or style of attached canopy, with a steeply pitched and, in some cases, concave face and a flattened roof top.

Marquee. A fixed metal and/or glass canopy over the entrance of a building, usually carrying event information over a theatre entrance.

Masonry. Brick, block, or stone which is secured with mortar.

Massing. A term used to define the overall volume of a building.

Meeting Rail. The horizontal location of overlap formed by the juncture between the upper sash and lower sash of a window.

Modillion. A horizontal bracket, often in the form of a plain block, ornamenting, or sometimes supporting, the underside of a cornice.

Mortar. A mixture of sand, lime, cement, and water used as a binding agent in masonry construction. In more recent architecture, or that with harder, "engineered" brick from the 1930s onward, certain mortar mixes can have percentages of Portland cement mixed in for quicker drying and harder bonding (too much so for the softer historic brick). Always test and match the consistency and hardness of any mortar.

Mullion. A heavy vertical divider between windows or doors.

Muntin. A secondary, thin framing member to divide and hold the panes of glass in a window.

National Register of Historic Places. The nation's official list of buildings, sites, and districts which are important in our history or culture. Created by Congress in 1966 and administered by State Historic Preservation Officers (SHPO).

"Ordinary maintenance and repair." Any work, the sole purpose and effect of which is to correct deterioration, decay, or damage, and which does not result in a change in the existing appearance and materials of a property

Oriel. A projecting bay window. Usually on an upper story, it is sometimes supported on brackets.

Palladian window. A window arrangement of three parts; the central and larger window is topped by a round arch. Sometimes referred to as a "Serlian window."

Parapet. A low protective wall located at the edge of a roof.

Patina. The appearance of a material's surface that has aged and weathered. It often refers to the green film that forms on copper and bronze.

Pediment. A triangular crowning element forming the gable of a roof; any similar triangular element used over windows, doors, etc.

Pier. A vertical structural element that "frames" the storefront and is usually clad in the dominant material of the body of the facade. Building piers often cover perpendicular walls of major interior divisions.

Pilaster. A pier attached to a wall, often with capital and base.

Pitch. A term which refers to the steepness (degree) of roof slope.

Pointing or "Tuck Pointing." The process of scraping out failing mortar between bricks back to a stable point and re-troweling new mortar that matches the make up, color, and mixture of the original mortar. Done correctly, only the failing areas need treatment and the mortar can be tinted to match the original or allowed to weather. (See also Portland cement.)

Portico. A roofed space, open or partly enclosed, forming the entrance and centerpiece of the facade of a building, often with columns and a pediment.

Portland cement. A strong, inflexible (too much so for historic buildings) hydraulic cement used to bind mortar. (Much like gray sidewalk cement.) As opposed to softer lime-based historic mortar generally a certain proportion of lime sand and water. Always match new mixes of mortar to match that of the original mortar content.

Prism Glass. (Also sometimes known as "art glass" or "leaded glass") Panes of glass usually found in the storefront transom area, set with leading, that is designed to reflect diffused light rays (into the interior of the business).

Quoins. Decorative blocks of stone or wood used on the corners of buildings.

Recessed panel. A decorative element that often functions as an area for signage.

APPENDIX I: GLOSSARY (Continued)

Repoint. To remove old mortar from courses of masonry and replace with new mortar OF THE SAME KIND and hardness. This is standard maintenance on brick buildings, done with quality materials may be required every 100+ years, or as needed.

Reveal. The depth of wall thickness between its outer face and a window or door set in an opening.

Rising Damp. A condition in which moisture from the ground rises into the walls of a building.

Sash. The operable portion of a glazed window that holds the glass and usually moves up or down in side tracks and held in place by counter-balanced weights, springs, or metal compression channels. See also "double-hung window."

Scale. A term used to define the proportions of a building in relation to its surroundings.

Segmental Arch. A round arch whose curve is less than that of a semi-circle.

Setback. The distance a building is located from the front edge of its lot line (or a street or sidewalk).

Sidelight. A glass window pane located at the side of a main entrance way.

Siding. The exterior wall covering or sheathing of a structure.

Sign Band. The area that is incorporated within or directly below the cornice of a storefront (see storefront) and that contains the Primary Sign of the business in the building.

Sill. The horizontal member located at the top of a foundation supporting the structure above; also the horizontal member at the bottom of a window or door.

Spalling. A condition in which pieces of masonry (or brick face) split off from the surface usually caused by weather or the improper addition of repointed mortar that is too hard (Portland cement) for the older, softer brick walls.

Storefront. Area between the building piers, pillars, or pilasters that is generally mostly glass and wood framing for the essential purpose of interacting with the public, selling goods in display windows, and providing entry to the interior of the building. Usually contains its own storefront cornice to visually divide the area from the upper façade and provide

space for signage. This area can also have its own set of transom windows running above or below a projecting awning. Often this is the area of the façade that undergoes the greatest amount of stylistic and physical change due to the nature and audience of the retail business.

Streetscape. The combination of building facades, sidewalks, street furniture, etc. that define the street.

Stretcher. A brick laid with the long side exposed, as opposed to a "header."

String Course. A projecting band of masonry running horizontally around the exterior of a building, also referred to as a "belt course."

Studs. Upright framing members of a wood building.

Stucco. Any kind of plaster work, but usually an outside covering of Portland cement, lime, and sand mixture with water.

Surround. An encircling border or decorative frame, usually around a window or door.

Terra Cotta. Glazed or unglazed clay that has been cast and fired and is used as decorative elements on surfaces and around openings of buildings.

Transom. In commercial buildings it is the area of windows in the storefront (see storefront) above the display windows and above the shop door. In residential or commercial structures it can be an additional small operable or fixed window located above a window or door. (Often mullions align with the divisions of lights in the window below and the profiles of the mullions match, or the transoms are set with prism or art glass.)

Valance. In commercial buildings it is the edge or border area of an awning, in fabric that usually hangs loose with a scalloped or straight edge. Sometimes a Secondary Sign or Subordinate Sign information (such as address) may be placed within this panel.

Weatherboard. Wood siding, usually overlapped, placed horizontally on wood-frame buildings. Often "beaded," that is, finished with a projecting, rounded edge.

Wrought iron. Decorative iron that is hammered or forged into shape by hand, as opposed to cast iron which is formed in a mold.

APPENDIX II

Conway Unified Development Ordinance Articles

Excerpted Articles from the UDO providing for historic preservation, historic design review and the establishment and procedures of the CAB.

**STATE OF SOUTH CAROLINA
COUNTY OF HORRY
CITY OF CONWAY**

SELECTED EXCERPTS FROM ARTICLE 14: (as adopted Dec. 12, 2011)

**THE UNIFIED DEVELOPMENT ORDINANCE OF THE CITY
OF CONWAY, SOUTH CAROLINA,**

Article 14.1.1 Community Appearance Board

The Community Appearance Board is composed of seven (7) members appointed by the Conway City Council. The Board is created to serve as an architectural review board as authorized by SC § 6-29-870. It is the declared policy of the City Council that it will consider and approve only those persons who have demonstrated their civic interest, general knowledge of the community, independent judgment, and ability to prepare for and attend meetings.

Membership of the Board shall at all times include not less than one (1) nor more than two (2) members who are serving in professionally designated seats as AIA-certified architects. The person serving in the designated licensed architect or landscape professional seat is permitted to serve beyond the maximum term limit until a replacement member meeting the professional designation qualifications is found. All other members of the CAB shall have a demonstrated interest in, and/or competence and knowledge of, architecture, landscape architecture, and urban design.

Article 14.1.2 Duties and Powers

A. Historic Design Review Districts (HDRDs)

1. The Community Appearance Board will have specific duties pertaining to Conway’s local, Historic Design Review Districts (authorized by SC § 6-29-870) in which it is the CAB’s duty to:

a. To protect and promote the appearance, character, and economic value of all development located within the Main Street Corridor Historic Design Review District, Downtown Commercial Historic Design Review District, and Waccamaw Riverfront Historic Design Review District. This shall be accomplished through the issuance of Certificates of Appropriateness (COAs) for the building or property owner to commence work or apply for a zoning permit with the City, and/or if the proposed work requires a building permit.

b. To oversee the survey and inventory of historic properties, and assure the survey is conducted in accordance with the professional standards which are complementary to the standards of the State Historic Preservation Office.

c. To recommend the designation and nomination of buildings, structures, sites, objects, districts, or individual property to the State Board of Review for inclusion in the National Register.

d. To recommend to City Council the inclusion of additional historic districts and the expansion of the size of existing historic districts.

e. To review, and approve or deny, all applications for proposed new commercial developments to be located within the Main Street Corridor Historic Design Review District, Downtown Commercial Historic Design Review District, and Waccamaw Riverfront Historic Design Review District.

f. To review, and approve or deny, all applications for alterations and/or additions to existing commercial developments to be located within the Main Street Corridor Historic Design Review District, Downtown Commercial Historic Design Review District, and Waccamaw Riverfront Historic Design Review District.

g. To review and approve or deny, all applications for permits to build, alter, or demolish any building or structure located within the Main Street Corridor Historic Design Review District, Downtown Commercial Historic Design Review District, and Waccamaw Riverfront Historic Design Review District.

h. To review, approve or deny, landscape plans for all developments within the Main Street Corridor Historic Design Review District, Downtown Commercial Historic Design Review District, and Waccamaw Riverfront Historic Design Review District.

i. To review, approve or deny, landscape plans proposed by the City of Conway or any other state or federal agency for public rights-of-way or for publicly owned property located within the Main Street Corridor Historic Design Review District, Downtown Commercial Historic Design Review District, and Waccamaw Riverfront Historic Design Review District.

j. To review, and approve or deny, architectural plans for facilities proposed by the City of Conway or any other state or federal agency to be located within the Main Street Corridor Historic Design Review District, Downtown Commercial Historic Design Review District, and Waccamaw Riverfront Historic Design Review District.

k. The CAB will act as the official “reviewing authority” for the City of Conway to review, and approve or deny, all applications for a 15-year Local Property Tax Abatement incentive offered through Conway’s adoption of state authorizing legislation (Sections 4-9-195 and 5-21-140, SC Code of Laws, 1976, as amended). The process will require full CAB review procedures for any owner-occupied residence or income-producing building located within any locally designated Historic Design Review District, National Register Historic District, those properties listed individually to the National Register of Historic Places, or any other building 50-years old, or older, within the City limits, that an owner voluntarily submits their planned work through said review. Official approval must be stated by the CAB in writing to the Conway Planning Department that the proposed and completed rehabilitation work is appropriate for the (historic) building in question and/or the historic district in which it is located, and verify that individual expenditures for rehabilitation have exceeded the locally designated minimum expenditure of 25% of the fair market value of the building.

(Note: Ordinance shown for reproduction purposes only and not to scale. Rev. 12-2011 and may not reflect recent amendments. Continued on next page.)

APPENDIX II: Conway UDO Articles (Continued)

2. The purpose of establishing each Historic Design Review District is to protect and enhance the aesthetic and visual character of each individual district and all development in the traditional, established portions of the City of Conway. This will provide for economic growth and stability through the preservation of property values. The design review process is not intended to stifle innovative architecture but to assure respect for surrounding uses and reduce incompatible and adverse impacts on the visual experience and irreplaceable building resources. To accomplish this, the Community Appearance Board has produced the “Historic Design Review Districts: Community Appearance Guidelines” to aid in reviewing proposed work to existing structures, site improvements, signs, and landscaping, in addition to those standards pertaining to the particular base zoning district in which the development occurs.

a. The boundaries of the Historic Design Review Districts shall include all parcels located in the Main Street Corridor Historic Design Review District, Downtown Commercial Historic Design Review District, Waccamaw Riverfront Historic Design Review District.

b. Once the Community Appearance Board determines that an application for a material change in appearance and/or new construction within a designated local Historic Design Review District (or on property voluntarily put up for CAB review) will not adversely affect the Historic Design Review District or the architectural significance of an individual historic resource, a Certificate of Appropriateness (COA) is given to the building owner to commence work or apply for a zoning permit with the City, and/or if the proposed work requires a building permit. Such required Historic Design Review process shall be in accordance with the Requirements set forth in Section 14.1.3 and Design Review Procedures set forth in Section 14.1.5(D.1).

c. No zoning permit shall be issued for the alteration of the existing conditions of the lands, uses, or structures within the Historic Design Review District except in accordance with the requirements stated herein. This includes construction of new structures, renovations to existing structures, installation of new or replacement signage, and removal of trees and/or natural vegetation. The CAB will review changes being proposed to the form or appearance of an existing resource that can be seen from the public right-of-way in the Main Street Corridor Historic Design Review District and on proposed changes (or new construction) of all sides of structures in the Downtown and Waccamaw Riverfront Historic Design Review Districts. The Community Appearance Board may waive the design review requirements if a portion of the project will not be visible from a public right-of-way once the project is completed.

d. Prior to the issuance of a Certificate of Appropriateness to obtain a City zoning permit, applicants shall submit two copies of all relevant information deemed necessary by the Community Appearance Board and/or the Planning Director in order for the Board to approve or deny the application. Relevant information may include but shall not be limited to site plans illustrating the location of existing structures and proposed new structures and/or additions; landscape plans illustrating the location of existing landscaping and proposed new landscaping; building designs and facade drawings of the front, sides, and rear of all proposed new structures and/or facades proposed to be renovated; plans for existing signage and proposed new signage; color samples of paint, brick, shingles, siding; topographic surveys; tree surveys; and lighting plans. Such required plans shall be submitted in accordance with the requirements set forth in Section 14.1.4.

B. Local Historic Register of Individual Properties

Based on the criteria below, individual properties that have been requested by the property owner(s) to be added to the City of Conway Historic Property Register shall be reviewed by the CAB and a recommendation forwarded to the Conway City Council for the consideration of approval. These records shall be held in the City of Conway Planning Department and made available to the public. The process of review shall include property owner notification and a public hearing. See Section 13.1.7.

1. Designation: If the owner(s) of the property initiate the request, the CAB shall make recommendations for historic properties for local historic designation to the Conway City Council based on one (1) or more of the following criteria:

- a. Has significant inherent character, interest, history, or value as part of the community or heritage of the community, state, or nation; or
- b. Is the site of an event significant in history; or
- c. Is associated with a person or persons who contributed significantly to the culture and development of the community, state, or nation; or
- d. Exemplifies the cultural, political, economic, social, ethnic, or historic heritage of the community, state, or nation; or
- e. Individually, or as a collection of resources, embodies distinguishing characteristics of a type, style, period or specimen in architecture or engineering; or
- f. Is the work of a designer whose work has influenced significantly the development of the community, state, or nation; or
- g. Contains elements of design, detail, materials, or craftsmanship which represent a significant innovation; or
- h. Is part of or related to a square or other distinctive element of community planning; or
- i. Represents an established and familiar visual feature of the neighborhood or community; or
- j. Has yielded, or may be likely to yield, information important in pre-history or history.

Article 14.1.3 Historic Design Review and Community Appearance Requirements

A. Purpose

1. This section establishes requirements for the comprehensive review of development to implement the goals and policies of the City of Conway’s Comprehensive Plan and the “Historic Design Review Districts: Community Appearance Guidelines”, which shall also be referred to the Community Appearance Guidelines in this Article.

B. Applicability of Historic Design Review

1. All projects that require a land use or building permit or will affect the exterior appearance and/or new construction of any building or property within Conway’s local Historic Design Review Districts shall be subject to Historic Design Review in compliance with Article 14.1.2(A) and this

(Note: Ordinance shown for reproduction purposes only and not to scale. Rev. 12-2011 and may not reflect recent amendments. Continued on next page.)

APPENDIX II: Conway UDO Articles (Continued)

Article. Property owners located in the Conway Residential National Register Historic District, only, are recommended to follow the Community Appearance Guidelines, on a voluntary basis.

2. In addition, public projects such as sidewalk installation and other streetscape and pedestrian / bicycle improvement projects within the historic districts shall be subject to Community Appearance Board review.
3. In addition, projects that require a land use or building permit or will affect the exterior appearance and/or new construction of any building or property that meet the requirement for “Voluntary Historic Property Review” shall be subject to Historic Design Review in compliance with this Article and may gain additional local tax benefits offered by the City (see Article 14.1.3(G) below).

C. Building permits.

1. No City Zoning Permit, and/or if the project requires a City building permit, shall be issued for any project until the project has been evaluated through the Community Appearance Board Review process and a Certificate of Appropriateness with appropriate permits has been issued.

D. Requirement for a Certificate of Appropriateness

1. Any articles of this Unified Development Ordinance (UDO) related to historic preservation shall pertain to the exterior material appearance of a building, structure, work of art, and site as a whole, or a combination thereof. Upon designation and inclusion of a district or individual landmark within the Historic Design Review Districts, a Certificate of Appropriateness shall be issued by the Community Appearance Board for work on projects prior to the issuance of a zoning and/or building permit for any material change in the exterior appearance of a structure or site, and or new construction.
2. A property owner may voluntarily submit their property to the Community Appearance Board for a full Historic design review (see Article 14.1.3(G) below). More information may be found in the Community Appearance Guidelines, Section A (Chapter 2.2), “Certificate of Appropriateness Approval Matrix.”

E. Amendments to the Historic Design Review Districts

1. Local designations for historic districts or individual landmarks may be proposed to be established or proposed to be rescinded by the City Council, the Community Appearance Board, the Planning Staff, and the property owner(s). Local designations shall be considered as amendments to the Historic Design Review Districts. The City Council is the authoritative body that approves and adopts the historic design review district additions and/or boundary changes.
2. The Historic Design Review Districts and Historic Design Review Maps may be amended from time to time to include new or separate, non-contiguous designated historic districts, to modify existing local historic districts, to designate historic landmarks, or for other reasons, provided such an amendment conforms to the provisions of this Article.

F. Affirmation of Building Regulations and Community Appearance Guidelines

1. Nothing in this section shall be construed so as to exempt property owners or occupants from complying with applicable building codes, nor prevent any property owners or occupant from making use of the property not prohibited by other statutes, ordinances, or regulations.
2. The City of Conway “Historic Design Review Districts: Community Appearance Guidelines” are standards for evaluating proposed material changes to structures located within Historic Design Review Districts. These guidelines are intended to offer guidance to owners and occupants, architects, developers, and other individuals contemplating restoration, remodeling, or new construction on how to maintain the architectural integrity of the structure and district as a whole.
3. The Community Appearance Board shall review and make recommendations to City Council to amend the Community Appearance Guidelines. The Community Appearance Guidelines shall be approved and adopted by City Council. Nothing in this section shall be construed so as to exempt property owners and occupants from complying with applicable design and construction guidelines.

G. Voluntary Historic Property Review Requirement

1. A property owner may choose to follow the standards of the Community Appearance Guidelines and comply with the full requirements and procedures of Historic Design Review for additional local tax benefits (inquire with Conway Planning Department for more information) or other purposes, if the following items are applicable:
 - a. The structure being reviewed is fifty (50) years or older;
 - b. The structure is a current contributing structure to one of Conway’s National Historic Register Districts as recorded in the National Register of Historic Places with the National Park Service of the United States;
 - c. The structure is currently individually listed on the National Register of Historic Places with the National Park Service of the United States.

H. Criteria for Relocations

1. A decision by the Community Appearance Board approving or denying a Certificate of Appropriateness for the relocation of a building, structure, or object shall be guided by:
 - a. The historic character and aesthetic interest of the building, structure, or object contributes to its present setting.
 - b. Whether there are definite plans (provided by the project applicant) for the area to be vacated and what the effect of those plans on the character of the surrounding area will be.
 - c. Whether the building, structure, or object can be moved without the significant damage to its physical integrity.
 - d. Whether the proposed relocation is compatible with the historic and architectural character of the building, structure, site, or object.

APPENDIX II: Conway UDO Articles (Continued)

I. Criteria for Demolition

1. A decision by the Community Appearance Board approving or denying a Certificate of Appropriateness for the Demolition of buildings, structures, sites or objects (judged to be fifty (50) years old or older) shall be guided by:
 - a. The historic, scenic, or architectural significance of the building, structure or object.
 - b. The importance of the building, structure, site or object to the ambiance and/or recorded history of a district
 - c. The difficulty or impossibility of reproducing such a building, structure, site or object because of its unique design, texture, material, detail, craftsmanship or location.
 - d. Whether the building, structure, site or object is one of the last remaining examples of its kind in the neighborhood, district, city, county or nation.
 - e. Whether there are definite plans for use of the property (provided by the project applicant) if the proposed demolition is carried out and what the effect of those plans on the character of the surrounding area will be.
 - f. Whether reasonable measures can be taken to save the building, structure, site or object from collapse.
 - g. Whether the building, structure, site or object is capable of earning reasonable economic return on its value (existing or potential rehabilitated condition).
 - h. The protection of historic trees shall meet the City of Conway Tree Preservation Ordinance.

J. Variances for Undue Hardship

1. Where, by reason of unusual circumstances, the strict application of any provision of this Article would result in the exceptional practical difficulty or undue hardship upon any owner of a specific property, the Community Appearance Board shall have the power to vary strict adherence to said provisions, or to interpret the meaning of said provisions, so as to relieve such difficulty or hardship; provided that such variances or interpretations do not compromise the architectural or historical integrity of the property. In granting variances, the Community Appearance Board may impose reasonable and additional conditions as deemed necessary. Any undue hardship shall not be a situation of the person's own making.
2. Within sixty (60) days after receiving written notification from the CAB of the denial of a Certificate of Appropriateness for a proposed alteration or construction, an applicant may seek relief on the ground of hardship pursuant to this section. In order to prove the existence of hardship, the applicant shall establish that the property, without the owner's proposed alteration, is incapable or earning a reasonable return, regardless of whether that return represents the most profitable return possible. The applicant shall have an opportunity to demonstrate undue hardship if the CAB approves a request with additional conditions and additional work to be provided.
3. An application for a Certificate of Appropriateness on the grounds of hardship shall include:
 - a. A verifiable estimate of the cost of the proposed construction or alteration and an estimate of any additional cost that would be incurred to comply with the recommendations of the CAB for changes necessary for the issuance of a Certificate of Appropriateness.

- b. An estimate of the market value of the property in its current condition; and after completion of the proposed construction or alteration and after renovation of the existing property for continued use.
 - c. Any listing(s) of the property for sale or rent, price asked and offers received, if any, within the previous two years.
 - d. The assessed value of the property according to the two most recent Horry County assessments; and
 - e. An indication of the form of ownership or operation of the property, whether sole proprietorship, for-profit or not-for-profit corporation, limited partnership, joint venture, or other.
 - f. Any other information the CAB needs in order to make its hardship decision.
4. The CAB shall act on the hardship application at a public meeting of the CAB, at which time an opportunity will be provided for proponents and opponents of the application to present their views.
5. The applicant shall consult in good faith with the CAB, local preservation groups, and interested parties in a diligent effort to seek an alternative that will result in preservation of the property.
6. All decisions of the CAB should be within forty-five (45) days of the submission to the CAB of the completed application and shall be in writing. A copy of any CAB decision shall be sent to the applicant by mail, with a copy forwarded to the Planning Director. The CAB's decision shall state the reasons for granting or denying the hardship application. If the CAB does not act on the application within forty-five (45) days, the hardship application shall be deemed denied.
7. No exterior building permit or demolition permit shall be issued while the hardship application is pending. The CAB shall make a determination on whether a hardship exists. Building and demolition permits shall be issued in accordance with that determination but for only such work as is necessary to alleviate the hardship.
8. A person who may have substantial interest in any decision of the Community Appearance Board or any officer or agent thereof may appeal to the circuit court in Horry County, SC (filed within 30 days after the decision of the CAB), which is referenced in SC Code 6-29-900.

K. Maintenance of Historic Properties

1. Ordinary maintenance and repair is any work, the sole purpose and effect of which is to correct deterioration, decay, or damage, and which does not result in a change in the existing appearance and materials of a property. The Conway Community Appearance Board has the authority to determine whether or not the definition of ordinary maintenance and repair applies to any given project or application for design review. Ordinary maintenance and repair does not require the approval of a Certificate of Appropriateness. Some ordinary maintenance and repair may still require a City building permit application. Examples of this type of work can be found in the Community Appearance Guidelines, Section A (Chapter 2.2), "Certificate of Appropriateness Approval Matrix".
2. Property owners of individual properties within a designated historic district or of designated historic landmarks shall not allow their buildings to deteriorate by failing to provide ordinary maintenance or repair. The Community Appearance Board shall be charged with the responsibilities regarding "deterioration by neglect" (the willful lack of maintenance, usually preventable, leading

(Note: Ordinance shown for reproduction purposes only and not to scale. Rev. 12-2011 and may not reflect recent amendments. Continued on next page.)

APPENDIX II: Conway UDO Articles (Continued)

to the demise of a historic building) without known Variance for Undue Hardship, in the following cases below.

a. Notice to owner to remedy. If the Community Appearance Board determines a property owner has failed to provide ordinary maintenance or repair (including but not limited to damaged windows, doors, siding, foundation, or roof structure), the Community Appearance Board shall deem (by majority vote) that Planning Department staff notify the property owner and set forth the steps which need to be taken to remedy the situation. The property owner shall have 180 days in which to resolve the situation.

b. Failure by owner to remedy. If the condition is not remedied within 180 days, the owner shall be subject to the enforcement provisions as specified in Article 15 or upon authorization and at the direction of the City Council. The Community Appearance Board shall make the determination of what means are necessary to remedy this situation and prevent deterioration by neglect. The property owner shall be liable for the cost of such maintenance or repair. The cost of such maintenance or repair shall be a lien against the real property. The lien shall attach to the real property at the time of payment of all costs of maintenance or repair by the City of Conway.

Article 14.1.4 Site Design and Architectural Plan Submittals

A. Site plans

Site plans shall meet all applicable zoning requirements including but not limited to setbacks, parking, and landscaping. In addition the Community Appearance Board shall review site plans in order to insure compliance with the following standards.

1. Proposed development shall avoid excessive or unsightly grading, indiscriminate earth moving or clearing, and removal of trees and vegetation which could cause disruption of natural water courses or disfigure natural land forms.
2. Proposed development shall be located and configured in a visually harmonious manner with the terrain and vegetation of the subject parcel and with that of surrounding parcels.
3. Where it is reasonable and practical, proposed structures shall not impede scenic views from the main road, from existing structures, or from natural settings.

a. Although maximum site densities and special site requirements defined for particular zoning categories in the Unified Development Ordinance shall be preserved, proposed structures shall not dominate an adjacent building or surrounding development in an incompatible manner.

b. The landscape plans for the proposed development shall provide visually harmonious and compatible settings for structures on the same lot and on adjoining or nearby lots and shall blend with the surrounding natural landscape. Extreme care shall be given to the preservation of existing natural vegetation on the site and shall be incorporated into proposed landscape plans.

c. Plant materials shall be selected and placed with regards to the estimated mature height and width of such materials.

B. Architectural Design Standards

Structures shall meet all applicable Building Code requirements. In addition the Community

Appearance Board shall review building design and materials in order to insure compliance with the City of Conway’s visual character.

Article 14.1.5 Design Review Procedures for Applicants and Application Process

A. Appearances

The applicant of any party in interest may appear in person or by agent. The Board may postpone or proceed to dispose of a matter on the records before it in the absence of an appearance on behalf of any applicant.

B. Calendar

Applications shall be marked with the date of receipt and placed on the hearing calendar in the order in which received. Applications shall be heard in the order on the calendar unless otherwise set by the Board for good cause shown.

C. Submittal of Information

Applicants shall submit all information deemed necessary by the Community Appearance Board in order for the board to approve or deny the application. The deadline for applicant’s submittals will be ten (10) days prior to the CAB meeting in order to be placed on that meeting’s agenda.

D. Community Appearance Board Application Review Process

1. Design Review Procedures for Historic Design Review Districts that require Certificates of Appropriateness (Depending on the level of work proposed based on the matrix found in the Introduction Section A of the “Historic Design Review Districts: Community Appearance Guidelines”, the CAB will allow the Planning Department staff to suggest a non-public, Administrative Approval with the CAB knowledge and signed agreement for a quicker issuance of a Certificate of Appropriateness for a Zoning Permit.)

a. **Conceptual Review.** Applicants are encouraged to meet with the Planning Director prior to the preparation of working drawings and specifications. The purpose of the meeting shall be to familiarize applicants with the City of Conway Community Appearance Board and the “Historic Review District: Community Appearance Guidelines.” Applicants may meet with the Community Appearance Board to review a general design concept of a proposed project.

b. **Preliminary Review.** The Community Appearance Board shall review each application to determine if it adheres to the design review criteria. If the design and materials are consistent with the design guidelines, the Board may grant final approval. If revisions are required, the applicant shall make the necessary revisions and submit them for a final review.

c. **Final Review.** Once the Community Appearance Board has determined that an application satisfies all design guidelines, the Board may approve the issuance of a Certificate of Appropriateness.

(End of excerpt of Article 14 for Appendix II. Full Article and most recent version of Unified Development Ordinance may be obtained at Conway Planning Department.)



City of Conway

Community Appearance Board

APPLICATION / CERTIFICATE OF APPROPRIATENESS

Staff Use Only
Received: _____
Staff: _____
Inspected: _____

City of Conway Planning Department Phone: (843) 488-9888
 206 Laurel Street, 29526 Conway, South Carolina

FAX: (843) 488-9890
www.cityofconway.com

Property Address:		TMS#:
Review Request:	Project Type:	HDRD:
Conceptual Preliminary Final	Alterations / Additions New Construction Signs Landscape Color Change	Miscellaneous (Fencing, roofs, etc) Demolition / Moving of Structure Repairs / Repainting with no Change Appeal the Decision of Planning Staff
Property Owner:	Daytime phone:	
Applicant:	Daytime phone:	
Applicant's mailing address:	Applicant's e-mail address:	
City:	State:	Zip Code:
Applicant's relationship:	Owner	Design Professional
Value of Project (As noted on Building Permit): \$	Contractor	Real Estate Broker
In your own words, describe what you are requesting:		

<p>Submittal Requirements: (See attached CAB Requirements) ***Digital copies of all supporting materials must be submitted along with two hard copies:</p> <ul style="list-style-type: none"> Zoning approval obtained and/or initial TRC review completed Completed CAB application Two (2) copies of all relevant information (As deemed necessary by CAB and/or Planning Director) Site plans illustrating of existing structures and proposed new structures and/or additions Landscape plans illustrating the location of existing landscaping and proposed new landscaping; 	<ul style="list-style-type: none"> Building designs and facade drawings of the front, sides, and rear of all proposed new structures and/or facades proposed to be renovated; Plans for existing signage and proposed new signage; Color samples of paint, brick, shingles, siding; Topographic surveys; Tree surveys; Lighting plans; Specifications for miscellaneous architectural elements (lighting fixtures, hardware and finishes, etc.)
---	--

I hereby acknowledge by my signature below that the foregoing application is complete and accurate and that I am the owner of the subject property or the authorized representative of the owner. I authorize the subject property to be inspected, and that all required material will be submitted to the City of Conway Planning Department no later than ten (10) days prior to the meeting date. The Community Appearance Board meets the second and fourth Wednesday of each month at 4:00 P.M. in City Hall, 229 Main Street. I understand that it is my responsibility to obtain all necessary approvals from other city departments, and that all zoning requirements must be satisfied prior to the project's being placed on a Community Appearance Board agenda. **A REPRESENTATIVE MUST BE PRESENT AT THE MEETING TO HAVE YOUR REQUEST HEARD.**

Applicant's signature: _____ **date:** _____

Print name legibly: _____



City of Conway

Community Appearance Board

APPLICATION / CERTIFICATE OF APPROPRIATENESS

REQUIREMENTS AND PROCEDURES

Sign Permit Procedures

Application to erect, alter, or relocate a sign shall be made to the City Planner upon a form provided by the City Planner and **shall include the following information. Applicants shall submit two (2) copies of all relevant information as follows:**

1. Name, address, telephone number, and signature of the owner of premises (and occupant if different) granting permission for the construction, maintenance, or display of the proposed signage.
2. Name, address, telephone number, and signature of sign contractor.
3. The approximate value of the project/sign to be installed, including the installation cost.
4. Two copies of a sketch or blue print of the proposed signage drawn to scale, showing elevations of the sign as proposed on the building facade, awning, or canopy. In the case of a freestanding sign, a sketch plan of the property drawn to scale illustrating the proposed location of the sign.
5. Specifications and scaled drawings showing the materials, design, dimensions, structural supports, and electrical components of the proposed sign.
6. Any other information, specifications, photographs, or the like deemed necessary by the Planning Department staff in order to assure compliance with requirements set forth herein.

New Construction/Additions/Alterations

Prior to the issuance of a zoning permit, **applicants shall submit two (2) copies of all relevant information** deemed necessary by the Community Appearance Board and/or the Planning Director in order for the Board to approve or deny the application. **Relevant information may include but shall not be limited to:**

1. site plans illustrating the location of existing structures and proposed new structures and/or additions;
2. landscape plans illustrating the location of existing landscaping and proposed new landscaping;
3. building designs and facade drawings of the front, sides, and rear of all proposed new structures and/or facades proposed to be renovated;
4. plans for existing signage and proposed new signage;
5. color samples of paint, brick, shingles, siding, etc.;
6. topographic surveys;
7. tree surveys;
8. lighting plans.
9. Specifications for miscellaneous architectural elements (lighting fixtures, hardware and finishes, etc.)

Definitions

- A. **Conceptual Review:** Applicants are encouraged to meet with Planning Department staff prior to the preparation of working drawings and specifications. The purpose of the meeting shall be to familiarize applicants with the City of Conway Community Appearance Board and the design review standards. Applicants may meet with the Community Appearance Board for a tentative reaction to the general design concept of a proposed project.
- B. **Preliminary Review:** The Community Appearance Board shall review each application to determine if it adheres to the design review criteria. If the design and materials are consistent with the design guidelines, the Board may grant final approval. If revisions are required, the applicant shall make the necessary revisions and submit them for a final review.
- C. **Final Review:** Once the Community Appearance Board has determined that an application satisfies all design guidelines, the Board may approve the issuance of a COA (Certificate of Appropriateness).



City of Conway
 Community Appearance Board
 APPLICATION / CERTIFICATE OF APPROPRIATENESS

DESIGN REVIEW PROCESS AND FLOW CHART

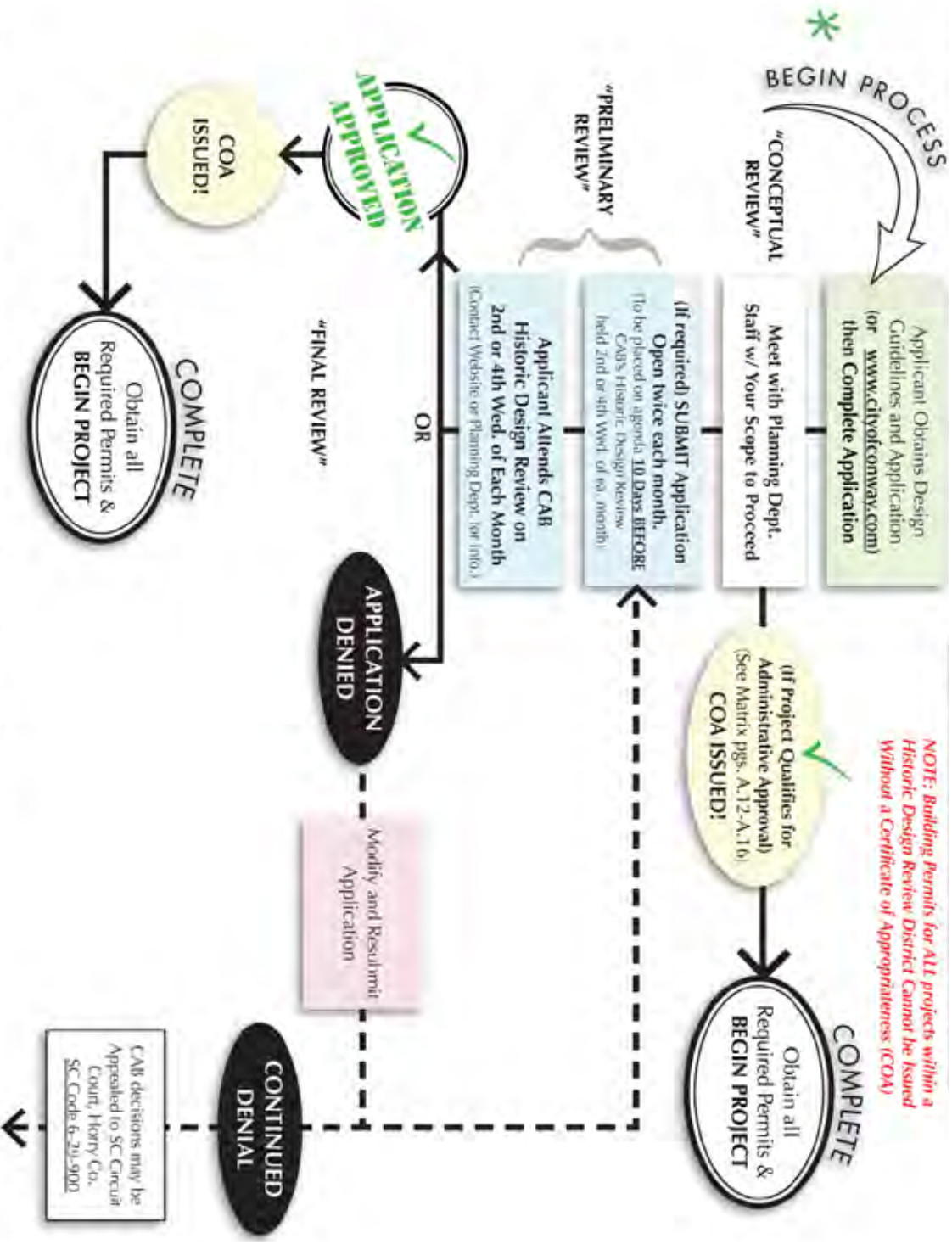



Central Business District Incentive Program Application

PHYSICAL ADDRESS OF PROPERTY: _____ TMS#: _____

BUILDING PERMIT FEES PAID () YES () NO AMOUNT: _____ DATE PAID: _____

BUSINESS LICENSE FEES PAID () YES () NO AMOUNT: _____ DATE PAID: _____

HOW LONG WAS BUILDING VACANT BEFORE OCCUPIED: _____

NAME OF APPLICANT: [PRINT] _____ PHONE # _____

IS THIS A NEW BUSINESS () YES () NO IF NO, WHERE PREVIOUSLY LOCATED: _____

MAILING ADDRESS OF APPLICANT: _____

NAME OF PROPERTY OWNER(S): [IF DIFFERENT FROM APPLICANT] _____

PHONE # _____

MAILING ADDRESS OF PROPERTY OWNER(S) [IF DIFFERENT FROM APPLICANT]: _____

DESIGNATION OF AGENT [COMPLETE ONLY IF OWNER IS NOT THE APPLICANT]

I (we) hereby appoint the person named as applicant as my (our) agent to represent me (us) and act on my (our) behalf in this request for rezoning.

PROPERTY OWNER'S SIGNATURE(S) _____ DATE _____

I (we) the applicant do hereby certify that all information presented in this zoning map amendment application is correct.

APPLICANT'S SIGNATURE _____ DATE _____

CITY APPROVAL

Planning Director: _____ Chief Building Official: _____

Finance Director: _____ City Administrator: _____



PLANNING DEPARTMENT
206 LAUREL STREET
CONWAY, SC 29526

TEMPORARY BUSINESS EVENT SIGN PERMIT

Applicant Name: _____
Date of Event: _____
Property Address: _____
Business Name: _____
Contact Number: _____
Fax Number: _____
Request: _____

****OFF PREMISES SIGNS ARE PROHIBITED****

Temporary Business Sign: _____
Size (not more than 24 Sq Ft) _____
Height (not more than 15') _____
Dates (must not exceed 7 consecutive days) _____
Type (wall, freestanding, banner) _____
Location (must be located on-site) _____

Please note: There shall not be more than two (2) permits for temporary business event signs issued for the same business location within one (1) calendar year.

Date Sent to Planning Department for Review: _____
Applicant Signature: _____
Zoning Administrator: _____ Recommended Action: _____

Telephone (843) 488-9888 FAX (843) 488-9890
www.cityofconway.com

Street Tree Requirements

All developments which require the installation of sidewalks as set forth in the City of Conway Land Development Regulations shall be required to install street trees in the public right of way (50') feet intervals. ***These trees must be installed before a Certificate of Occupancy will be issued.***

Shade trees: Any deciduous or leaf being tree that reaches a mature height in excess of forty (40) feet. Shade trees shall be a minimum of three (3) inches in caliper and twelve (12) to fourteen (14) feet in height at the time of installation.

A. Shade trees:

Common Name	Botanical Name
American Beech	Fagus grandifolia
Bald Cypress	Taxodium distichum
Black Gum	Nyssa sylvatica
Elm	Ulmus americana
Hickory	Carya ovata
Laurel Oak	Quercus laurifolia
Live Oak	Quercus virginiana
Palmetto	Sabal palm
Pecan	Carya illinoensis
Pin Oak	Quercus palustris
Red Cedar	Juniperus virginiana
Red Maple	Acer rubrum
Red Oak	Quercus falcata
River Birch	Betula nigra
Southern Magnolia	Magnolia grandiflora
Southern Sugar Maple	Acer barbatum
Sweet Gum	Liquidambar styraciflua
Sycamore	Plantanus occidentalis
Tulip Poplar	Liriodendron tulipifera
Water Oak	Quercus nigra
White Oak	Quercus alba
Willow Oak	Quercus phellos
Zelkova	Zelkova serrata

I understand that these trees must be installed before a Certificate of Occupancy will be issued.

Signature of Contractor/Authorized Agent

Date

APPENDIX IV

ROUTINE MAINTENANCE

Appendix IV has been included for the information and benefit to the building owner, business owner and CAB reviewer. It can be used as a reference for keeping a project simple, preservation-sensitive and on track.

IV.1) Eight Steps to Complete a Preservation Project

The following is an outline of an accepted approach to planning and implementing preservation projects. Property owners should review these points carefully and consider their importance. The first three steps of the planning phase should be completed prior to the submission of a Certificate of Appropriateness application. These steps are explained in recommended order:

STEP 1

Inspect and Document the Property and Make a Wish List

A thorough inspection of the structure or site will allow for an understanding of specific problems that may exist, as well as special conditions and features that need to be considered. This inspection should also take into account the character of the surrounding area (area of influence), with special attention given to how the property in question relates to nearby buildings and sites. Develop a wish list of what needs to be done and what improvements and/or changes are desirable, but not necessary, to the physical soundness of a property.

Before any work is undertaken, existing conditions of the historic property should be documented through photographs. This is especially true when tax credits are being sought for the rehabilitation of an income-producing property. Property owners should consult with the State Historic Preservation Office if they anticipate applying for federal tax credits (see Appendix B: Financial Incentives for Historic Preservation Projects for more information).



Conway historic district marker, 2009

STEP 2

Define the Project and Develop a Preliminary Concept

At this stage the property owner must determine the preservation method (stabilization, rehabilitation, restoration, or reconstruction) and extent of the project to be undertaken. It is advisable to consult with an architect, landscape architect, interior designer or preservation planner for assistance in defining the basic components of the project. At this stage, the preliminary concept should be presented to the Historic Preservation Commission for initial comments.

STEP 3

Refine Preliminary Concept and Develop a Master Plan

This is the final step of the planning process, the end result of which is often called a Master Plan. The Master Plan should outline the principal goals of the project and the efforts needed to complete Steps 4 through 8.

Apply for a Certificate of Appropriateness.

STEP 4

Stabilize the Building

Before any new work is undertaken, the property must be in a stable condition with all deterioration halted. An example would be the repair of a leaking roof so that further moisture will not enter the structure after new work has been completed.

APPENDIX IV-1 (Continued)



Main Street Conway, 2009



New Commercial Addition - Conway, 2010



New Riverfront Construction - Conway, 2010



Historic residence in Conway, 2010

General images of Conway's multiple Historic Design Review Districts.

(Continued from previous page)

STEP 5

Carry Out Structural Repairs

Once deterioration has been halted, any structural damage must be corrected. This type of work needs to be completed as one step rather than in phases. If the approved project involves an addition to the building, it should be made only after all structural repair work has been completed.

STEP 6

Carry Out Infrastructure Repairs

Repairs and improvements to mechanical systems (i.e., cooling and heating systems, electrical systems and plumbing) are essential to achieving the highest degree of comfort and economy in any building. Attend to this type of work fairly early in the overall project rather than delaying or even neglecting to complete it. Infrastructure improvements can be costly, which is yet another reason for placing this work early in the project schedule.

STEP 7

Carry Out Energy Conservation Improvements

Most steps to improve energy efficiency are generally quite straightforward and sometimes surprisingly inexpensive. Therefore, this type of work can usually be put off until more complicated and expensive tasks have been completed.

STEP 8

Carry Out Cosmetic Work

Finishing work, such as exterior painting, minor siding repairs and porch reconstruction, should be the final stage of a preservation or rehabilitation project. This is the work that will generally create the greatest visual impact, and it is essential that all preliminary work (stabilization, structural repairs and infrastructure improvements) be completed beforehand so that nothing will have to be done twice.

IV.2.) National Park Service Preservation Briefs

For over 25 years, the National Park Service Technical Preservation Services division has helped home owners, preservation professionals, organizations, and government agencies by publishing easy-to-read guidance on preserving, rehabilitating and restoring historic buildings.

Below is a list of the 46 Preservation Briefs that are available online at <http://www.cr.nps.gov/>. These can also be purchased in hard copy from the U.S. Government Bookstore at <http://bookstore.gpo.gov/> or by calling 866.512.1800.

- | | |
|---|--|
| 01: <i>Assessing Cleaning and Water-Repellent Treatments for Historic Masonry Buildings</i> | 23: <i>Preserving Historic Ornamental Plaster</i> |
| 02: <i>Repointing Mortar Joints in Historic Masonry Buildings</i> | 24: <i>Heating, Ventilating, and Cooling Historic Buildings: Problems and Recommended Approaches</i> |
| 03: <i>Conserving Energy in Historic Buildings</i> | 25: <i>The Preservation of Historic Signs</i> |
| 04: <i>Roofing for Historic Buildings</i> | 26: <i>The Preservation and Repair of Historic Log Buildings</i> |
| 05: <i>The Preservation of Historic Adobe Buildings</i> | 27: <i>The Maintenance and Repair of Architectural Cast Iron</i> |
| 06: <i>Dangers of Abrasive Cleaning to Historic Buildings</i> | 28: <i>Painting Historic Interiors</i> |
| 07: <i>The Preservation of Historic Glazed Architectural Terra-cotta</i> | 29: <i>The Repair, Replacement, and Maintenance of Historic Slate Roofs</i> |
| 08: <i>Aluminum and Vinyl Siding on Historic Buildings: The Appropriateness of Substitute Materials for Resurfacing Historic Wood Frame Buildings</i> | 30: <i>The Preservation and Repair of Historic Clay Tile Roofs</i> |
| 09: <i>The Repair of Historic Wooden Windows</i> | 31: <i>Mothballing Historic Buildings</i> |
| 10: <i>Exterior Paint Problems on Historic Woodwork</i> | 32: <i>Making Historic Properties Accessible</i> |
| 11: <i>Rehabilitating Historic Storefronts</i> | 33: <i>The Preservation and Repair of Historic Stained and Leaded Glass</i> |
| 12: <i>Preservation of Historic Pigmented Structural Glass (Vitrolite and Carrara Glass)</i> | 34: <i>Applied Decoration for Historic Interiors: Preserving Historic Composition Ornament</i> |
| 13: <i>The Repair and Thermal Upgrading of Historic Steel Windows</i> | 35: <i>Understanding Old Buildings: The Process of Architectural Investigation</i> |
| 14: <i>New Exterior Additions to Historic Buildings: Preservation Concerns</i> | 36: <i>Protecting Cultural Landscapes: Planning, Treatment and Management of Historic Landscapes</i> |
| 15: <i>Preservation of Historic Concrete: Problems and General Approaches</i> | 37: <i>Appropriate Methods of Reducing Lead-Paint Hazards in Historic Housing</i> |
| 16: <i>The Use of Substitute Materials on Historic Building Exteriors</i> | 38: <i>Removing Graffiti from Historic Masonry</i> |
| 17: <i>Architectural Character - Identifying the Visual Aspects of Historic Buildings as an Aid to Preserving Their Character</i> | 39: <i>Holding the Line: Controlling Unwanted Moisture in Historic Buildings</i> |
| 18: <i>Rehabilitating Interiors in Historic Buildings - Identifying Character-Defining Elements</i> | 40: <i>Preserving Historic Ceramic Tile Floors</i> |
| 19: <i>The Repair and Replacement of Historic Wooden Shingle Roofs</i> | 41: <i>The Seismic Retrofit of Historic Buildings: Keeping Preservation in the Forefront</i> |
| 20: <i>The Preservation of Historic Barns</i> | 42: <i>The Maintenance, Repair and Replacement of Historic Cast Stone</i> |
| 21: <i>Repairing Historic Flat Plaster - Walls and Ceilings</i> | 43: <i>The Preparation and Use of Historic Structure Reports</i> |
| 22: <i>The Preservation and Repair of Historic Stucco</i> | 44: <i>The Use of Awnings on Historic Buildings: Repair, Replacement and New Design</i> |

IV.3.) Getting Energy Efficiency from Older Buildings

This article is excerpted from a presentation given at the *Tax Incentive Workshop for Energy Efficient Buildings* sponsored by the Chatham County-Savannah Metropolitan Planning Commission on August 23, 2006.

By Bill Hover, Architectural Reviewer
Georgia Department of Natural Resources – Historic Preservation Division.

Introduction

This article is intended to provide the reader with some basic information about energy efficiency and historic buildings so that logical and smart choices can be made regarding decisions that combine the two.

Prefatory to considering energy efficiency and historic buildings, bear in mind the following:

- 1. Where does energy efficiency rank for you as a priority in building use and function?*
- 2. Do you understand how your home or building deals with energy?*
- 3. Do you keep track of your home or building energy usage and costs?*
- 4. Have you have had an energy audit?*
- 5. What can you afford to spend to have an energy efficient home?*
- 6. Do you think you need new windows?*

Establishing the Paradigm

To start our discussion of energy efficiency, we need to establish, define, and understand what is actually being dealt with.

The basic concept here, then, is that buildings are used to shelter us from “the elements,” mainly rain, temperature, and other manifestations of the weather. Our expectations are that they provide comfortable warmth in winter, comfortable coolness in summer, and both at a reasonable cost.

To this end, our shelters have evolved from simple use of natural sheltering features (such as caves), to minimal built comfort (like log cabins), to moderate built comfort in sync with the local environment (such as houses and buildings in the south with high ceilings, sleeping porches, and tall windows strategically

located to take advantage of cross-breezes), to buildings designed for excellent comfort in all seasons using advanced climate control that is a fundamental intent of most new construction.

While this seems to put energy efficiency into a simple enough context, everyone has probably had some experience with the complications of achieving such environmental comfort.

So let’s look at some of the complications.

Building Systems and Definitions

As we have made advances in controlling our interior environment to counter the exterior environment, our relatively simple systems have become complex ones. Yet we are still dealing with two principal challenges.

First, we have exterior environmental encroachment, which involves Nature’s need to equalize everything, or to put it another way “Nature abhors a vacuum.” This balancing act is a dynamic one, one that is constant and continuous. We recognize its effects, cold air rushing in when the door’s opened in the winter, water evaporation on a hot day, but maybe do not exactly understand why it happens and how it relates to energy efficiency.

Second are the inherent weaknesses in our building systems. These boil down to the need to have openings in our buildings and, also, by the very nature of the way they are put together, creation of air leakage points.

Now, in this context, building systems are:

- The Building Structure: roof, walls, windows and doors – this is considered the building “envelope”*
- The Mechanical System: consisting of furnace, air conditioner, duct work, and*
- Energy Users (which are in addition to the mechanical system): including water heater, dish washer, clothes washer, dryer, refrigerator, lighting, and other appliances.*

(Continued on next page.)

APPENDIX IV.3. (Continued)

Before we look at how we meet these challenges, a review of some terms that crop up in specifications, advertising, and other discussions of energy efficiency is appropriate, like:

- *R-Values and U-values.* These are scientific calculations that measure thermal resistance (*R*) and thermal conductance (*U*), or in simpler terms, how slowly or quickly heat flows through a material. These values are related, in that they are the inverse of each other ($U=1/R$). They show up on labels for insulation and windows, but the important things to remember are the larger the *R*-Value or the lower the *U*-value the better the insulating capability.

- *Conduction, convection, and radiation.* These are the different ways of heat (energy) transference. Conduction is through solid objects, convection is by air movement, and radiation is heat transfer from a surface to the surrounding air without a transfer medium.

Notice that these terms closely parallel the two challenges mentioned. Other terms that can appear include:

- *Vapor Diffusion.* This is the movement of moisture in the vapor state through a material because of vapor pressure and temperature differences. Moisture moves from areas of greater to lesser concentration and from warm to cool sides of materials. The measurement of moisture movement is by units of permeability, also known as “perms.” Any material with a perm rating of less than 1.0 is a Vapor Diffusion Retarder (aka Vapor Barriers).

- *Climate Zones.* These have been established for the United States by the National Oceanic and Atmospheric Administration (NOAA) and are regions with relatively homogenous climates based on 30-year averages for heating degree-days (HDD) and cooling degree-days (CDD) calculations. Georgia falls in Climate Zones 4 (northern) and 5 (southern).

- *Insulation Zones.* The U.S. is also divided into Insulation Zones, which, in Georgia at least, roughly parallel the Climate Zones. Insulation Zones are used for design purposes to determine recommended insulation levels. Georgia falls for the most part in Insulation Zones 4 (southern) and 5 (northern).

Note that climate zones and insulation zones provide important basic guidance for design purposes and characterize our environmental adversary. However, be aware that the various places you find this information use the data to define the zones somewhat differently. So depending on where you look, be it the internet, code books, or other sources, the maps and zone designations are probably going to vary. Nonetheless, the basic information is pretty consistent.

With the help of these definitions, we need to bring our discussion into some sort

of understandable perspective.

Approaches to Energy Efficiency Improvements

On one hand we have a building, its systems, and the desire to be energy efficient and comfortable at a reasonable cost. On the other hand we have Mother Nature knocking at the door. What to do, what to do?

The first thing to do is know what you’re working with and where you want to get. In other words, you need to understand your local climate, its recommended design efficiencies, and make an assessment of your building systems, which also includes understanding your individual energy costs.

Understanding your local climate and design efficiencies is relatively easy - - you look at maps and tables. Probably the most useful are the Insulation Zone Map and tables of Insulation Groups, which are available on the U.S. Department of Energy website.

The tables provide recommended levels of insulation for various parts of your house. For instance, southern Georgia falls in Insulation Zone 4. If you have gas heat, this puts you in Insulation Group E-3. The recommended amounts of insulation for this group include:

- R-38 for Attics, which equals about 13”
- R-11 for floors over unconditioned space and for walls, which equals about 3 1/2”

An alternate source for similar information is the International Energy Conservation Code (be aware it will look different than the DOE maps and tables). These numbers give you a baseline for comparison when you assess your building systems. But besides looking at how much or little insulation you have, you need to look at and evaluate other things, too. In no particular order, you should inspect the building envelope for leakage points, which includes around windows, doors, fireplaces, and pipe and wire penetrations; check floors, walls, and attics for insulation levels; check your furnace and air-conditioning unit to determine if they are approaching an age where they might need replacement; check your duct work for joint seals and insulation; finally, check your major appliances, including water heater, to determine if they are getting to the point of replacement.

Concurrent with the building systems assessment, you also need to look at past energy costs and usage, since without this information, you really can’t quantify any improvements. Of these two numbers, the one for usage will likely be more useful as an indicator of improved efficiency.

(Continued on next page.)

APPENDIX IV.3. (Continued)

With this information in hand, it's time to look at a couple of other government provided charts. These charts identify how we typically use and lose energy. Combined, they tell us where money is best spent to make improvements. Also factored into these prioritization decisions should be the ease with which something can be accomplished.

So how would this work? Maybe something like this (indulgence is requested for taking and manipulating numbers out of context):

If the building systems assessment reveals that wall penetrations aren't sealed, openings aren't caulked and weather-sealed (windows will be addressed a little later), and duct work isn't properly sealed and insulated, then it makes good sense to take care of these things first. Air leakage from these areas accounts for almost half of the infiltration total and the single worst culprit is duct work, accounting for 15%. Sealing and insulating duct work, caulking plumbing and other penetrations could eliminate more than a quarter of the air leakage. And, relatively speaking, doing so is easy and inexpensive, as typically everything is readily accessible, and the quantity of the materials small and reasonable cheap.

To get a sense of what this means relative to energy efficiency, if, using the energy use chart, 34% of energy used is for space heating and 11% for cooling, and you assume the reason you're using that energy is, in great part, to replace conditioned air lost due to leakage, then eliminating more than 25% of the leaks should reduce total energy usage by about 12% (.34+.11=.45x.28=.126).

While more expensive because of the amount of material you'd need, adding insulation to recommended levels is also cost effective, especially if added to attic spaces and floors over unconditioned spaces. In such a scenario, since the chart combines floors, walls, and ceiling leakage (31%), let's say floors and ceiling account for about half of that – 16% – doing so should reduce energy usage another 7% (.45x.16=.072).

In this hypothetical example, over 19% energy savings could be achieved by doing things relatively easy that wouldn't have a major disruption factor on building use. Obviously, real- world results will vary.

Now consider some big-ticket items. If the furnace and air-conditioning unit are old and need to be replaced, doing so with ones, for instance, 15% more efficient, should translate into energy savings of about another 7% (.45x.15=.0675). Applying the same 15% more efficient figure to a new refrigerator gains you 1% and to a new water heater about 2%.

Again, while these numbers are hypothetical, there is a recognizable trend here. That is, doing some less expensive, relatively easy, and low physical impact work

results in greater energy savings, while more expensive equipment replacement work, while making sense if replacement is necessary, actually has a lower energy savings return of investment or one that takes longer to recoup expenditures.

Which brings us to windows.

Somehow old windows have become the poster-child for energy inefficiency, while new windows are touted as the miracle cure - - "cut your energy bills up to 25%!" However, such numbers don't appear to stand up under closer examination. If, using DOE figures, windows account for 10% of energy loss (air leakage), stopping all of that loss only calculates into energy savings of just under 5% (.45x.10=.045). Additionally, this best-case scenario is unlikely in that a typical single-glazed wood window should have a U-value of about .98, which converting to R-value is about 1. A comparable double-glazed window with a low-e treatment has a U-value of about .34 or R-3. Logic would indicate the values available aren't great enough to achieve such a remarkable improvement in overall energy usage.

The point here is that windows are, by their very nature, not very energy efficient. However, they also provide a multitude of functions; among them are light, ventilation (sometimes) and stylistic character. Light and ventilation come at a cost to energy efficiency that we all seem willing to pay. And, from casual observation and judging from the selection of windows used in new construction, it appears that the costs of style are readily accepted, too.

From a preservationist perspective, old windows are very significant to the stylistic character of old buildings; in fact, they go further, because they also help define their physical historic character. As such, retaining old windows as part of a rehabilitation renovation or maintenance project really is a reasonable and desirable expectation. And, old windows don't need to be replaced for the sake of energy efficiency. Some independent studies indicate that adding a storm window to single-glazed windows will provide similar efficiencies as new double-glazed windows.

But this isn't to say you should keep the old windows in their current condition, which in many cases probably is pretty sad. It's kind of ironic that old windows have proven durability because they've withstood neglect, little or no maintenance for years and years, yet can often be repaired to function as they did originally and continue to last indefinitely, with a little care.

The reasons for this are that the material these windows are made from generally is of a higher quality than what is readily available and typically used today, and their assembly techniques make them quite repairable. Of course, that doesn't
 (Continued on next page.)

APPENDIX IV.3. (Continued)

mean that working on old windows is necessarily cheap, but, then again, neither are replacement windows.

But you might be thinking about maintenance and its associated costs. The answer to that is twofold.

First, maintenance is a good thing. Stuff lasts longer if you take care of it. And, if you are doing regular maintenance, you get to know your building and systems pretty well and have a greater chance of catching problems when they're small and easily taken care of. Windows that are candidates for replacement probably got that way because they were neglected. If they had been taken care of regularly, their maintenance costs should have been relatively low. The alternative to maintenance is a big window project, either repair or replacement - - both expensive. And, actually, what are your choices? Repair a window that may last as long or longer than it already has (60-80-100 years?) or put new ones in that tout low or no maintenance and a warranty that ends at 20-years.

Second, if something isn't designed for maintenance, by default it's designed for replacement. Which in the long run costs more?

So, while it makes sense to replace a window that has deteriorated to the point that it can't be repaired, replacing repairable windows doesn't appear quite as logical when you factor in these considerations.

While windows have been the main point of this retention versus replacement discussion, the same basic concepts apply to other historic features as well. Some energy efficiency improvement projects can be done with little or no impact on historic features and materials, like adding attic insulation; others could constitute a historically detrimental impact, like removing plaster to insulate walls.

Other cautionary notes relative to energy efficiency improvements.

In historic buildings energy efficiency improvements could also have unintended consequences, which for the most part generally involve moisture-related problems, including mold, rot, condensation, and peeling paint. When sealing and insulating and otherwise making a building snug and tight, you might also be creating situations where moisture is being trapped and will lead to these problems.

How could this happen?

One circumstance could be installing a "vapor barrier" incorrectly. The general rule of thumb is to put a Vapor Diffusion Retarder on the warm side of the building envelope. But, you might be thinking, "the warm side varies, in winter it's the inside, in summer, it's the outside." Well, what's really recommended is based on

what Climate Zone you're in and more specifically its number of Heating Degree Days. For Georgia, generally, in the northern half of the state, the Vapor Diffusion Retarder should be put on the interior side, while in the southern portion of the state one shouldn't be used.

Another situation could be the inadvertent use of a paint, which because of its perm rating, acts as a Vapor Diffusion Retarder. If you're having paint peeling problems, that could be a reason why your paint is not sticking.

Other moisture problems might have to be dealt with by adding exhaust vents in bathrooms and kitchens and/or by installing a dehumidifier.

Conclusion

Improving the energy efficiency of historic buildings can be a beneficial objective. Doing so makes the buildings more desirable and agreeable as places in which to live and work, allowing for their continued use, which also helps stabilize communities and neighborhoods. Often these improvements can be accomplished economically and with minimal physical impact on the historic fabric of the buildings. However, the means by which the improvements are made and the level of improvement expected should be carefully considered so that the historic character of the buildings is not compromised and so that money will be spent for those improvements which will provide the best results.

To plan an energy efficiency improvement project, remember to:

- *Recognize your building as an assembly of systems – framing, including wall/ceiling/roof finishes; mechanical system, including furnace, A/C, and duct work; and energy users, including water heater, appliances, and lighting.*
- *Identify weaknesses in the systems and where they might be failing or need improvement. Understand that changes in one system may impact the others, e.g., sealing the house up too tight may result in conditions where existing ventilation and humidity control are no longer adequate, resulting in mold growth and other moisture-related problems.*
- *Fix or improve the easy and less expensive stuff first.*
- *Avoid treatments that require wholesale removal or loss of historic material or finishes.*

A good source for energy efficiency guidance can be found at: www.eere.energy.gov/buildings/info

APPENDIX V

FINANCIAL INCENTIVES FOR PRESERVATION WORK

V.1.) Federal Historic Rehabilitation Income Tax Credit

The RITC program provides an opportunity to owners of certified historic structures, who undertake a certified rehabilitation, a federal income tax credit equal to 20% of the qualified rehabilitation expenses. Only properties utilized for income-producing purposes can take advantage of this credit. In general, each dollar of tax credit earned reduces the amount of federal income taxes owed by one dollar.

To be eligible for the 20% tax credit:

- The building must be listed, or eligible for listing, in the National Register of Historic Places, individually or as a “contributing building” within a historic district.
- The project must meet the “substantial rehabilitation test.” (This is the cost of rehabilitation must be greater than either the adjusted basis of the property (the purchase price minus land value plus the value of improvements made, minus depreciation already taken) or \$5,000, whichever is greater.) Also, projects must be finished within two years, unless stated as phased.
- Following rehab, the building must be used as an income-producing purpose (offices, stores, rental housing, etc.) for at least 5 years
- The rehabilitation work itself must be done according to The Secretary of the Interior’s Standards for Rehabilitation; these are common-sense guidelines for appropriate and sensitive rehabilitation (see pg. A.11 in these guidelines)

All rehabilitation tax credit projects must be reviewed by the State Historic Preservation Office located at the South Carolina Department of Archives and History (SCDAH) and then certified by the National Park Service (NPS), who administers the overall program. All applications MUST begin with the SCDAH.

A property owner interested in participating in the RITC program must submit the Historic Preservation Certification Application and supporting documentation to the SCDAH for review and comment. After SCDAH staff reviews the work, the project is forwarded to NPS for final certification.

The application has three parts: Part 1 requests documentation that the building is a historic structure, listed or eligible for listing in the National Register of Historic Places. Part 2 requests a detailed description of the rehabilitation work supplemented that REQUIRES “before” rehab photographs and proposed floor plans. The Part 2 should be submitted to SCDAH before work begins to ensure compliance with the Standards. Part 3 is the Request for Certification of Completed Work. This application is submitted after the rehabilitation is complete and requests photo-documentation of the rehabilitation in compliance with the Standards for Rehabilitation.

South Carolina Dept. of Archives and History encourages early communication with their office. For more information: www.scdah.sc.gov click on “Historic Preservation,” “Grants & Tax Incentives” or contact a SCDAH preservation specialist at 803-896-6183.

There is also a 10% federal income tax credit available to property owners who rehabilitate non-historic buildings built before 1936.

To be eligible for the 10% tax credit:

- The building must be built before 1936 and be non-historic.
- A building must meet the physical wall retention test. At least 50% of the building’s walls existing before the rehab must remain as external walls, at least 75 % of the external walls must remain in place as either external or internal walls, and 75% of the internal structure must remain in place.
- The project must meet the “substantial rehabilitation test.” Generally, projects must be finished within two years.
- The building must be used for non-residential, income-producing purposes for at least five years after the rehabilitation.

Rehabilitation work under the 10% tax credit program must be applied for through the SCDAH, however review takes in consideration for the “non-historic” status. If the above criteria are fulfilled, then the 10% rehabilitation tax credit can be claimed as an investment credit on an owner’s federal income tax return.

Charitable Contribution Deduction

The charitable contribution deduction is a donation of the historic value of a structure and is available to owners of residential and income-producing properties. The deduction is taken in the form of a conservation easement and enables the owner of a “certified historic structure” to receive a one-time tax deduction. A conservation easement ensures the preservation of a building’s facade by restricting the right to alter its appearance. Qualified professionals should be consulted on the matters of easement valuations and the tax consequences of their donation.

For more information on Federal Tax Incentive Programs see a professional tax specialist, qualified preservation consultant or go to:

- The National Park Service: www.nps.gov/history/hps/tps/tax/
- The US Internal Revenue Service, Real Estate Tax Tips: www.irs.gov/businesses/small/industries/article/0,,id=97599,00.html
- **All Applications & Information from State Historic Preservation Office:** www.scdah.sc.gov/grants/overview/

APPENDIX V: FINANCIAL INCENTIVES (Continued)

Through legislative acts, the State of South Carolina (at the time of printing these guidelines) offers two levels of State income or license tax credits for qualified rehabilitation work on historic properties. **Owners of historic buildings in South Carolina who meet the requirements for the 20% Federal Historic Rehabilitation Tax Credit (see Appendix V, V.1) may also qualify for state income tax credits.**

Taxpayers do not have to go through a separate State Historic Preservation Office (SHPO) application process. Successfully completing the federal application process qualifies them for the state credit.

V.2.) South Carolina State Historic Rehab Tax Incentives

10% State Historic Rehabilitation Tax Credit

Incentive: State income or license tax credit equal to 10% of rehabilitation costs. In general, each dollar of tax credit earned reduces the amount of state income or license taxes owed by one dollar.

Eligible buildings: Those buildings that meet the requirements for the 20% Federal Historic Rehabilitation Tax Credit are automatically eligible for the added state program.

Authorizing legislation: South Carolina Rehabilitation Incentives Act (Section 12-6-3535, SC Code of Laws, 1976, as amended).

(Information obtained at www.scdah.sc.gov/grants/overview/ as of Jan. 2011)

25% State Historic Rehabilitation Tax Credit

Incentive: State income tax credit equal to 25% of allowable rehabilitation expenses. In general, each dollar of tax credit earned reduces the amount of state income taxes owed by one dollar. (Allowable expenses include exterior rehabilitation work; repair of historic structural systems, improving energy efficiency; repairs and installation of heating, air-conditioning, plumbing, and electrical systems; restoration of historic plaster; and architectural and engineering fees.)

Eligible buildings: Buildings must be listed in the National Register of Historic Places, individually eligible for the National Register, contribute to a National Register historic district, or be a historic outbuilding associated with a residence that is eligible for the program.

Eligible use: Owner-occupied residence (not used in a trade or business, held for the production of income, or held for sale or disposition in the ordinary course of the tax payer's trade or business).

Expenditure requirements: \$15,000 of allowable rehabilitation expenses within 36 months. (See definition of allowable rehabilitation expenses above.)

Review of work: The State Historic Preservation Office (SHPO) must review and approve plans before work begins. The SHPO must certify that the rehabilitation meets the Secretary of the Interior's Standards for Rehabilitation.

Authorizing legislation: South Carolina Rehabilitation Incentives Act (Section 12-6-3535, SC Code of Laws, 1976, as amended).

APPENDIX V: FINANCIAL INCENTIVES (Continued)

The Horry County Board of Architectural Review was first formulated in 1987 and has continued to operate then under the **Horry County Code of Laws**.

There are many benefits to historic preservation. Below are listed some of the benefits. We would encourage you to designate your property as a local historic property or as a part of a historic district. This would enable you to gain access to the potential benefits.

Owners of historic buildings in South Carolina who meet the requirements for the 20% Federal Historic Rehabilitation Tax Credit (see Appendix V, V.1) may also qualify for Horry County income tax credits.

Source: Horry County Board of Architectural Review website www.horrycounty.org/boards/bar/brochures.asp
(Horry County BAR also produces a set of Historical Brochures)

V.3.) Horry County Tax Incentive

For the certified rehabilitation of qualified owner-occupied residences:

Incentive: Horry County tax incentive freezes property taxes for 10 years at value prior to improvement value.

Eligible buildings: Owner-occupied residences.

Eligible use: Not specified.

Expenditure requirements: Not specified.

Review of Work: Please contact the Horry County Planning & Zoning Dept in the County Government & Justice Center located at 1301 Second Ave., Conway, SC 29526, or call 843-915-6340. Program may be used in addition to federal and state preservation tax incentives so early coordination is encouraged.

(Information obtained at:
www.horrycounty.org/depts/econdev/PlanningZoning/index.asp as of Mar. 2011)

Horry County Historic Preservation Facts: **

1. Historic Preservation Activities Create Jobs - Preservation activities directly create 400 jobs and another 369 indirectly on an annual basis as a result of historic preservation construction activity.

2. Historic Preservation Increases Property Values - Properties located within locally designated historic districts are worth more, appreciate faster, and retain more of their value.

3. Historic Preservation is the Vehicle for Heritage Tourism - Heritage Tourism results in \$325.6 million annually in South Carolina -resulting in the creation of 9,097 jobs and another 2,300 jobs created indirectly.

4. Historic Preservation has spurred Downtown Revitalization - Downtown revitalization, from 1984-2000, has resulted in a total investment of \$375 million. Results - 1,597 buildings rehabilitated with 6,153 jobs and 1,752 businesses created.

5. Historic Preservation is an economic force in South Carolina - Historic preservation activities have added \$73.5 million in spending and \$22 million in increased labor earnings.

**** SC Department of Archives and History "Smiling Faces Historic Places Economic Benefits of Historic Preservation in SC Economic Report**

Historic District Benefits in Horry County

Local districts protect the investments of owners and residents. Buyers know that the aspects that make a particular area attractive will be protected over a period of time. Real estate agents in many cities use historic district status as a marketing tool to sell properties.

Local districts encourage better design. It has been shown through comparative studies that there is a greater sense of relatedness, more innovative use of materials, and greater public appeal within historic districts than in areas without historic designations. Local districts help the environment. Historic district revitalization can, and should, be part of a comprehensive environmental policy.

The educational benefits of creating local districts are the same as those derived from any historic preservation effort. Districts help explain the development of a place, the source of inspiration, and technological advances. They are a record of our communities and us.

A local district can result in a positive economic impact from tourism. A historic district that is aesthetically cohesive and well promoted can be a community's most important attraction. The retention of historic areas as a way to attract tourist dollars makes good economic sense.

The protection of local historic districts can enhance business recruitment potential. Companies continually re-locate to communities that offer their workers a higher quality of life, which is greatly enhanced by successful local preservation programs and stable historic districts.

Local districts provide social and psychological benefits. A sense of empowerment and confidence develops when community decisions are made through a structured participatory process rather than behind closed doors or without public comment.

SUMMARY OF ADDITIONAL BENEFITS:

1. Local properties can be protected by the implementation of specifically tailored "Design Review Guidelines" geared toward a particular historic district or property with the assistance of citizens and property owners.
2. Property values may potentially increase and stabilize, thus increasing resale and market values.
3. Potential of decreased taxes when qualifying for tax incentives: Federal, State Income taxes and Local property taxes.
4. Value to local history & school curriculums with programs such as the "Teaching with Historic Places" program - introduces our children to local history as related to state and national history.
5. Increased connections to our cultural and historical heritage.
6. Increased dialogue among children, parents and grandparents, regarding our ancestors and history.
7. Value of preserving a building, district, neighborhood, farmstead or homestead, "A Sense of Place".
8. Increased quality and value to our local economy and commerce, from design to construction, real estate, and heritage and cultural tourism attractions. According to SC Department of Archives and History Staff, Cultural and Heritage Tourism is the No 1 tourist attraction in South Carolina for nine months and the No 2 attraction for the remaining three months, every year.
9. Potential cost savings to renovate rather than to build new (based on statistical records of other historical properties in South Carolina).
10. Potential for obtaining grants for qualifying properties.
11. Recognition by County, State and Federal Government via publications, brochures, awards programs, marker programs, and individual property Register of Historic Places bronze plaques.
12. Assistance from the Horry County Board of Architectural Review to property owners regarding Historic Preservation issues.

HCBAR estimates that there are only about 100 properties (.01% or 100 out of 100,000) in the non-incorporated areas of Horry County that currently qualify for local or National Historic Designation, so your property is a treasure we hope can be preserved.

(Source: Horry County Board of Architectural Review)

APPENDIX V: FINANCIAL INCENTIVES (Continued)

V.4.) Conway Property Tax Abatement & Incentives

**Local Property Tax Abatement
(Also for Voluntary CAB Review Program)**

Incentive: The property is assessed on the pre-rehabilitation fair market value for the length of the special assessment (up to 20 years, length set by the local government).

NOTE: City of Conway has set the Abatement Period to: 15 years.

Eligible buildings: A building must be designated historic by the local government and the local government must have adopted an ordinance to implement the property tax abatement program. Buildings designated historic by the local government can include buildings listed individually in the National Register of Historic Places or contributing to a National Register historic district, or buildings that meet the local government’s criteria for historic designation.

Eligible use: Owner-occupied residence or income-producing building.

Expenditure requirements: Expenditures for rehabilitation must exceed a minimum expenditure set by the local government. **In Conway, locally, this is has been set at rehabilitation work exceeding 25% of the fair market value* for owner-occupied buildings, or exceeding 25% of the fair market value* for income-producing property.**

Review of work: A reviewing authority must approve that the proposed and completed rehabilitation work is appropriate for the historic building and the historic district in which it is located. The reviewing authority is the local board of architectural review (the Conway Community Appearance Board, as designated in Article 14 of the *Conway Unified Development Ordinance*), or can be done through the State Historic Preservation Office (SHPO).

Authorizing legislation: Sections 4-9-195 and 5-21-140, SC Code of Laws, 1976, as amended (often referred to as the “Bailey Bill”).

(Contact the Conway Planning Department for the applicable City ordinance and for details about the local Historic Tax incentive programs for contributing historic or if you would like to submit your property for voluntary review.)

Tax Incentives for Rehabilitating Textile Mill Buildings (statewide)

Incentive: A credit against local property taxes equal to 25% of rehabilitation expenses or a state income tax credit equal to 25% of rehabilitation expenses.

Eligible buildings: Abandoned buildings formerly used as textile manufacturing facilities or for ancillary uses.

Eligible use: Not specified.

Expenditure requirements: Not specified.

Review of Work: The law does not require review of the project work. However, if a developer or owner is also pursuing the 20% Federal Historic Rehabilitation Tax Credit and the 10% State Historic Rehabilitation Tax Credit for the project, the project must follow the review and approval process required for these credits.

Authorizing legislation: South Carolina Textiles Communities Revitalization Act (Section 6-32-10, SC Code of Laws, 1976, as amended)

(* “Fair Market Value” in this case means the appraised value as certified to the Community Appearance Board by a real estate appraiser licensed by the State of South Carolina, the sales price as delineated in a bona fide contract of sale within six (6) months of the time it is submitted, or the most recent fair market value published by the Horry County Tax Assessor.)

(Information obtained at www.scdah.sc.gov/grants/overview/ as of Jan. 2011)

APPENDIX VI

HINTS FOR A SUCCESSFUL HISTORIC DISTRICT BUSINESS

Some practices are not reviewed. Here are a few simple hints to running a successful, courteous business in the Conway Downtown Commercial Historic District and where to find more about them in the guidelines:

First impressions are lasting impressions. Curb appeal is an investment that offers positive perceived value. Make your entrances attractive and your storefront clean, uncluttered, well maintained and your display windows appealing and inviting. Keep your display lights on, ESPECIALLY during the day when glare is high and contrast from bright sun to shaded, dark displays can give the immediate impression that you are closed!

Restrooms are a necessity and a convenience. Currently Conway does not have a public restroom facility for the downtown and all businesses may be able to help with this. Take the "toilets attract" approach if it is possible. Allow customers to utilize your facilities and make them welcoming. Avoid "no restrooms" or "customers only" signs even if they are inaccessible. The restroom gets your customer into the business -- all the way to the back!

Keep signs simple, clear, decorative, and professional. Do not include much verbiage (less than 6 words). Signage doesn't have to be the name of the company, it can be what you sell! Blade signs (perpendicular to the street) are allowed and provide motorists and pedestrians good visibility. (Refer to the Conway sign ordinance.)

Parking --- Allow your customers to use the parking in front of your business and have all your employees park out of the retail areas.

Remember that "critical mass" is a rule of convenience. Pedestrian-friendly walkways, where visitors can walk from store to store to restaurant to business, provide for happy shoppers and diners who will stay longer and spend more money!

Quick Reference Guide to These Guidelines:

First Impressions:



Character: pg. A-6



Storefronts: pg. B-9



Displays: pg. B-13

Keep Signs Simple:



Primary Signs: pg. C-8



Secondary Signs: pg. C-10

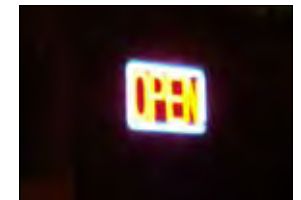

Subordinate Signs: pg. C-11

Historic Environment and Commercial Conveniences:



Environment: pg. A-8



Awnings: pg. B-22



Patios-Dining: pg. B-26

APPENDIX VII

ADDITIONAL RESOURCES FOR ASSISTANCE

There are hundreds of other sources, organizations (national and state-wide). However just a few websites to contact for additional information on historic preservation, technology and good planning principles that you may wish to begin your search at, but not limit yourself to, are:

How to preserve and revitalize historic downtowns and main streets:

National Trust Main Street Center

1785 Massachusetts Avenue, NW.

Washington, DC 20036

(202) 588-6219

www.mainstreet.org

Local: www.conwaymainstreet.com or (843) 248-6260

Rehabilitation tax incentives, grants, historic resource surveys, and the National and South Carolina Register of Historic Places programs:

State Historic Preservation Office (SHPO)

South Carolina Dept. of Archives and History

8301 Parklane Road

Columbia, SC 29223

(803) 896-6171

www.scdah.sc.gov

Best practices and model preservation policies, Public Policy Weekly Bulletin:

National Trust for Historic Preservation

1785 Massachusetts Ave, NW

Washington, DC 20036-2117

(202) 588-6000

www.nationaltrust.org

The Secretary of the Interior's Standards for Rehabilitation and Guidelines for Rehabilitating Historic Buildings:

Heritage Preservation Services

National Park Service

1849 C Street, NW (2255)

Washington, DC 20240

www.nps.gov/history/hps/tps/standguide/index.htm

Historic Districts Are Good for Your Pocketbook: The Impact of Local Historic Districts on House Prices in South Carolina

Research Report by SC State Historic Preservation Office

(Downloadable PDF Copy at: www.scdah.sc.gov)

Smiling Faces Historic Places: The Economic Benefits of Historic Preservation in South Carolina

Research Report by SC State Historic Preservation Office

(Downloadable PDF Copy at: www.scdah.sc.gov)

Preserving Our Past to Build a Healthy Future: A Historic Preservation Plan for South Carolina (2007 - 2015)

State Planning: SC State Historic Preservation Office

(Downloadable PDF Copy at: www.scdah.sc.gov)

Technology and techniques for building rehabilitation, Historic Building Trade Catalogs:

Association for Preservation Technology International

3085 Stevenson Drive, Suite 200

Springfield, IL 62703

(217) 529-9039

www.apti.org

Specific info. for Southeast Chapter at:

www.apti.org/chapters/southeast/index.cfm

Education, networking, and outreach for the traditional building trades:

Preservation Trades Network, Inc.

PO Box 249

Amherst, New Hampshire 03031-0249

(866) 853-9335 (toll free)

<http://www.iptw.org>

Resources for commercial, civic, institutional, and religious building projects:

Traditional Building Magazine

45 Main Street, Ste 705

Brooklyn, New York 11201

(718) 636-0788

www.traditional-building.com

Documentation and conservation of buildings, sites and neighborhoods of the modern movement:

DOCOMOMO US

P.O. Box 230977

New York, NY 10023

National and US info at: www.docomomo-us.org

Visit Georgia Chapter at: www.docomomoga.org

Visit North Carolina Chapter at: www.newraleigh.com/articles/archive/docomomo-north-carolina-chapter/
(At time of printing South Carolina had no individual Chapter.)

National representation, technical support and information for preservation design review commissions:

National Alliance of Preservation Commissions:

225 West Broad Street

Athens, GA 30602

(706) 369-4731

www.uga.edu/napc

Statewide non-profit with the National Trust for preservation education, advocacy, funding & networking:

The Palmetto Trust for Historic Preservation

8301 Parklane Road

Columbia, SC 29223

(803) 896-6234

www.palmettotrust.org

