

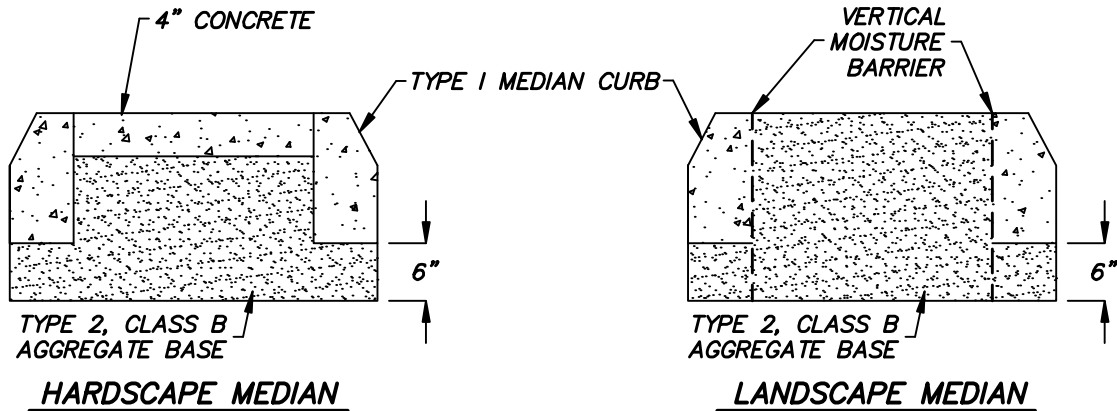

PAINTED PERMANENT YELLOW

DOUBLE SOLID YELLOW PERMANENT STRIPING AT BOTH APPROACHES

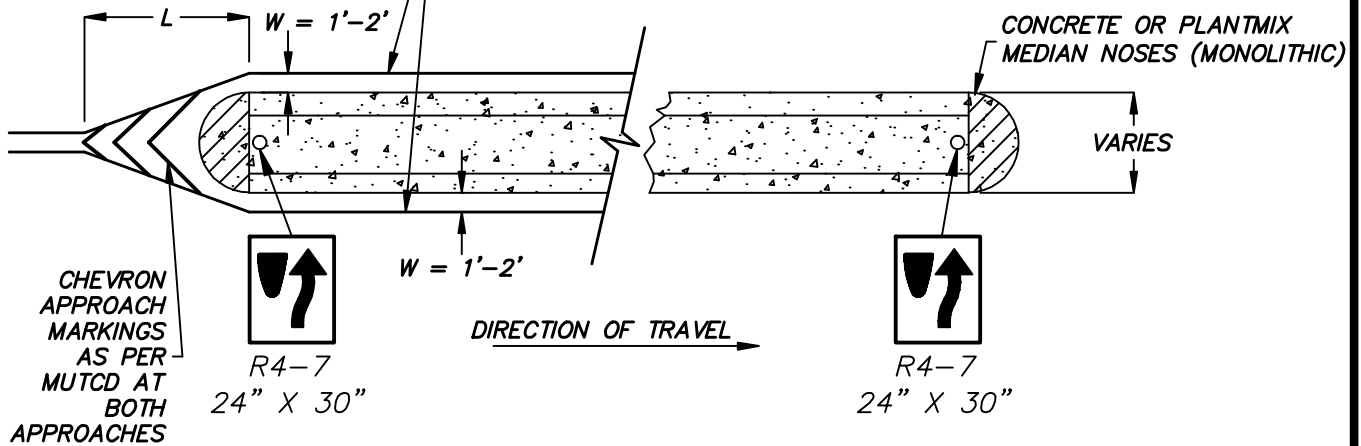

NOTES:

1. CONCRETE SHALL MEET THE REQUIREMENTS OF SECTION 337.10 OF THE LATEST EDITION OF THE STANDARD SPECIFICATIONS FOR PUBLIC WORKS CONSTRUCTION.
2. AGGREGATE BASE MATERIAL SHALL MEET THE REQUIREMENTS OF SECTION 302 & 308 OF THE LATEST EDITION OF THE STANDARD SPECIFICATIONS FOR PUBLIC WORKS CONSTRUCTION.
3. MEDIAN ISLAND SHALL NOT BE LOCATED WITHIN 20' OF ANY DRIVEWAY UNLESS OTHERWISE APPROVED.
4. LANDSCAPED MEDIAN ISLAND DESIGN PLANS SHALL REQUIRE APPROVAL BY THE CITY OF ELKO PRIOR TO INSTALLATION.
5. MEDIAN INSTALLATION SHALL MEET THE REQUIREMENTS OF THE LATEST EDITION OF THE M.U.T.C.D.
6. L EQUALS THE TAPER LENGTH (FT)
 - 45 MPH OR >: L = OFFSET WIDTH (W) X POSTED SPEED LIMIT
 - < 45 MPH: L = OFFSET WIDTH (W) X (POSTED SPEED LIMIT)² ÷ 60.
7. R4-7 SIGNS ARE OPTIONAL FOR COLLECTOR RESIDENTIAL OR LOCAL RESIDENTIAL STREETS AND ANY SMALLER STREETS.

NO.	REVISION	DATE	STANDARD DETAILS FOR PUBLIC WORKS CONSTRUCTION	SECTION
			MEDIAN ISLANDS	ROADWAY
				DRAWING NO.
				R-7.1
				DATE
				11/30/07
				PAGE
				1
CITY OF ELKO, NEVADA				